

VORON ZERO ASSEMBLY MANUAL

We build space shuttles with gardening tools
so anyone can have a space shuttle of their own.

VERSION 2024-05-07



Before you begin on your journey, a word of caution.

This machine can maim, burn, and electrocute you if you are not careful.

Please do not become the first VORON fatality.

There is no special Reddit flair for that.

Please, read the entire manual before you start assembly.

As you begin wrenching, please check our Discord channels for any tips and questions that may halt your progress.

Most of all, good luck!

The VORON Team

Introduction	04
Hardware	08
Extrusion Prep	12
Frame	17
A/B Drives	68
A/B Idlers	83
Z Axis	91

X Axis	114
A/B Belts	131
Print Bed	144
Print Head	156
Electronics & Wiring	190
Skirts & Panels	213
Tophat	235

PART PRINTING SETTINGS AND GUIDELINES

The Voron Team has provided the following print guidelines for you to follow in order to have the best chance at success with your parts. There are often questions about substituting materials or changing printing standards, but we recommend you follow these.

3D PRINTING PROCESS

Fused Deposition Modeling (FDM)

INFILL TYPE

Grid, Gyroid, Honeycomb, Triangle or Cubic

MATERIAL

ABS/ASA

INFILL PERCENTAGE

Recommended: 40%

LAYER HEIGHT

Recommended: 0.2mm

WALL COUNT

Recommended: 4

EXTRUSION WIDTH

Recommended: Forced 0.4mm

SOLID TOP/BOTTOM LAYERS

Recommended: 5

PRINT IT FORWARD (PIF)

Often times community members that have issues printing ABS will bootstrap themselves into a VORON using our Print It Forward program. This is a service where approved members with VORON printers can make you a functional set of parts to get your own machine up and running. Further Details about the PIF program can be found on the Discord server or by visiting <https://pif.voron.dev>.

FILE NAMING

By this time you should have already downloaded our STL files from the Voron GitHub. You might have noticed that we have used a unique naming convention for the files. This is how to use them.

PRIMARY COLOR

B_Drive_Frame_Lower_x1.stl

These files will have nothing at the start of the filename.

ACCENT COLOR 

[a]_Tensioner_Knob_x2.stl

We have added “[a]” to the front of any STL file that is intended to be printed with accent color. The parts are marked with a heart in the manual when they first appear.

CLEAR / TRANSLUCENT

[c]_Display_Diffuser_x1.stl

Any file that begins with [c] is intended to be printed in a clear or translucent color that allows light to penetrate through it.

QUANTITY REQUIRED

[a]_Thumb_Nut_x3.stl

Any file that ends with “_x#” is telling you the quantity of that part required to build the machine.

STL FILE LIST

We have put together a comprehensive list of all the STL files used in this manual you can use this to keep track of parts you have printed, identify the names of printed parts, and/or reference where they are used in the body of this manual. Simply copy the document from the link and you can markup a local copy for yourself: <https://voron.link/3p5kekz>.



<https://voron.link/3p5kekz>

HOW TO GET HELP

If you need assistance with your build, we're here to help. Head on over to our Discord group and post your questions. This is our primary medium to help VORON Users and we have a great community that can help you out if you get stuck.



<https://discord.gg/voron>



<https://forum.vorondesign.com>

REPORTING AN ISSUE

Should you find an issue in the documentation or have a suggestion for an improvement please consider opening an issue on GitHub (<https://github.com/VoronDesign/Voron-0/issues>). When raising an issue please include the relevant page numbers and a short description; annotated screenshots are also very welcome. We periodically update the manual based on the feedback we get.

THIS IS JUST A REFERENCE

This manual is designed to be a simple reference manual. Building a Voron can be a complex endeavour and for that reason we recommend downloading the CAD files off our Github repository if there are sections you need clarification on. It can sometimes be easier to follow along when you have the whole assembly in front of you.



<https://github.com/VoronDesign>



<https://docs.vorondesign.com>

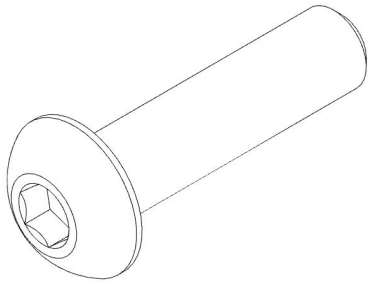

BUTTON HEAD CAP SCREW (BHCS)

Metric fastener with a domed shaped head and hex drive. Most commonly found in locations where M3 fasteners are used.

ISO 7380-1

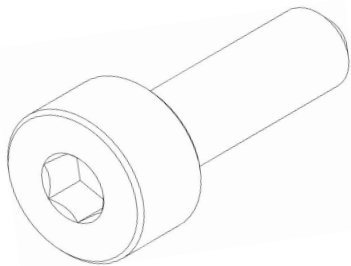

SOCKET HEAD CAP SCREW (SHCS)

Metric fastener with a cylindrical head and hex drive. The most common fastener used on the Voron.

ISO 4762 / DIN 912

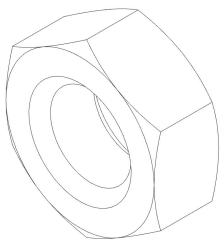

HEX NUT

Hex nuts couple with bolts to create a tight, secure joint. You'll see these used in both M2 and M3 variants throughout this guide.

ISO 4032 / DIN 934

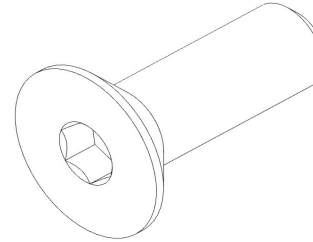

FLAT HEAD CAP SCREW (FHCS)

Metric fastener with a cone shaped head and a flat top.

ISO 10642

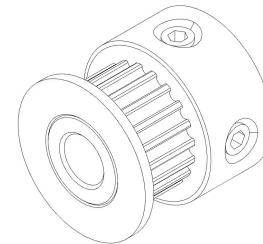

PULLEY

GT2 pulley used on the motion system of the Voron.

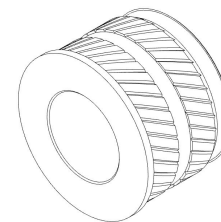

HEAT SET INSERT

Heat the inserts with a soldering iron so that they melt the plastic when installed. As the plastic cools, it solidifies around the knurls and ridges on the insert for excellent resistance to both torque and pull-out.

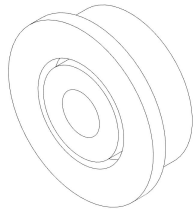

F623 BEARING

A ball bearing with a flange used in various gantry locations.

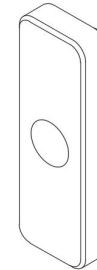

MAKERBEAM T-NUT

This is a special, longer, T-nut that is only used in the toolhead for securing the belts.

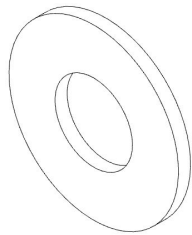

M3 SHIMS

Not to be confused with stamped washers. These are used in all M3 call-out locations in this manual.



ATTENTION BUBBLE

This logo denotes steps that are common areas that mistakes can occur.

3x6x0.5 DIN 988

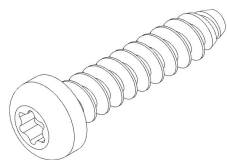

SELF TAPPING SCREW

Fastener with a pronounced thread profile that is screwed directly into plastic.



VORON HEART

Look for Voron heart next to the part. It indicates that this is a part that is usually printed in the accent color.

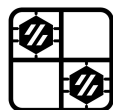

KIT CARD

Kit providers often include part options that are not standard design spec. We've added notes for popular ones marked with this icon.

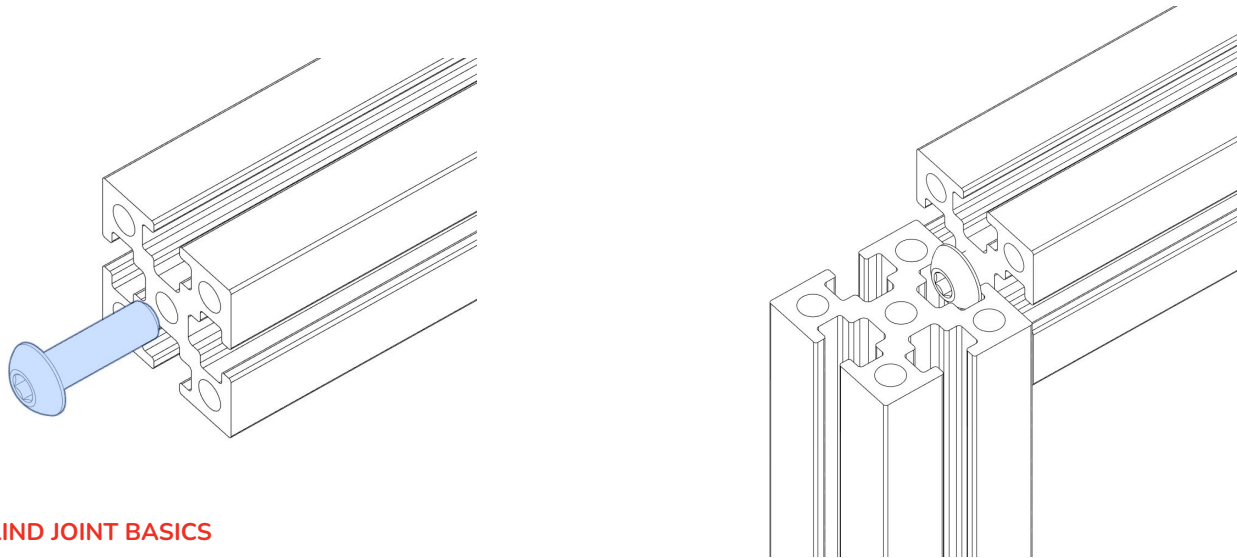

BLIND JOINT BASICS

Blind Joints provide a cost-effective and rigid assembly method.

The head of the BHCS is slid into the channel of another extrusion and securely fastened through a small access hole in the extrusion.

If you've never assembled one before we recommend you watch the linked guide.

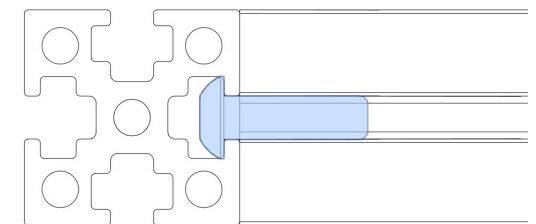
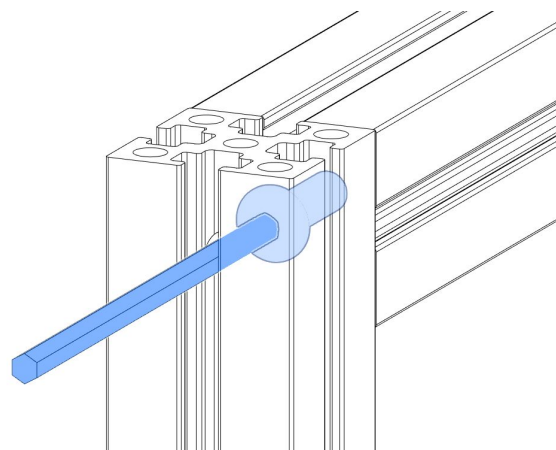

<https://voron.link/onjwmcd>

BALL-END DRIVER

Some parts of this design require the use of a ball-end hex driver for assembly. We recommend you get 1.5mm, 2mm and 2.5mm sizes.

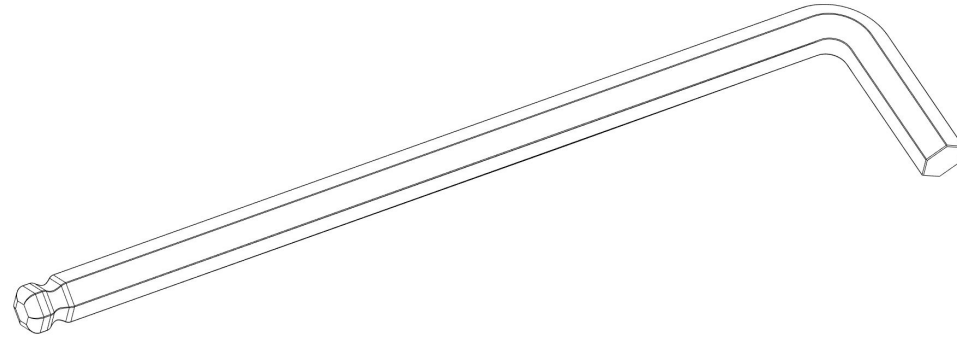
**2mm HEX DRIVER**

The 2mm hex driver will see a lot of use in this build. A quality driver is strongly recommended. Refer to the sourcing guide for suggestions.

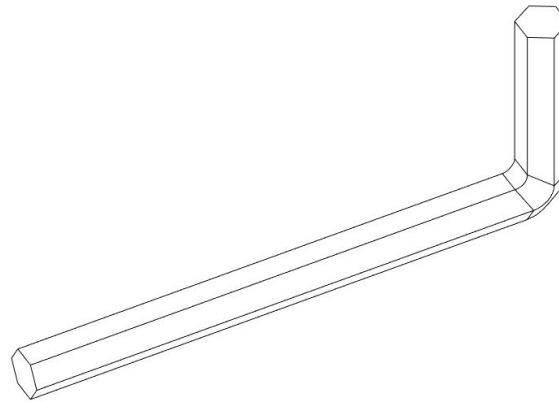
**ADDITIONAL TOOLS**

We provide additional tool recommendations in our sourcing guide. Visit https://vorondesign.com/sourcing_guide and switch to the "Voron Tools" tab at the bottom of the page.

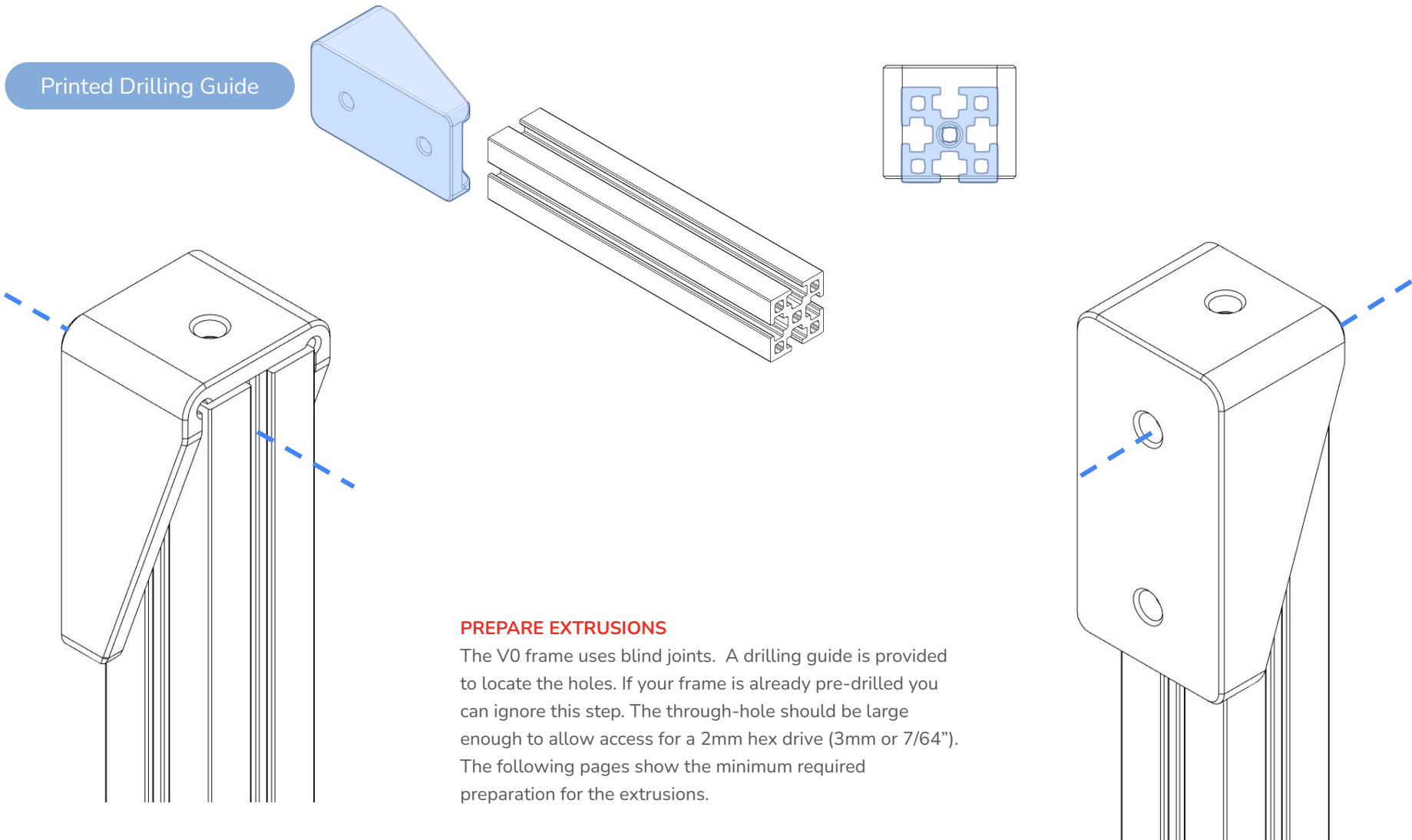

"A EXTRUSION"

Qty 1

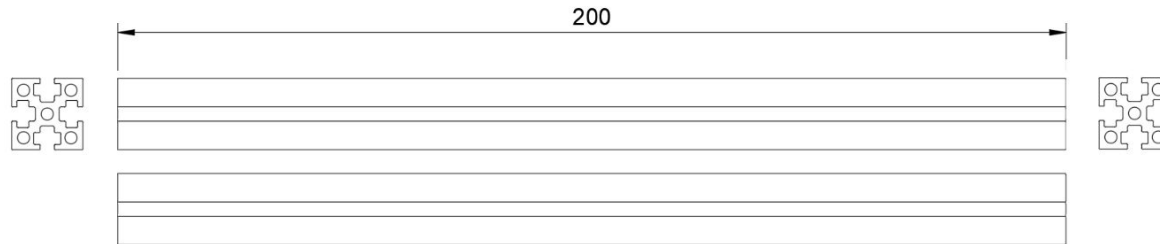

"B EXTRUSION"

Qty 5 (frame)

Qty 4 (tophat pg.236)

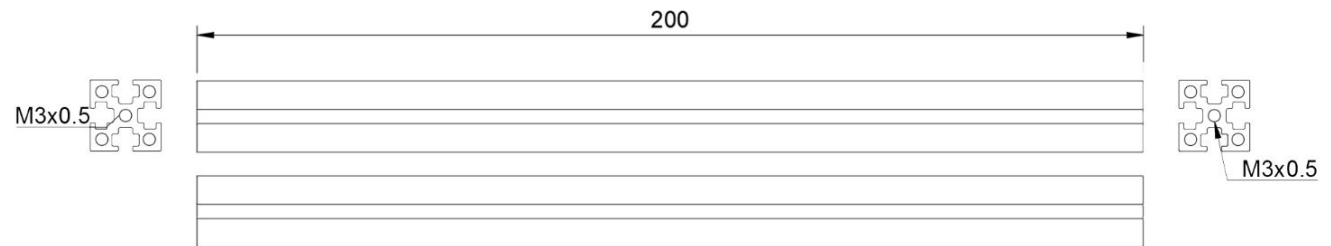

"C EXTRUSION"

Qty 2

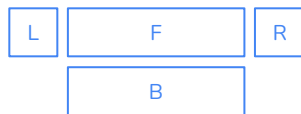
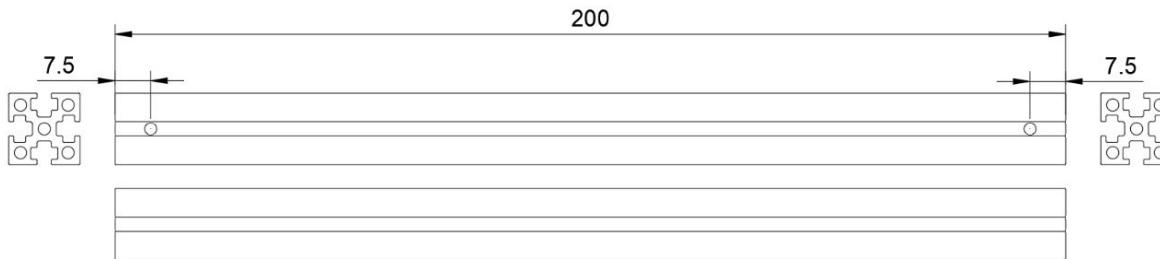

MULTIPLE VIEWS

The views shown are the left, front, right, and bottom views of each extrusion.

ORGANIZATION IS KEY

Quantity 4 of the "B" extrusions and quantity 4 of the "J" extrusions are designated for the tophat assembly which begins on page 236.

"D EXTRUSION"

Qty 2

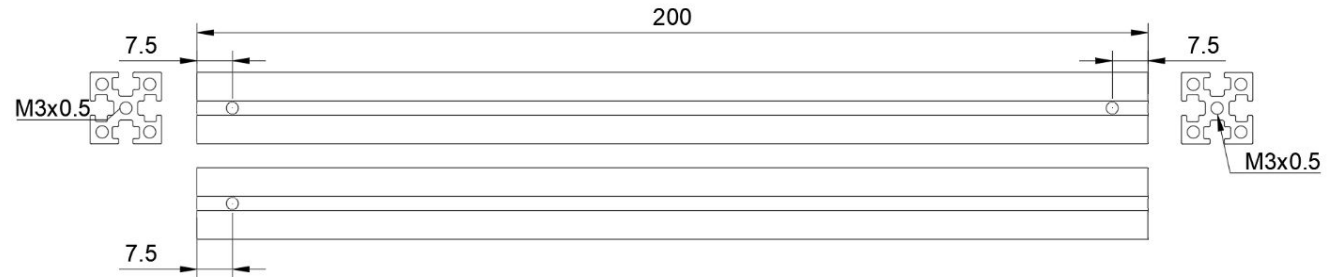

"E EXTRUSION"

Qty 4

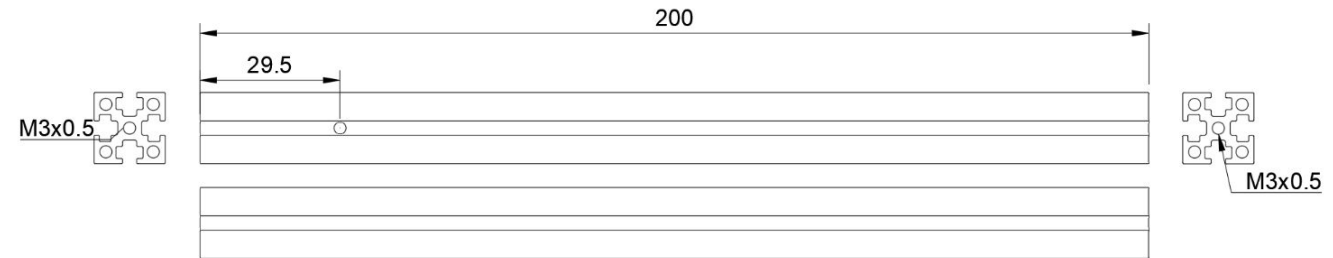

"F EXTRUSION"

Qty 2

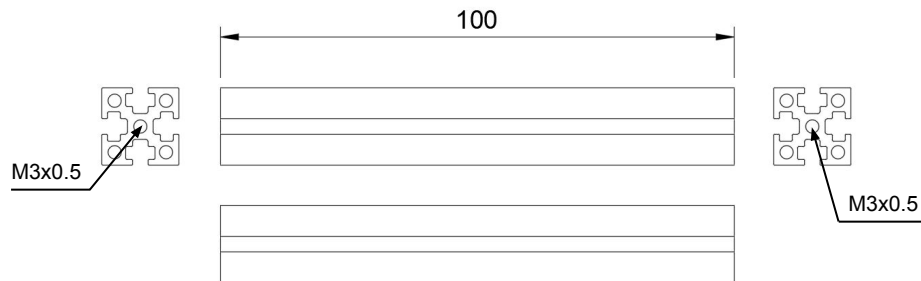

QTY:2.....BUT I HAVE 4!?

These pages cover the main extrusions used in the frame assembly. There are additional extrusion callouts on page 236 that are used in the extrusion tophat assembly.

THE ANCIENT ART OF KIRIGAMI

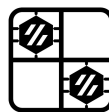

If you have the Kirigami bed kit, you do not need "G" or "F" extrusions. They will be replaced by the bent sheet metal component.

"G EXTRUSION"

Qty 1

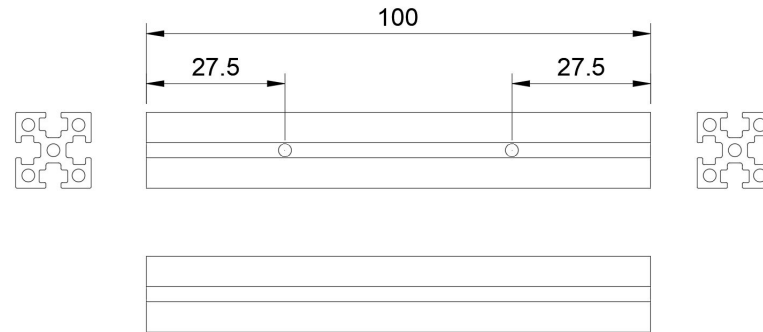

I'M MISSING EXTRUSIONS!?

If you purchased a kit you may not have un-drilled "F" extrusions or un-tapped "A" extrusions. This is ok; these pages denote the minimum requirements for the extrusions.

"H EXTRUSION"

Qty 2

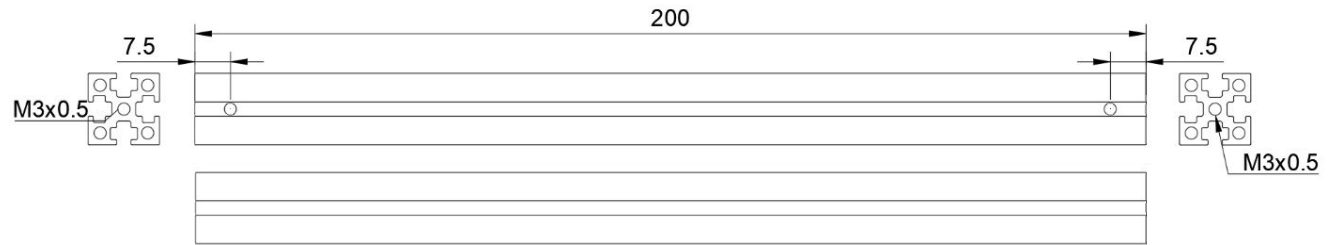

"J EXTRUSION"

Qty 4

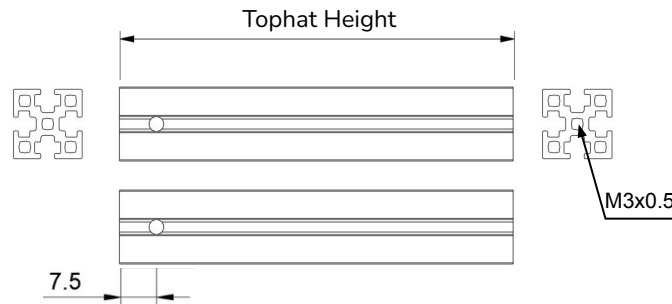

EXTRUSION CALL-OUTS

To avoid confusion we will call out the extrusions by the names shown on these reference pages.

H..I..J

We have intentionally skipped the "I" extrusion to avoid confusion with 1, l, and I.

ALL UNITS ARE METRIC

If a unit is not specified assume it's metric.

To help assembly along you may want to label the extrusions or print the reference page for a faster lookup.

VORON Zero

WWW.VORONDESIGN.COM

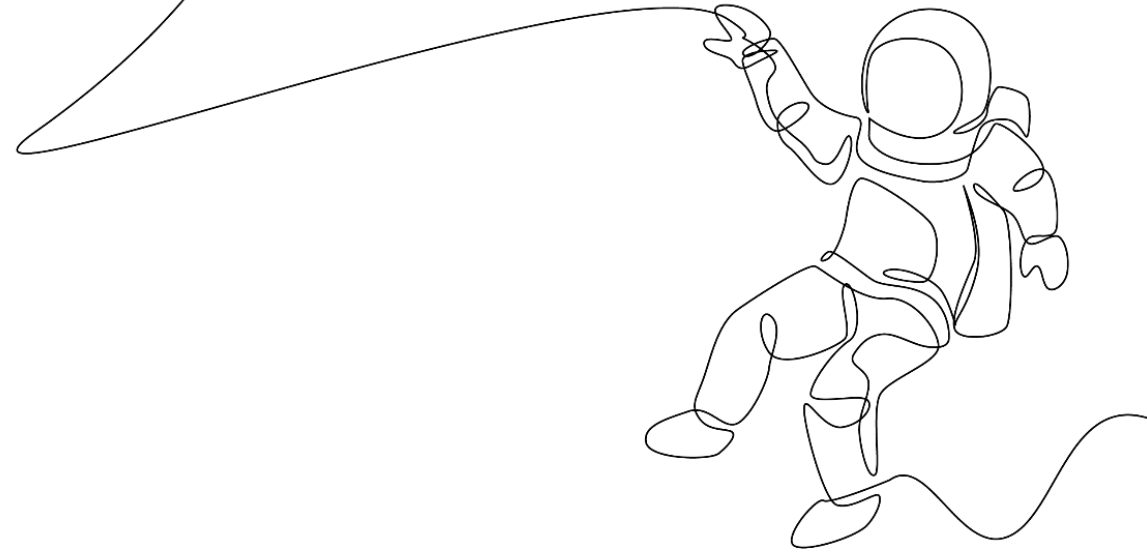

Grab your gardening tools.
We're about to blast off!

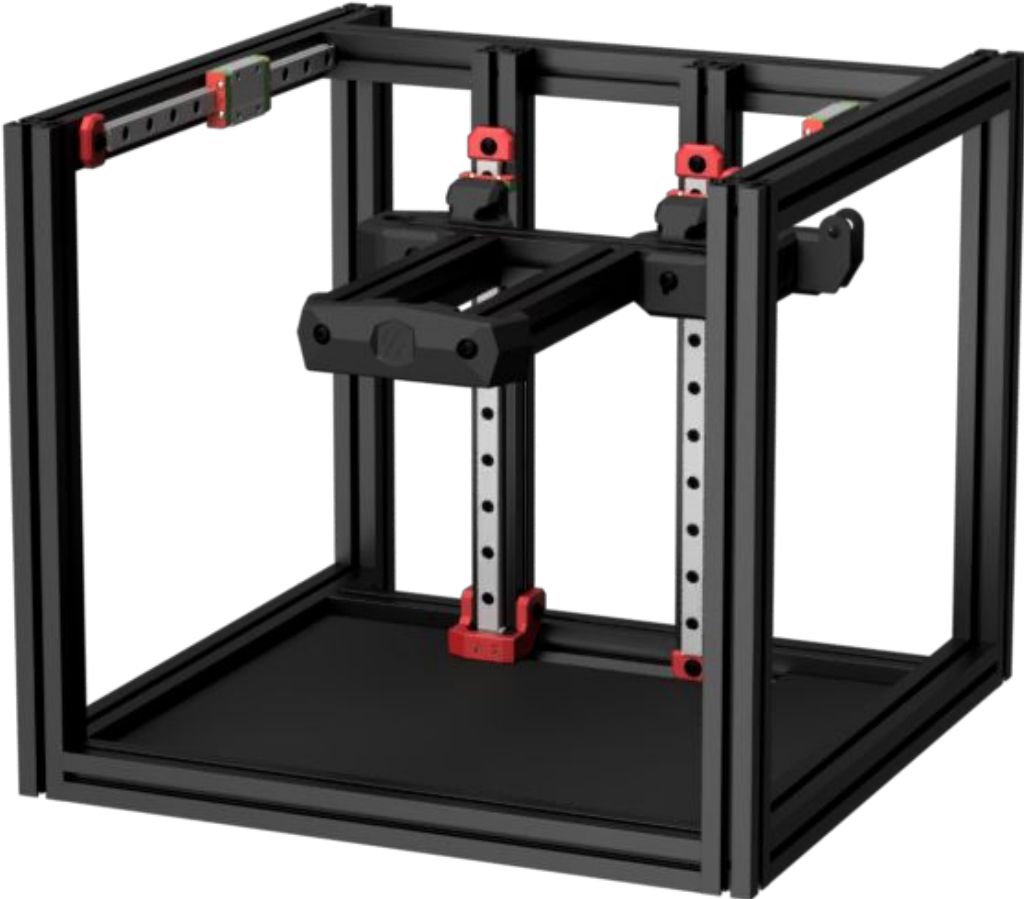

M2 Hex Nut

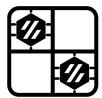
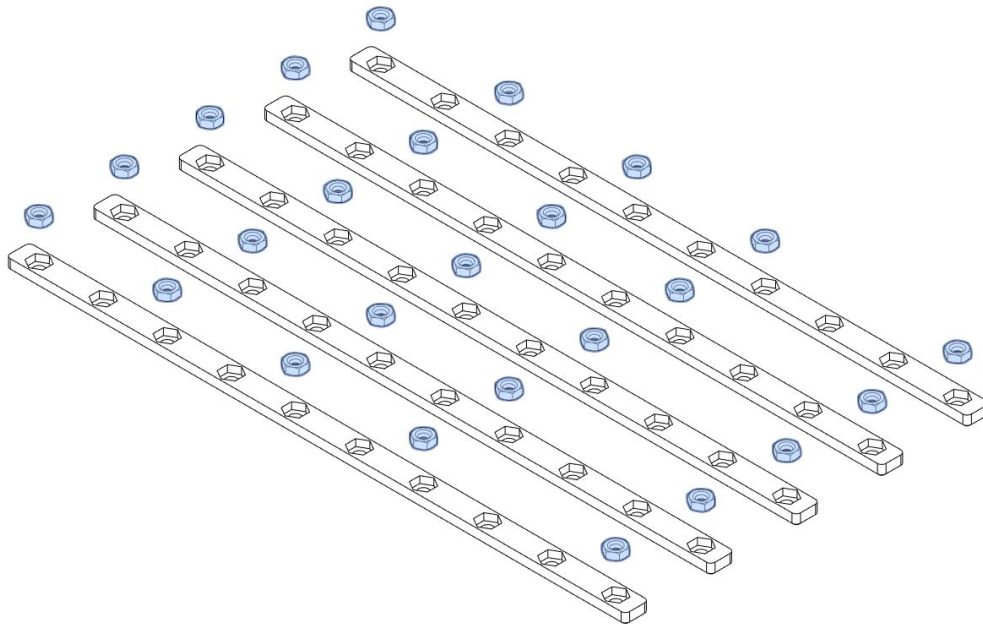

NUT BARS

Many kits come with metal bars with tapped M2 holes that replace these printed components.

POPULATING NUT CARRIERS

Depending on how much M2 hardware you sourced, you may not be able to fully populate the M2 Nut Adapters.

To fully populate all 5 adapters you need 50 M2x6 screws and M2 nuts.

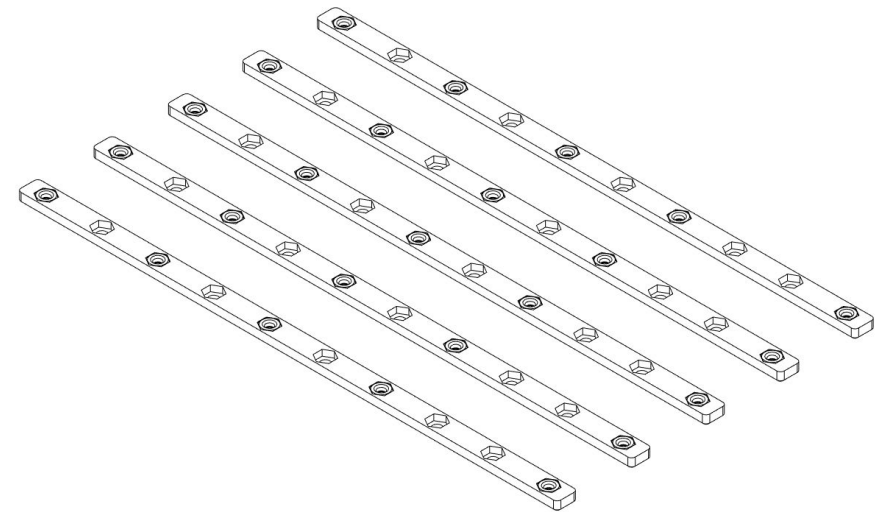

LINEAR RAILS - PREPARATION AND MOUNTING

Most linear rails arrive with shipping oil. To ensure a smooth gliding motion and long service life, this oil needs to be removed and its rail carriage greased. See the Voron sourcing guide for a recommended list of lubricants. We attached a link to a video guide to get you started. All 5 linear rails require the same lubrication prep.



<https://voron.link/agu0nes>

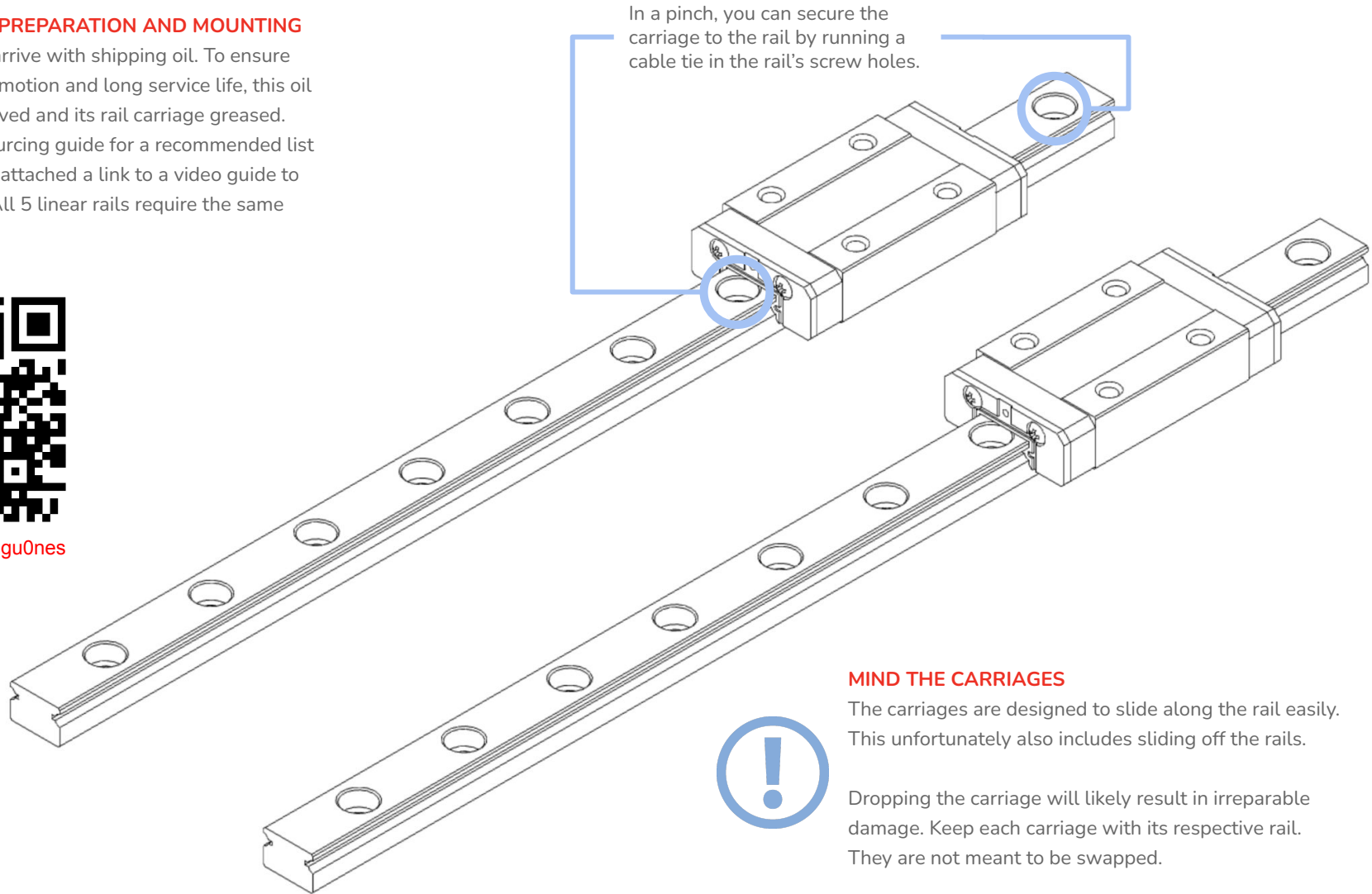

MIND THE CARRIAGES

The carriages are designed to slide along the rail easily. This unfortunately also includes sliding off the rails.

Dropping the carriage will likely result in irreparable damage. Keep each carriage with its respective rail. They are not meant to be swapped.

E Extrusions

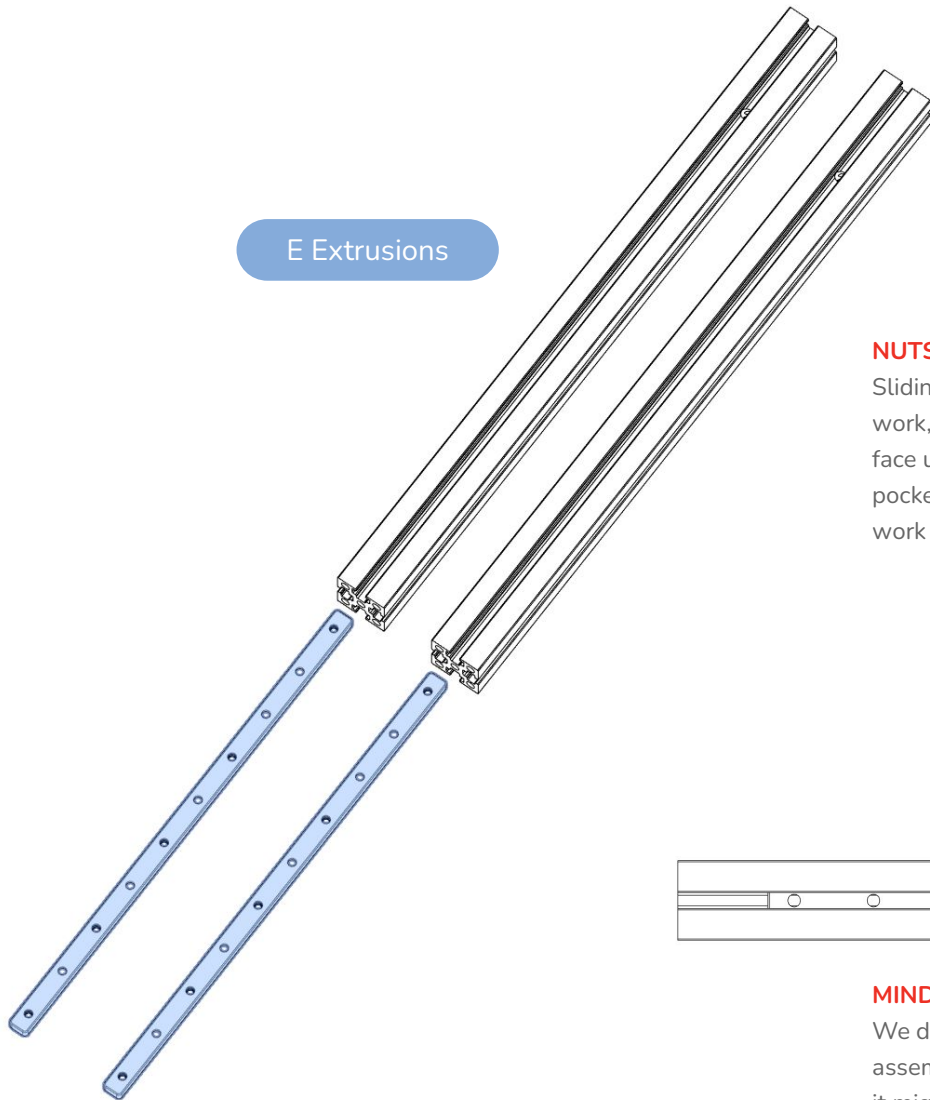

NUTS DOWN, NUTS UP?

Sliding the nut bars in face up or face down? Both options will work, some extrusion profiles (like LDO) work better with them face up as the nuts are less likely to pop out of their printed pockets when installing the screws. But both orientations work just fine.

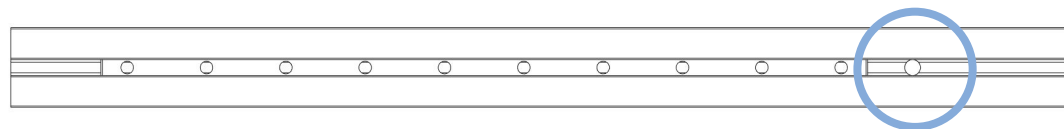

MIND THE ACCESS HOLE LOCATION

We do our best to call out things that may bite you later in the assembly process. If in doubt please refer to the CAD model, it might save you some considerable time down the road.

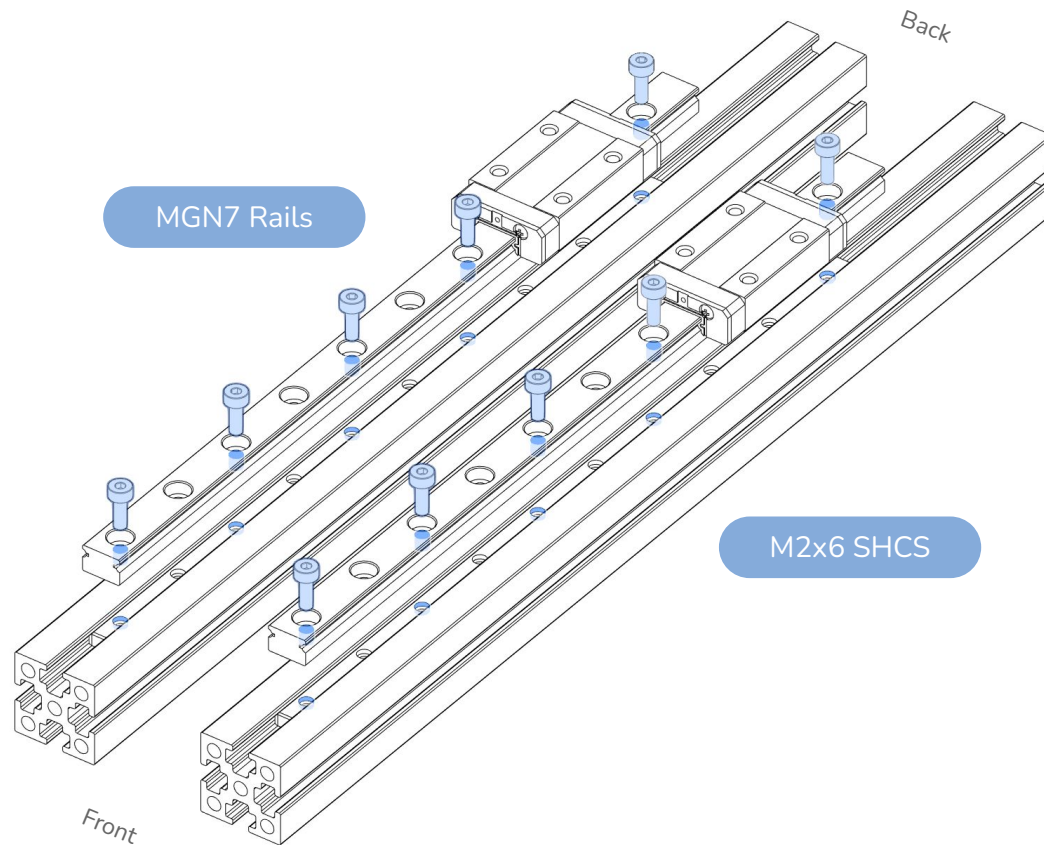

MOUNTING LINEAR RAILS

We opted to skip every other mounting hole in the linear rail when designing the mounting pattern for this printer. This cuts down on mounting hardware and still meets the requirements for our use case.

When tightening the bolts, tighten them from the center outward to ensure that the rail sits flush on the extrusion.

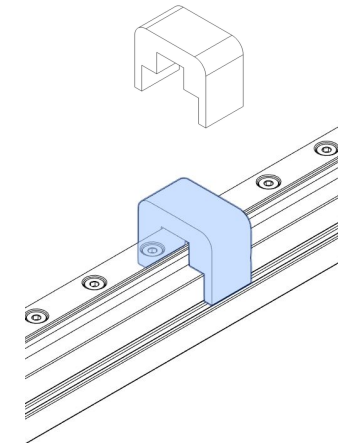
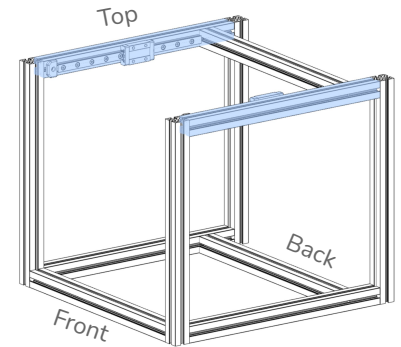

RAIL INSTALLATION GUIDES

Use the guides to position the rail in the center of the extrusion prior to fastening the screws.

PREVENTING MISHAPS

During assembly some rail ends won't be supported by stoppers that prevent the carriage from coming off the rails. Some rails come with little plastic stop pins, which you can leave in place.

If your rail does not have these stop pins, leave the last screws slightly loose to act as a stopper.

Alternatively use some tape to fix the carriage in place.

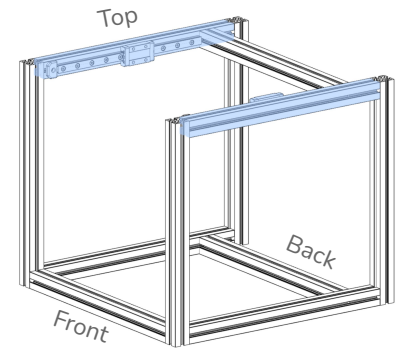
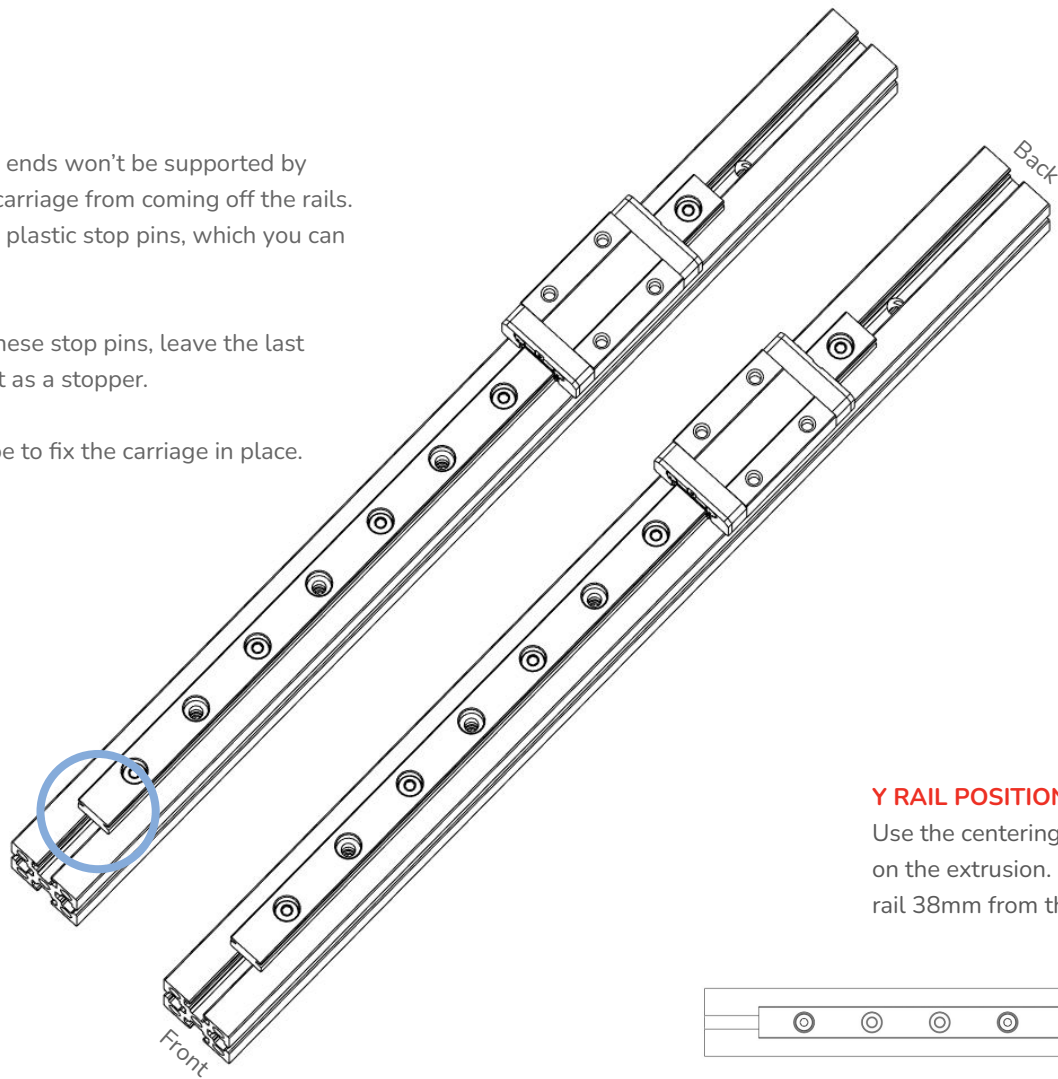

Y RAIL POSITIONING

Use the centering guides to align the rails on the extrusion. Position the end of the rail 38mm from the extrusion edge.

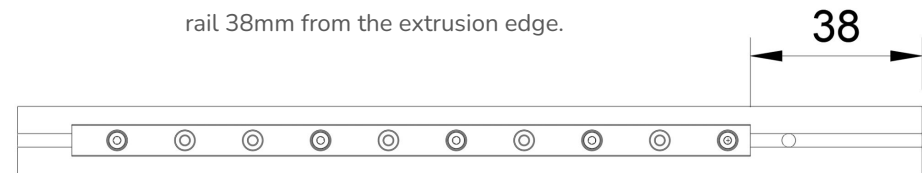

WHERE'S THE NUT!?

The instructions won't call out nuts that were inserted in a previous step, nor nuts that can be easily inserted in the current step. If a screw does NOT thread into a nut we will explicitly state this. **You can assume that all screws that enter extrusion slots thread into a nut.**



M3x8 BHCS

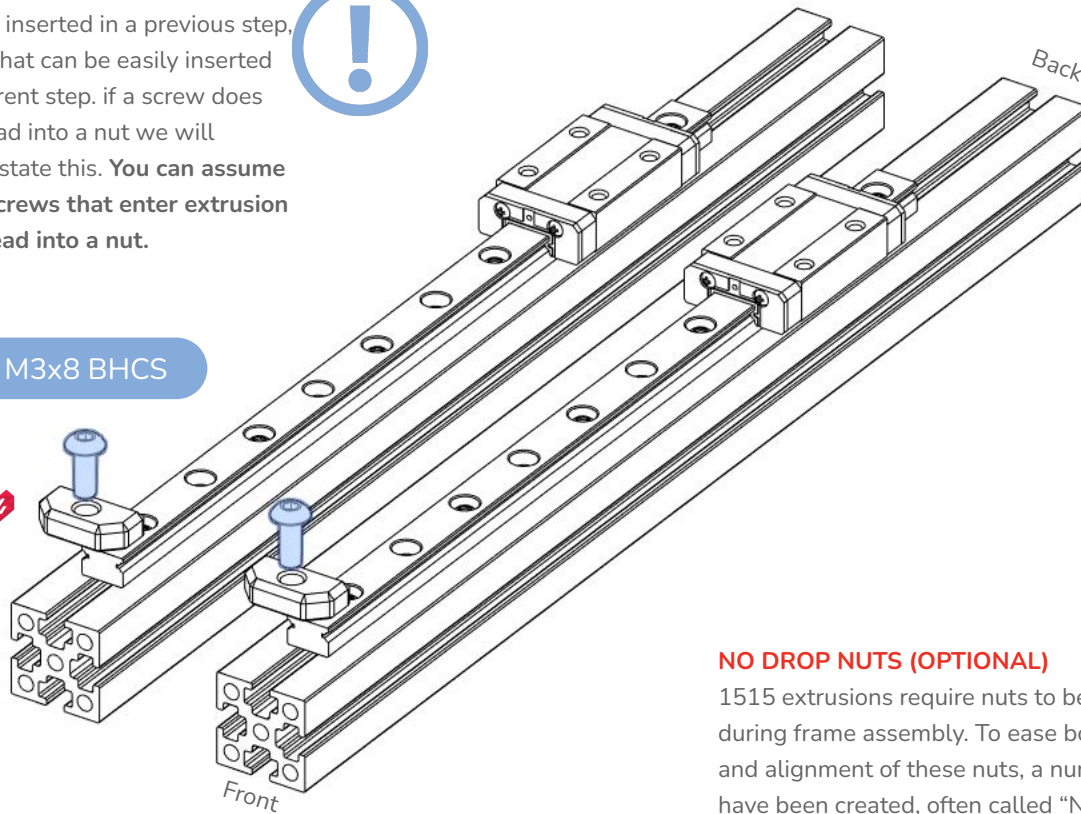

SQUARES OR HEXES?

Hex nuts and square nuts in the extrusion slots are interchangeable throughout the assembly. Use whichever you like!

NO DROP NUTS (OPTIONAL)

1515 extrusions require nuts to be preloaded during frame assembly. To ease both installation and alignment of these nuts, a number of usermods have been created, often called "No Drop Nuts". They can be found in the usermods github repo. They can be used almost anywhere preloaded nuts are needed. Their compatibility with voron design is not maintained by the development team. They may not work in all locations. For linear rails, use the long printed nut traps.

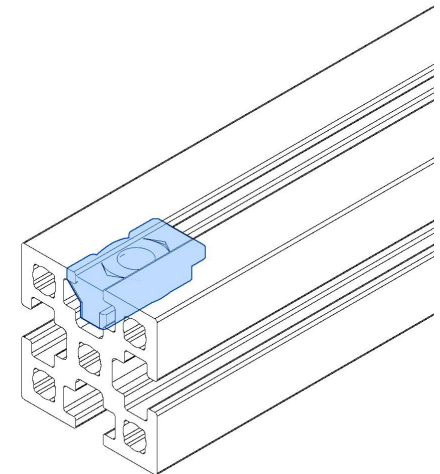
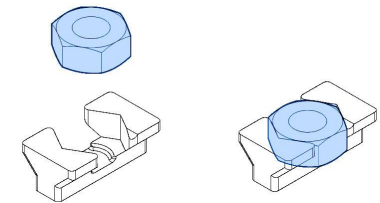
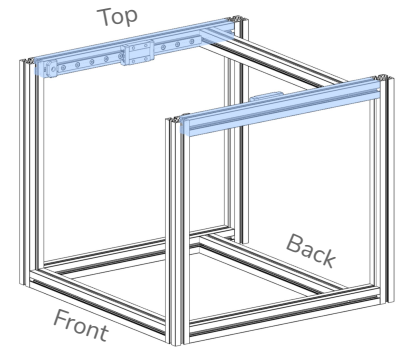

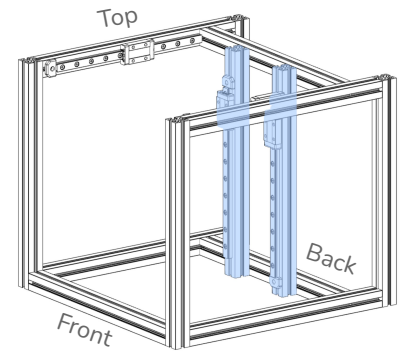
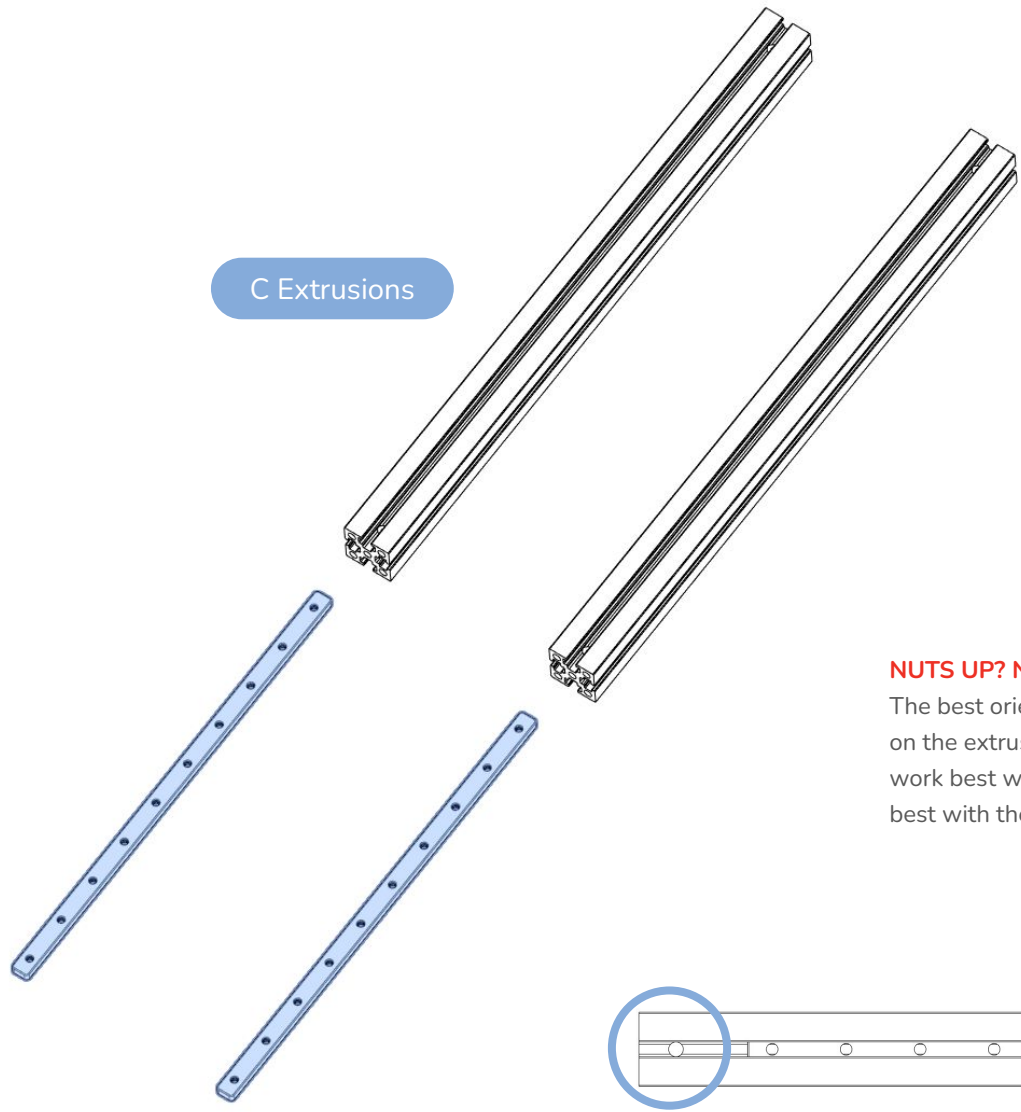

NUTS UP? NUTS DOWN?

The best orientation for your nut bars will depend on the extrusion profile you have, LDO extrusions work best with nuts facing up, makerbeams work best with them facing down.

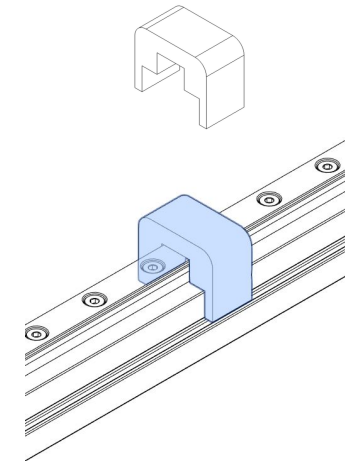
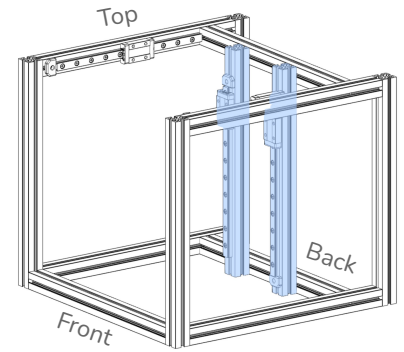
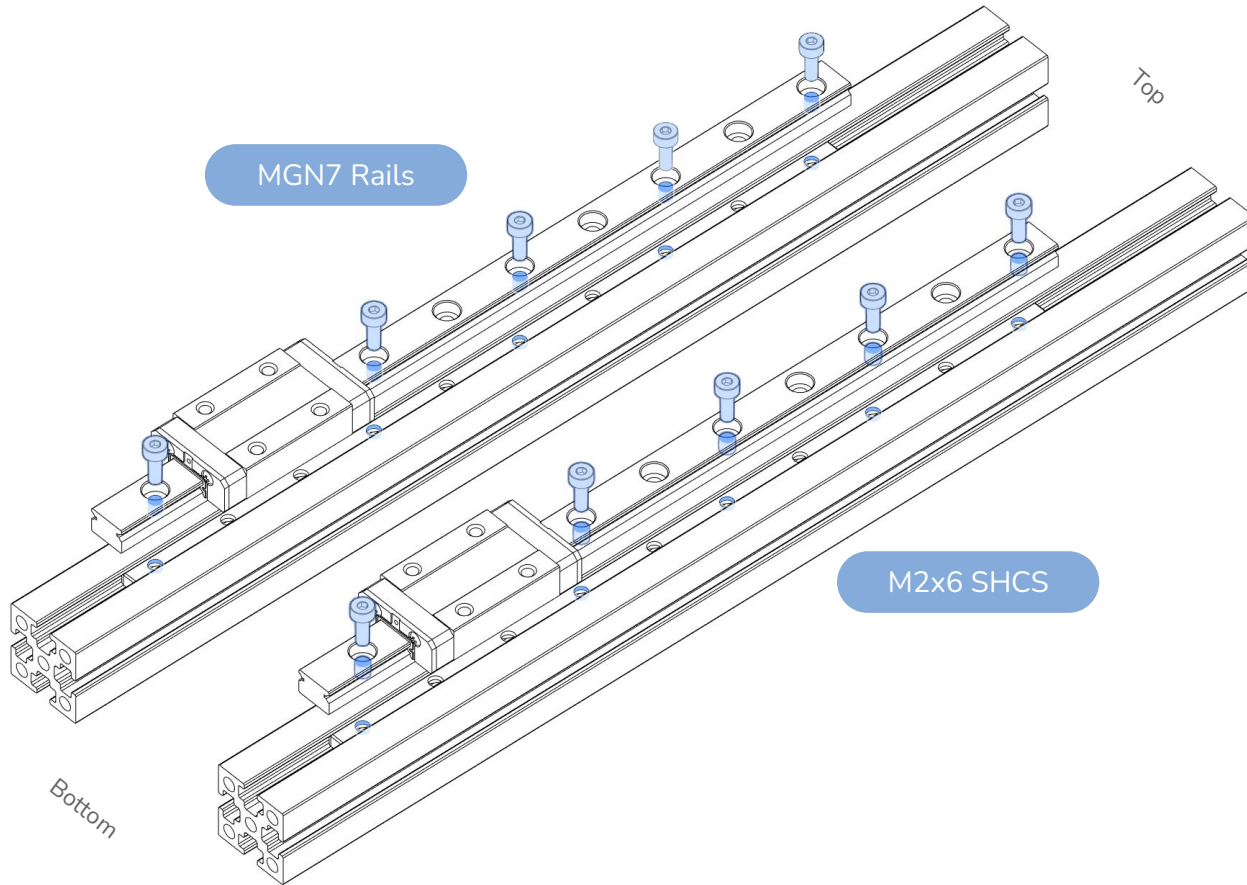

RAIL INSTALLATION GUIDES

Use the guides to position the rail in the center of the extrusion prior to fastening the screws.

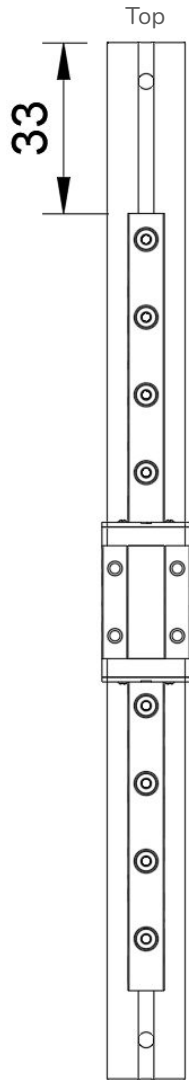

Z RAIL POSITIONING

Position the end of the rail about 33mm from the extrusion edge. This dimension may have to be adjusted later. Everyone's bed assembly will be slightly different heights.

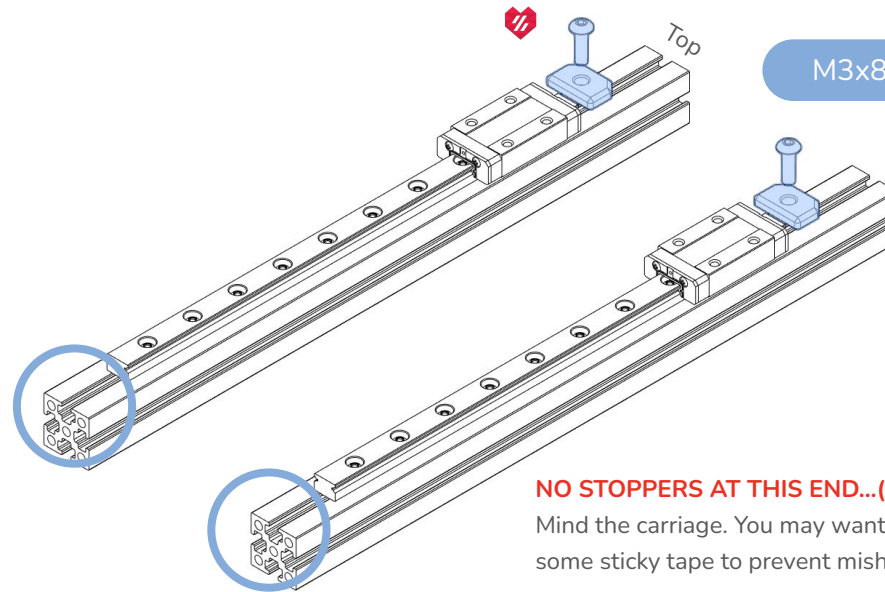
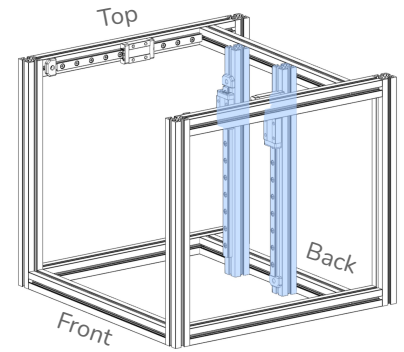
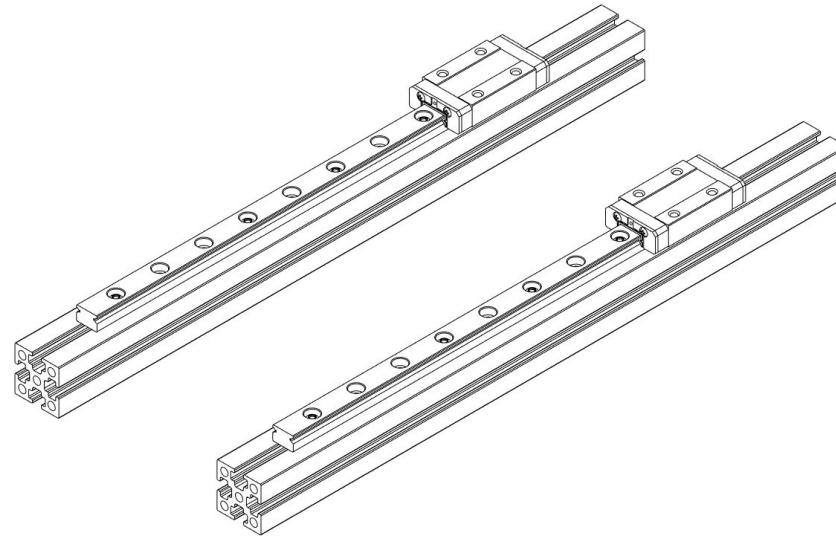

NO STOPPERS AT THIS END...(YET)
Mind the carriage. You may want to use some sticky tape to prevent mishaps.

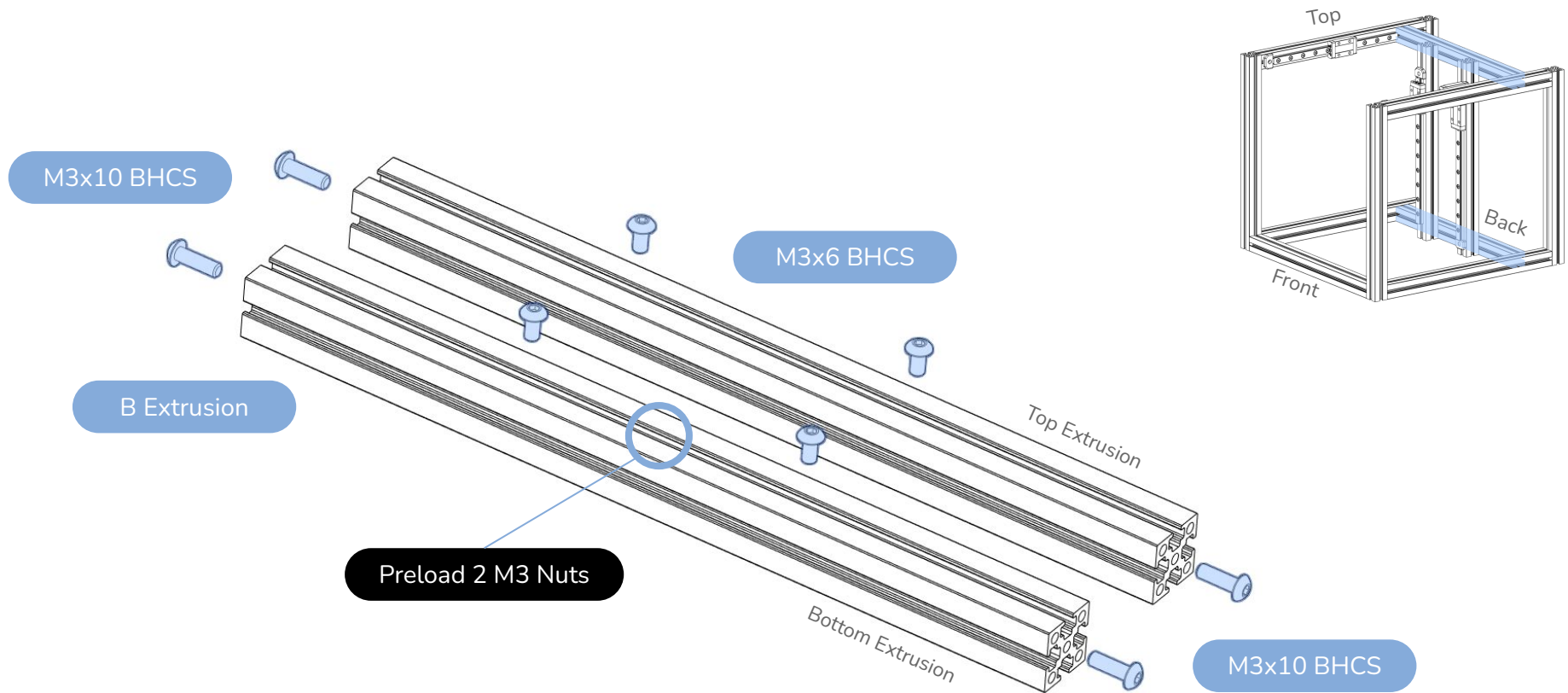

PRELOADING M3 NUTS

Insert 2 additional M3 nuts into the highlighted slot between the ones added to affix the M3x6. They will be used to attach the Z stepper mount in a later step.

Preloading will be a common theme going forward as you continue the build, PAY ATTENTION to the preload callouts. These preload callouts refer to EXTRA nuts in addition to the ones needed for the screws in each step.

ORIENTATION AND ASSEMBLY

Read the next 4 pages before continuing.

To keep the assembly images consistent and as easy to follow as possible, we are showing them in an upright orientation.

For ease of assembly, we recommend assembling the Z axis lying flat.

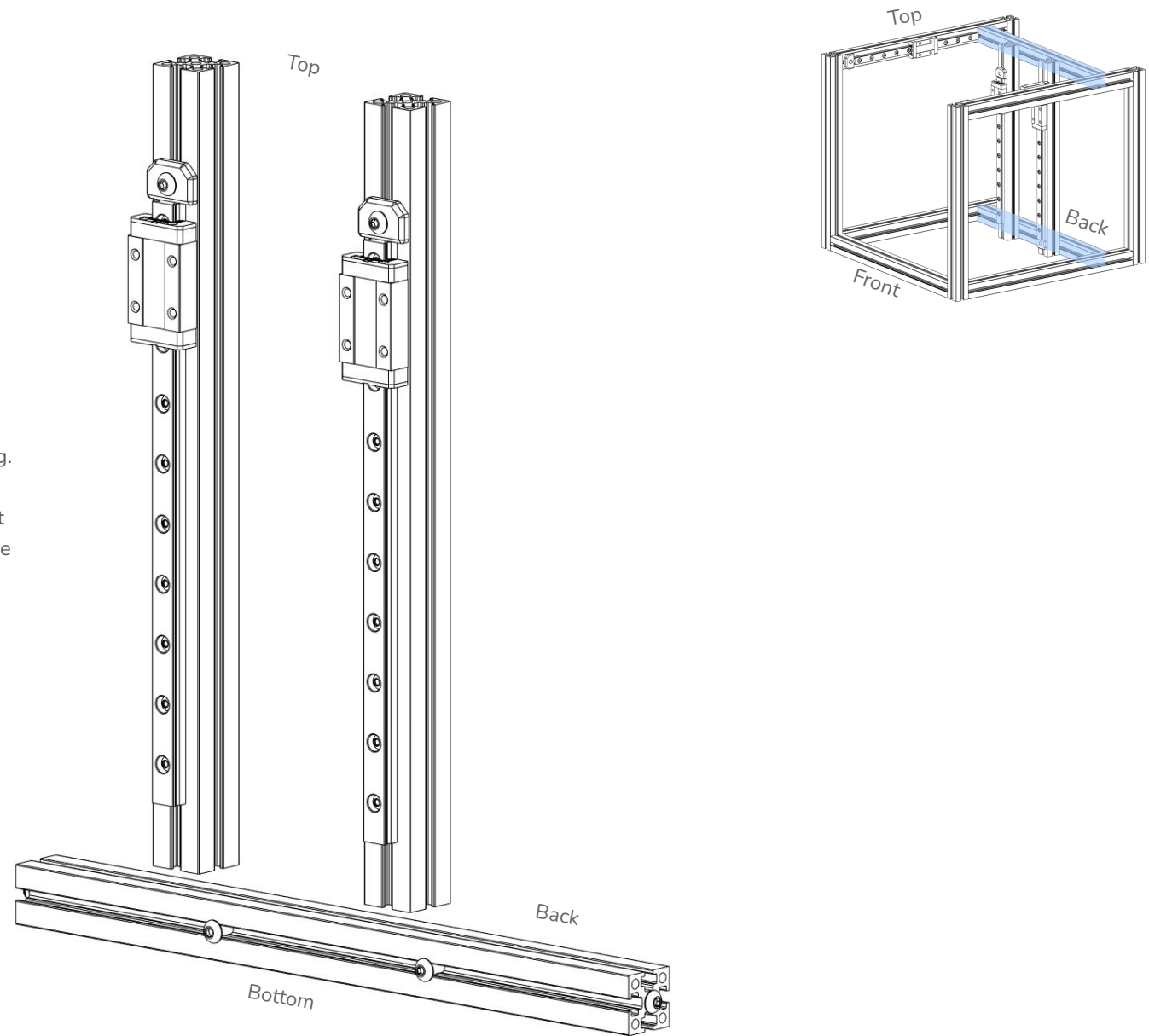

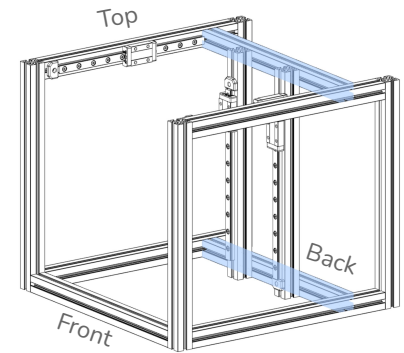
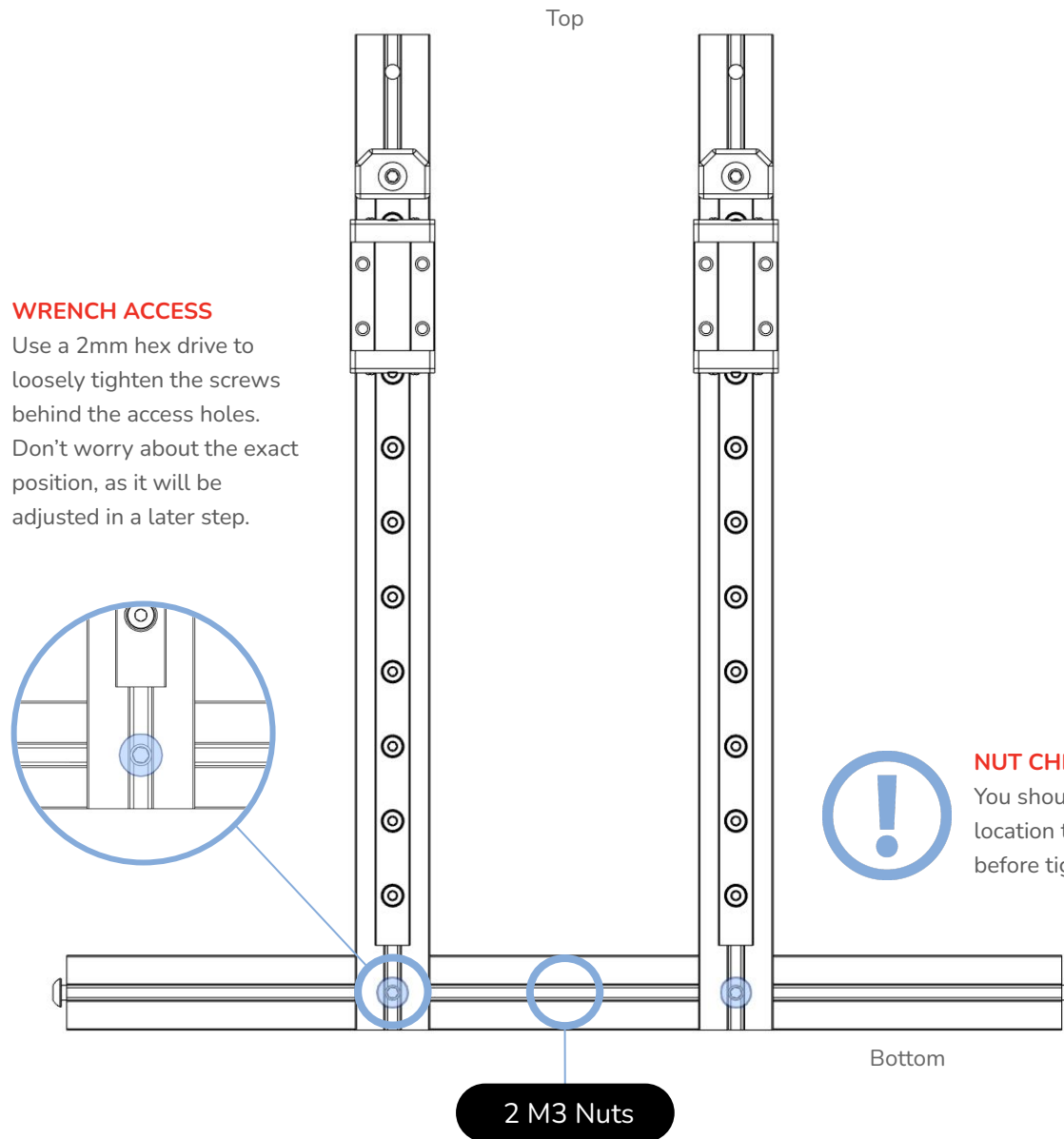

***DIRECT DRIVE VS. BOWDEN**

If you are planning on running a bowden setup, preload an additional 2 for a total of 5 M3 nuts into the marked position. These can be used to mount the bowden extruder.

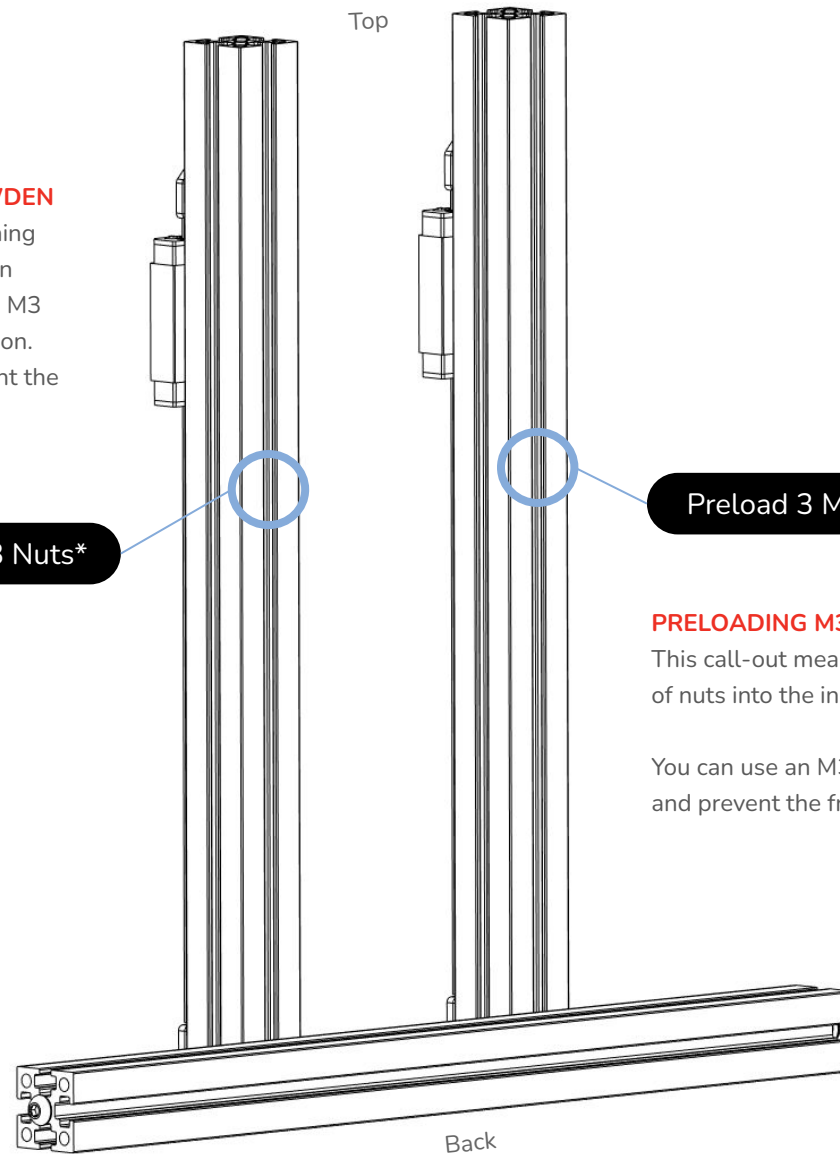

Preload 3 M3 Nuts

PRELOADING M3 NUTS

This call-out means you need to add the specified number of nuts into the indicated slot/position at this step.

You can use an M3 fastener to temporarily fix them in place and prevent them from sliding out of the slot.

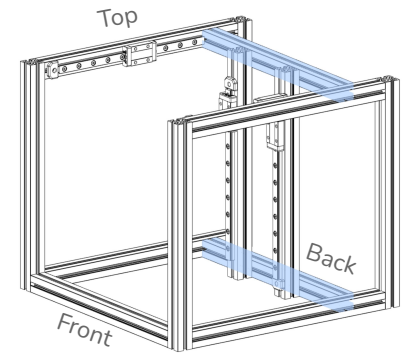

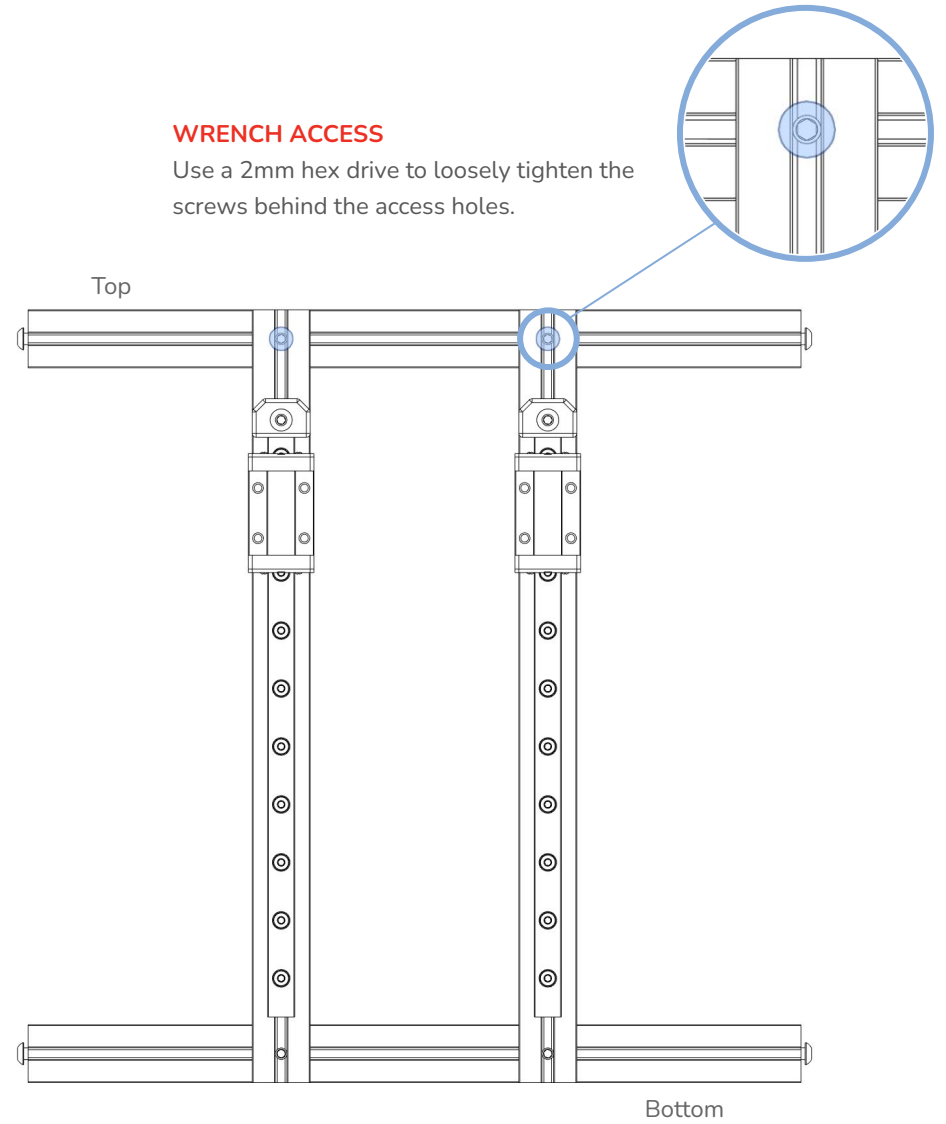
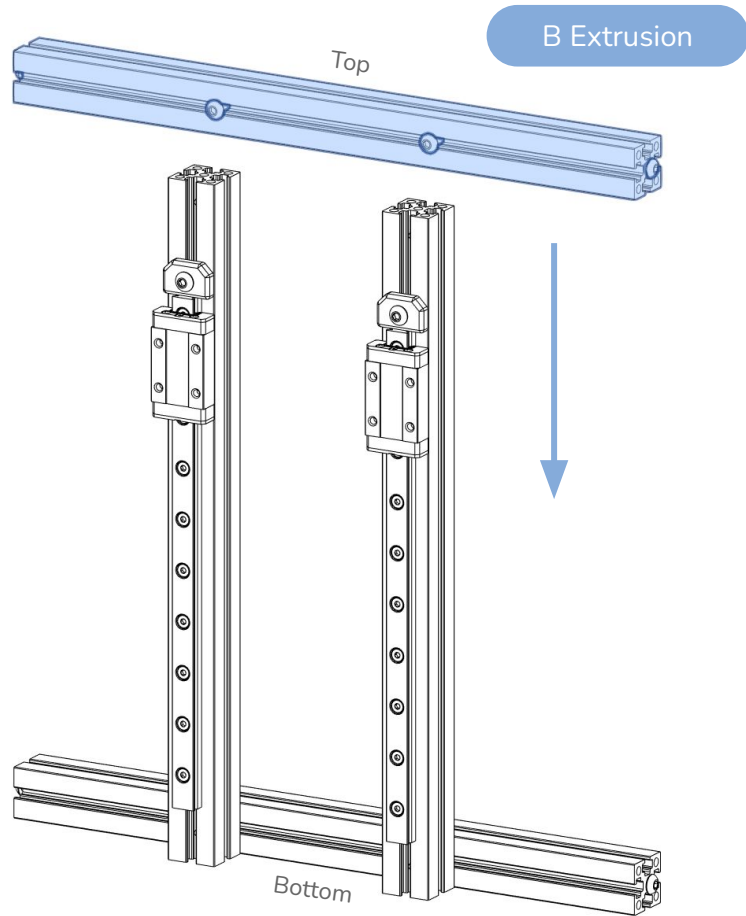

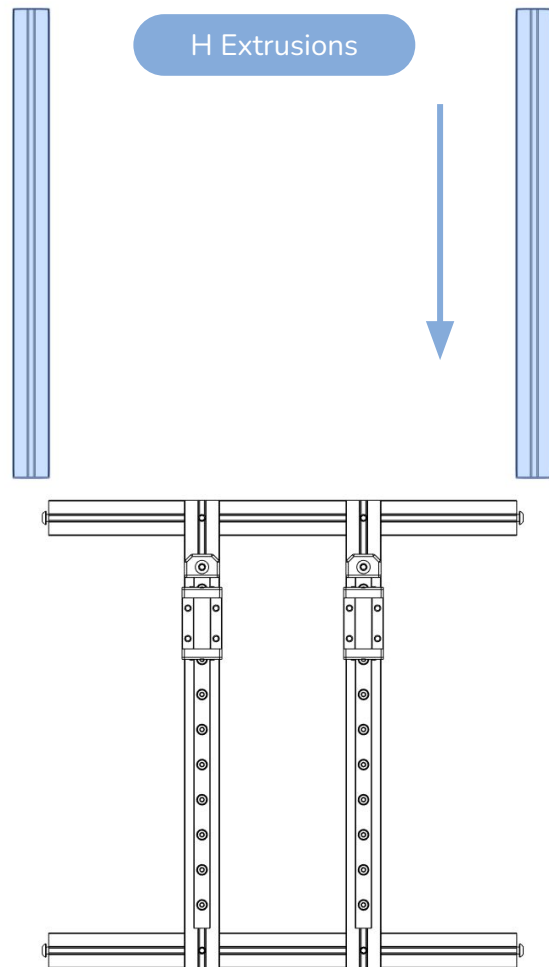

WHERE'S THE POSITION HELPER IMAGE?

These two extrusions are not part of the final frame assembly but using them temporarily will help us build a square and accurate bed assembly.

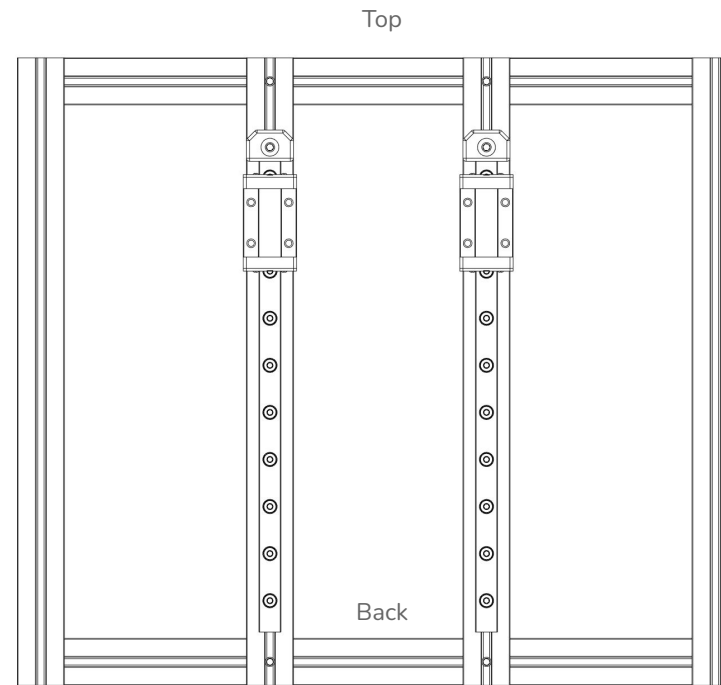

BUILD ON A FLAT SURFACE

Assemble the square on a glass or granite surface to ensure you can get it as square as possible. Tighten the screws in the left extrusion first.

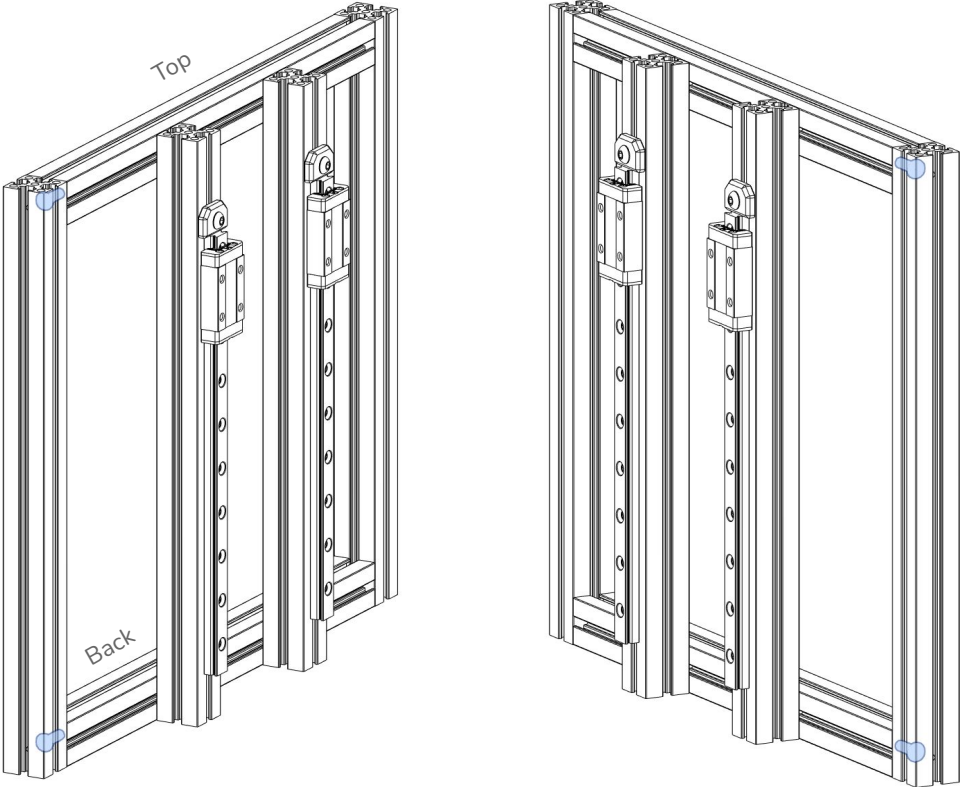

WRENCH ACCESS

Use a 2mm hex drive to tighten the screws behind the access holes.

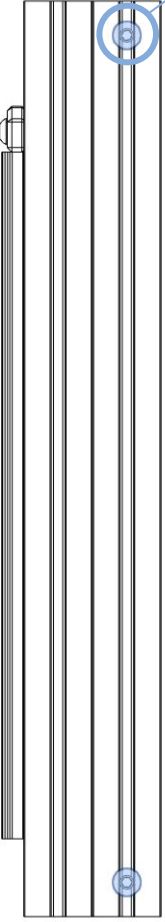
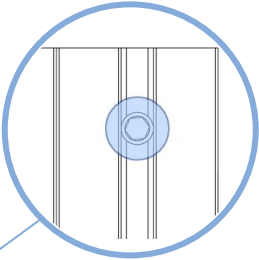

RIGHT

ADJUST POSITIONING

Adjust the position of the Z rails to roughly match the dimensions shown on the right. We will finalize this spacing in the next few steps; it is not a critical dimension at this point.

Ensure that the extrusions are parallel to each other as this will help when tramming the Z axis.

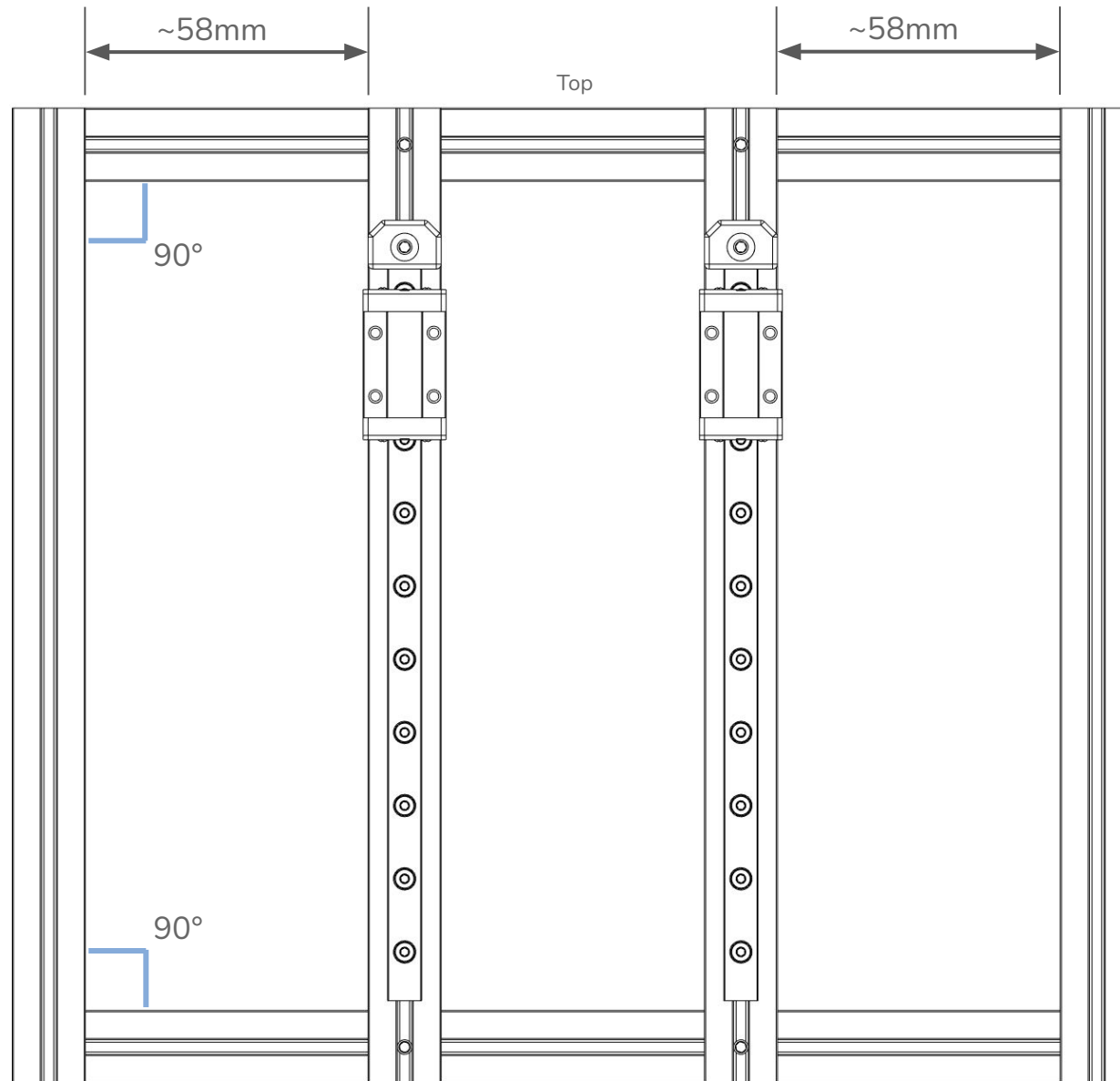

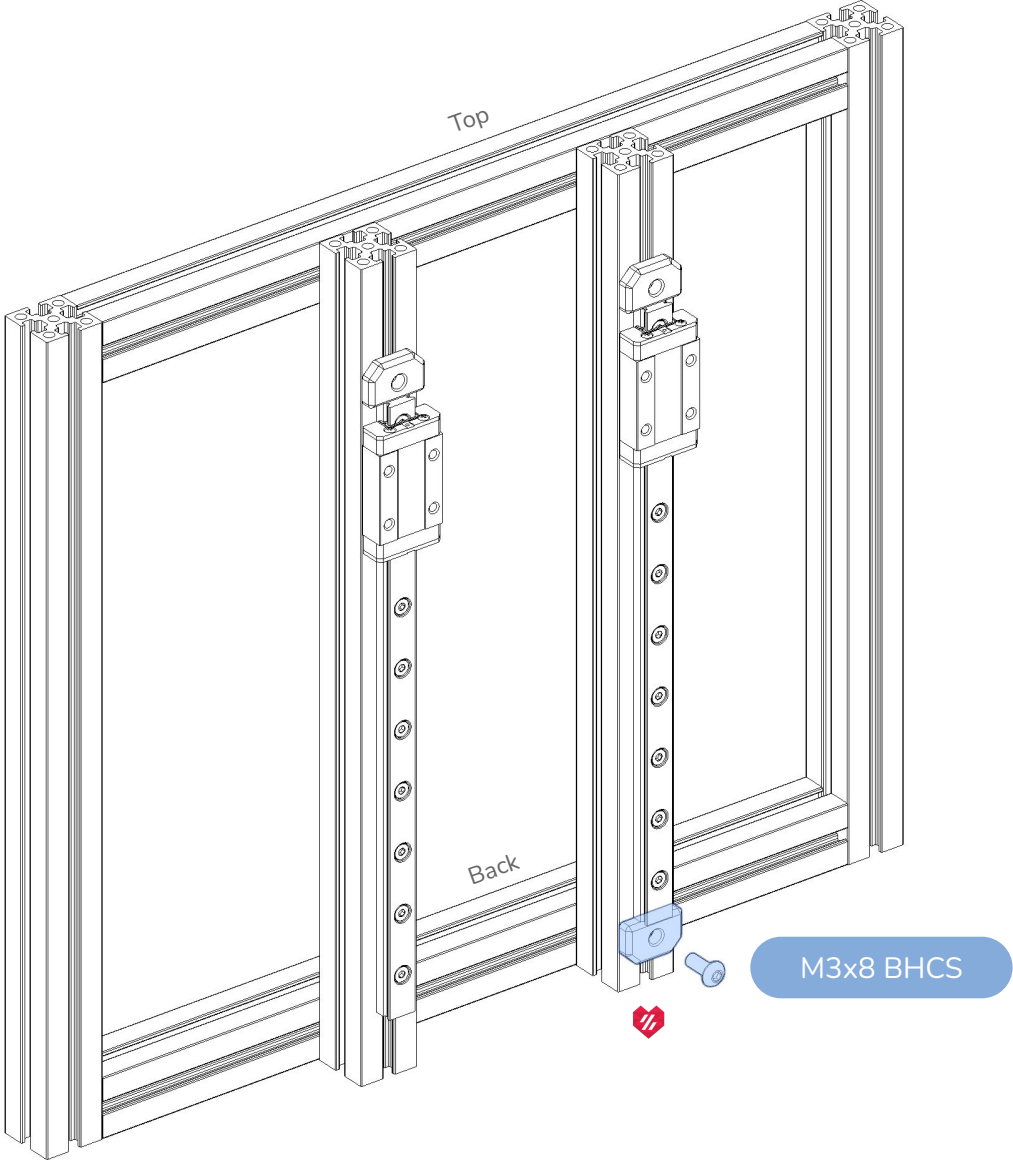

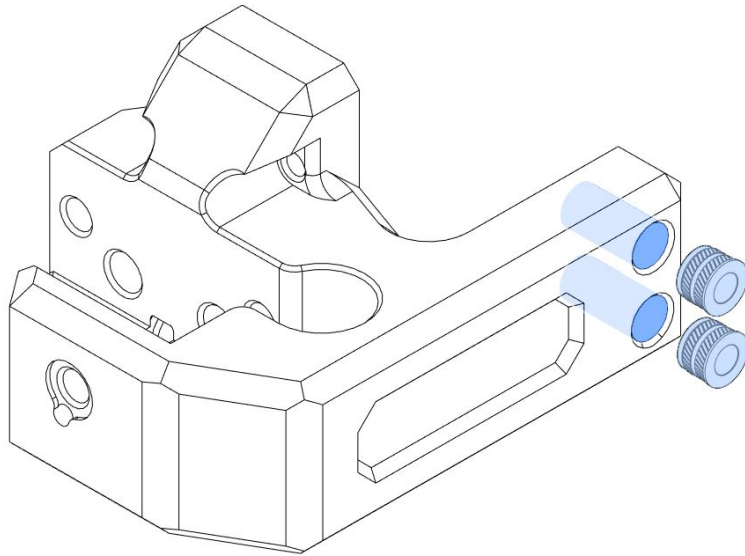

HEAT SET INSERTS

This design relies heavily on heat set inserts. Make sure you got the proper inserts (check the hardware reference for a close up picture).

If you have never worked with heat set inserts before, we recommend you watch a guide.



<https://voron.link/cubk4lh>

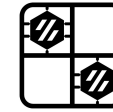

THE ANCIENT ART OF KIRIGAMI

If you have the Kirigami bed kit, you can attach it now and skip to page 47. Don't forget to attach your drag chain end link. You can find the files that are specific to the Kirigami bed at <https://voron.link/ysbmad9>.

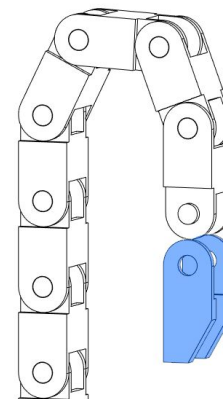
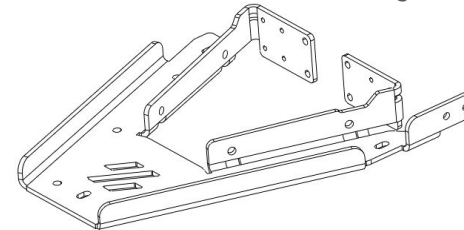

REMOVE THE END LINK

We need to attach the end link in the next step. Reattaching the rest of the chain later makes the assembly a lot easier.

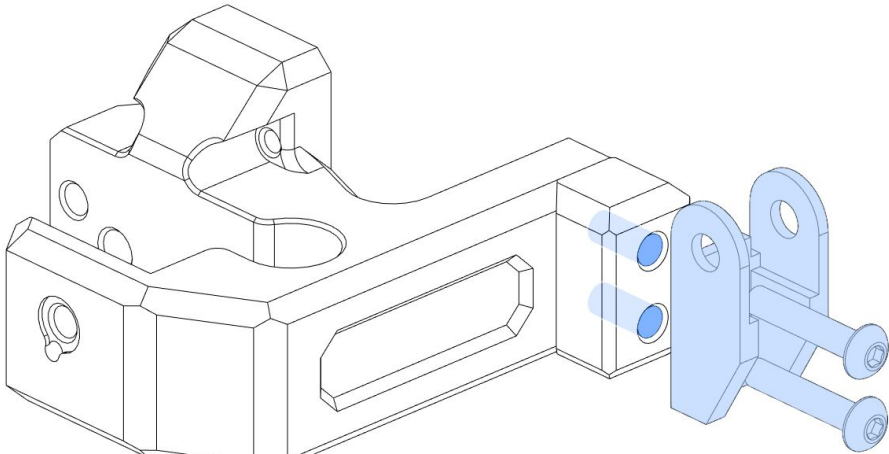
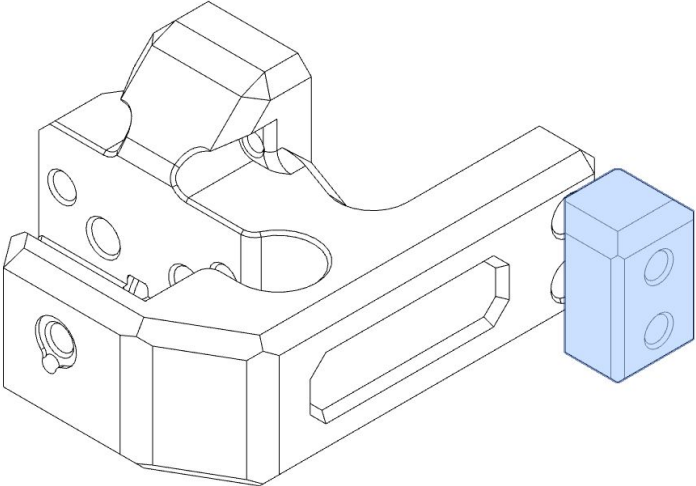

M3x16 BHCS

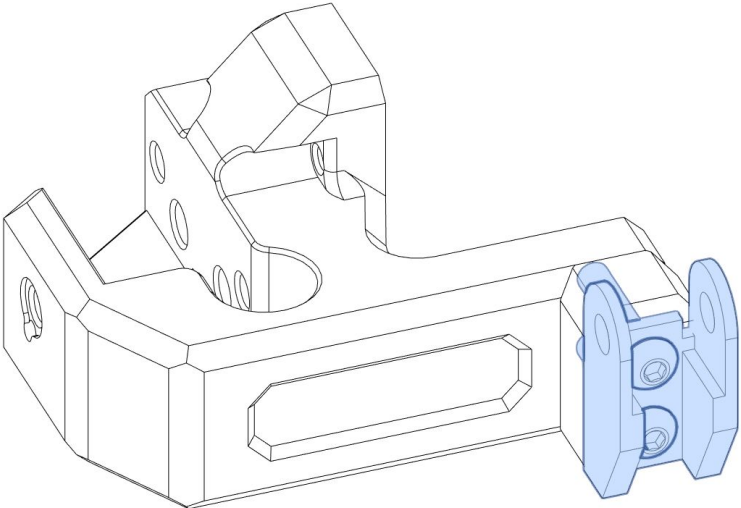

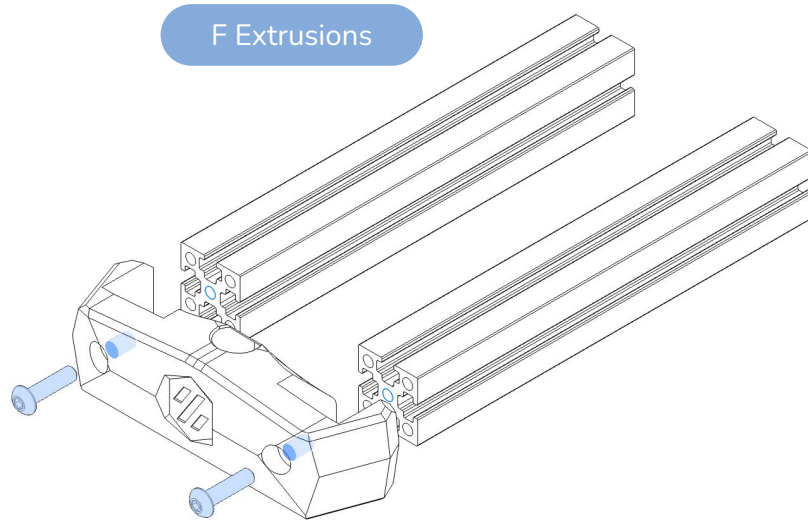

F Extrusions

M3x12 BHCS



WHAT DO THE SCREWS GO INTO!?

A hex nut can easily be inserted into the extrusion slot at this step to accompany these two screws. Therefore, it is not called out explicitly. **You can assume that all screws that enter extrusion slots must have a nut.** If a screw does NOT thread into a nut or a tapped extrusion end, we will explicitly state this. You can also reference the CAD assembly as all nuts are present there.

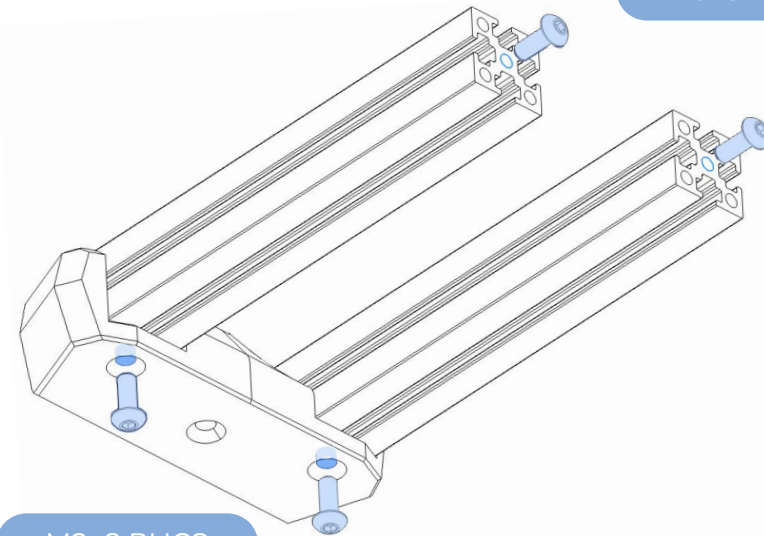

M3x8 BHCS

M3x8 BHCS

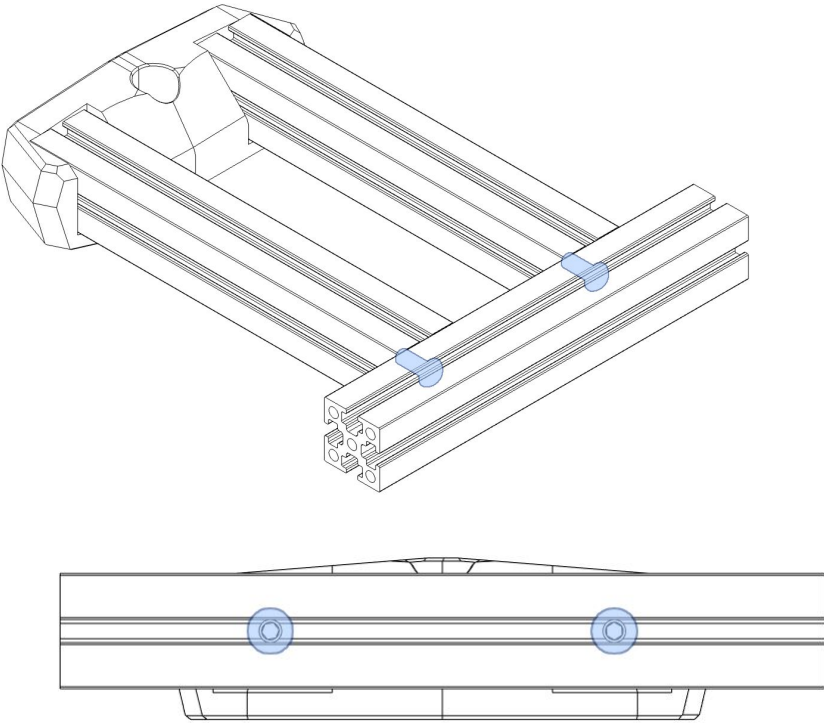
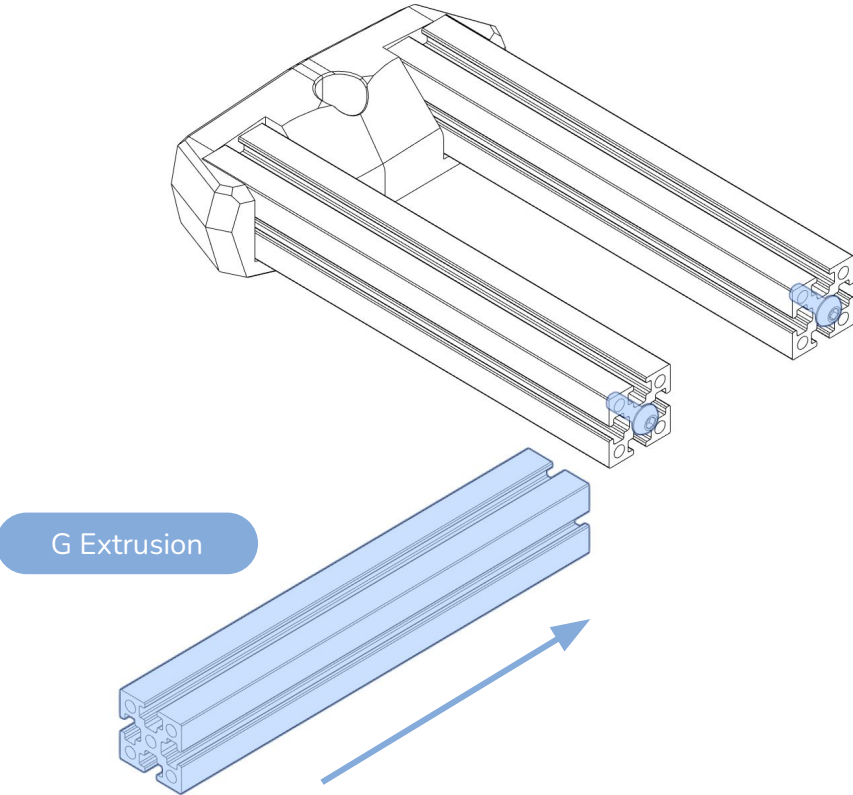

WRENCH ACCESS
Use a 2mm hex drive to tighten the screws behind the access holes.

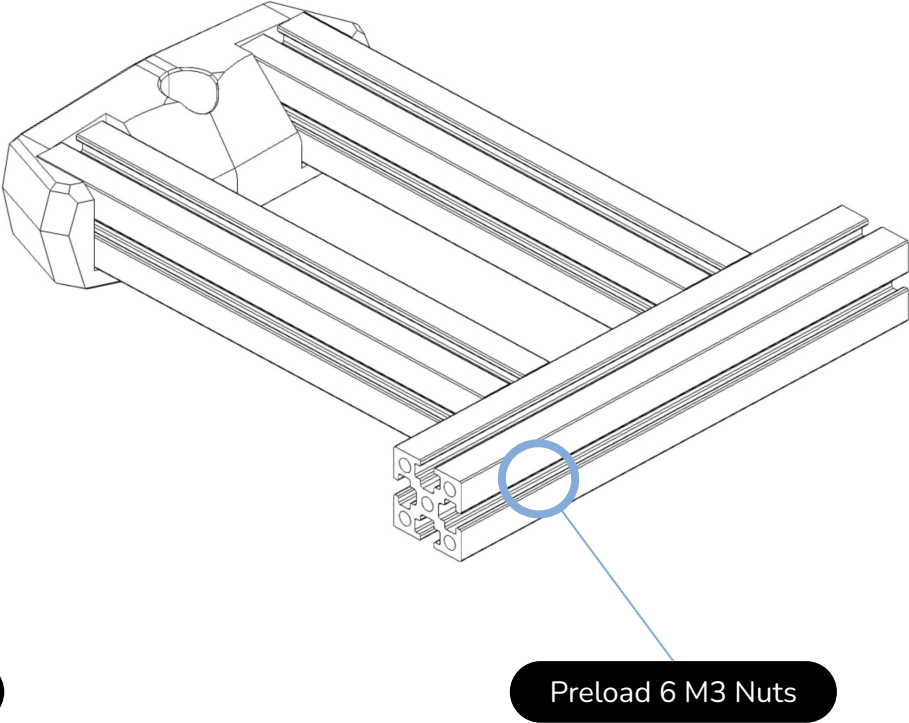
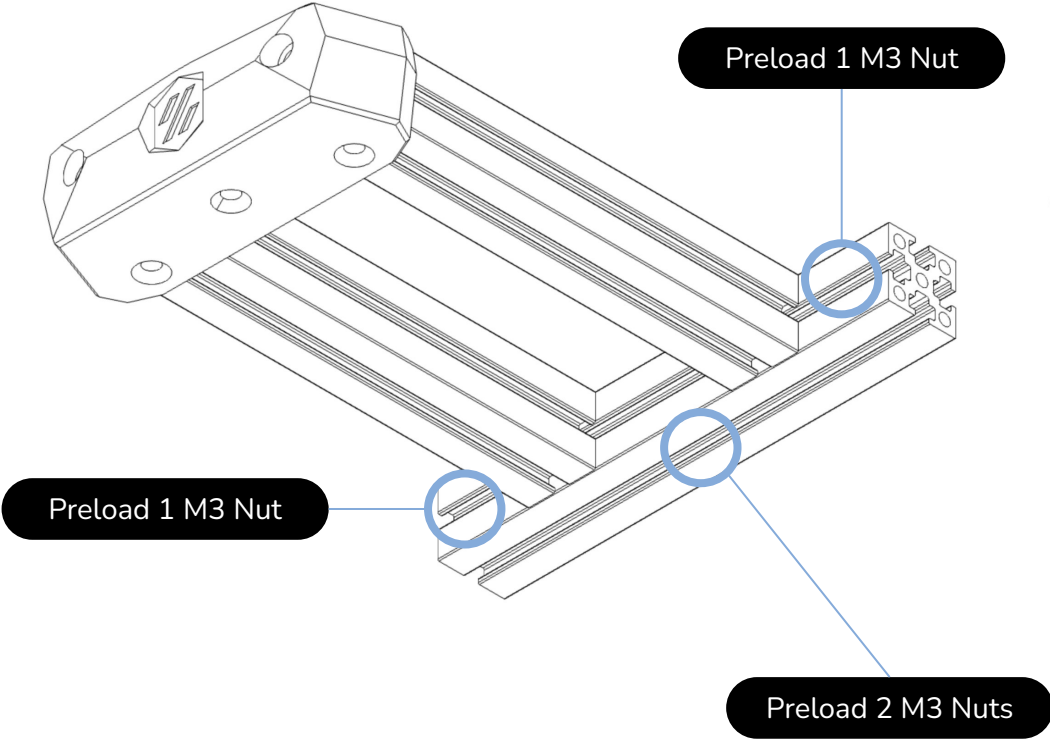

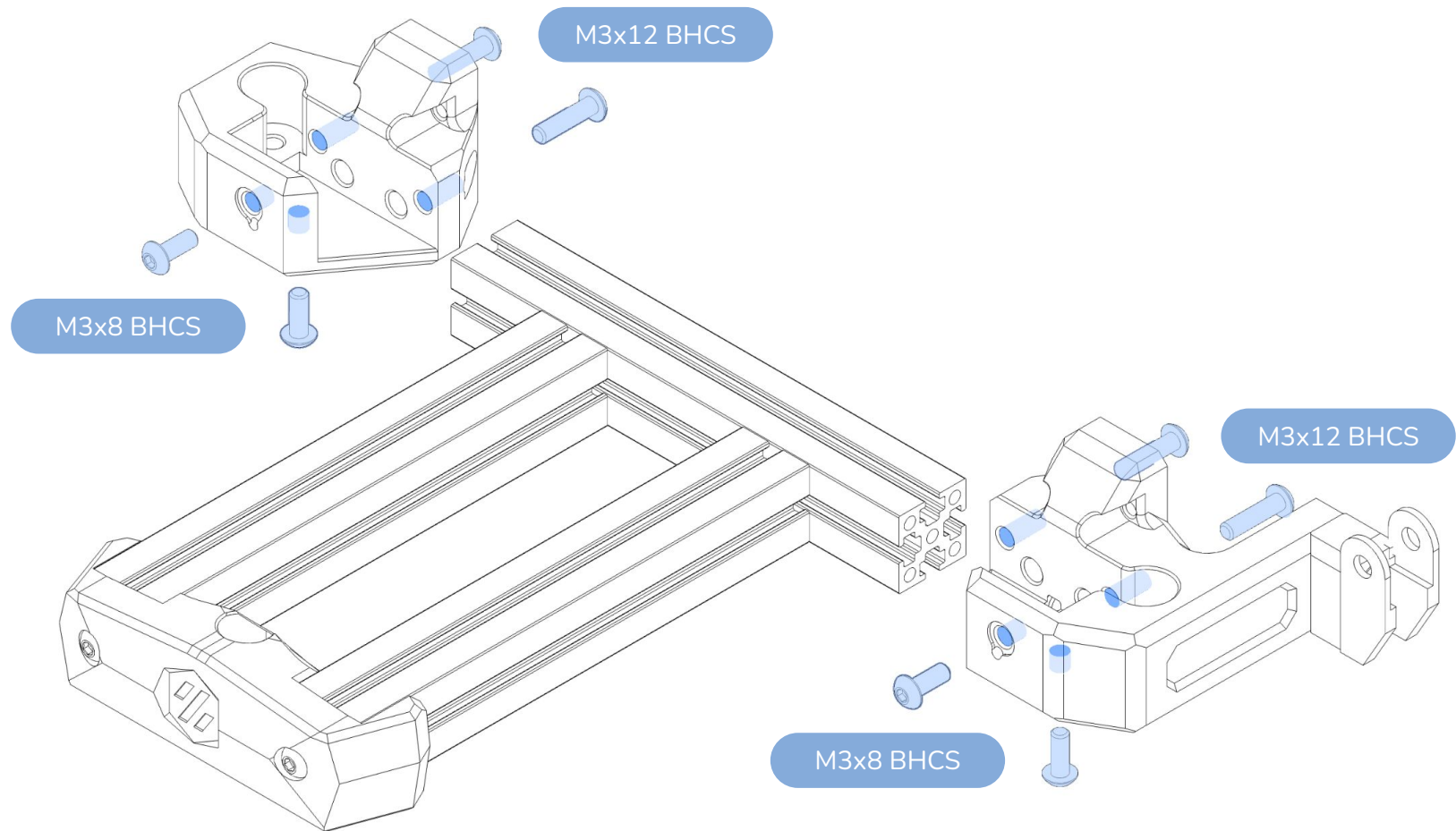

TWO STEPS FORWARD, ONE STEP BACK

We need to temporarily attach the bed frame to the bed mounts. This is to ensure a proper fit and alignment of your bed assembly. We will be removing these mounts in a few steps to attach them to the rail carriages.

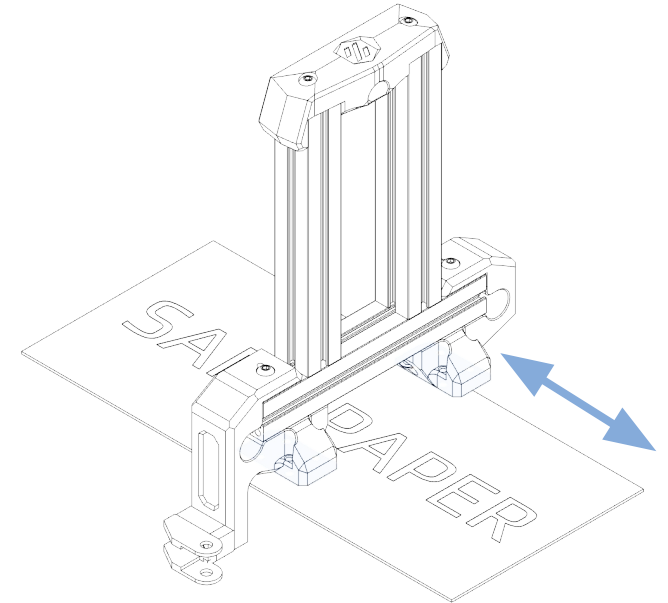
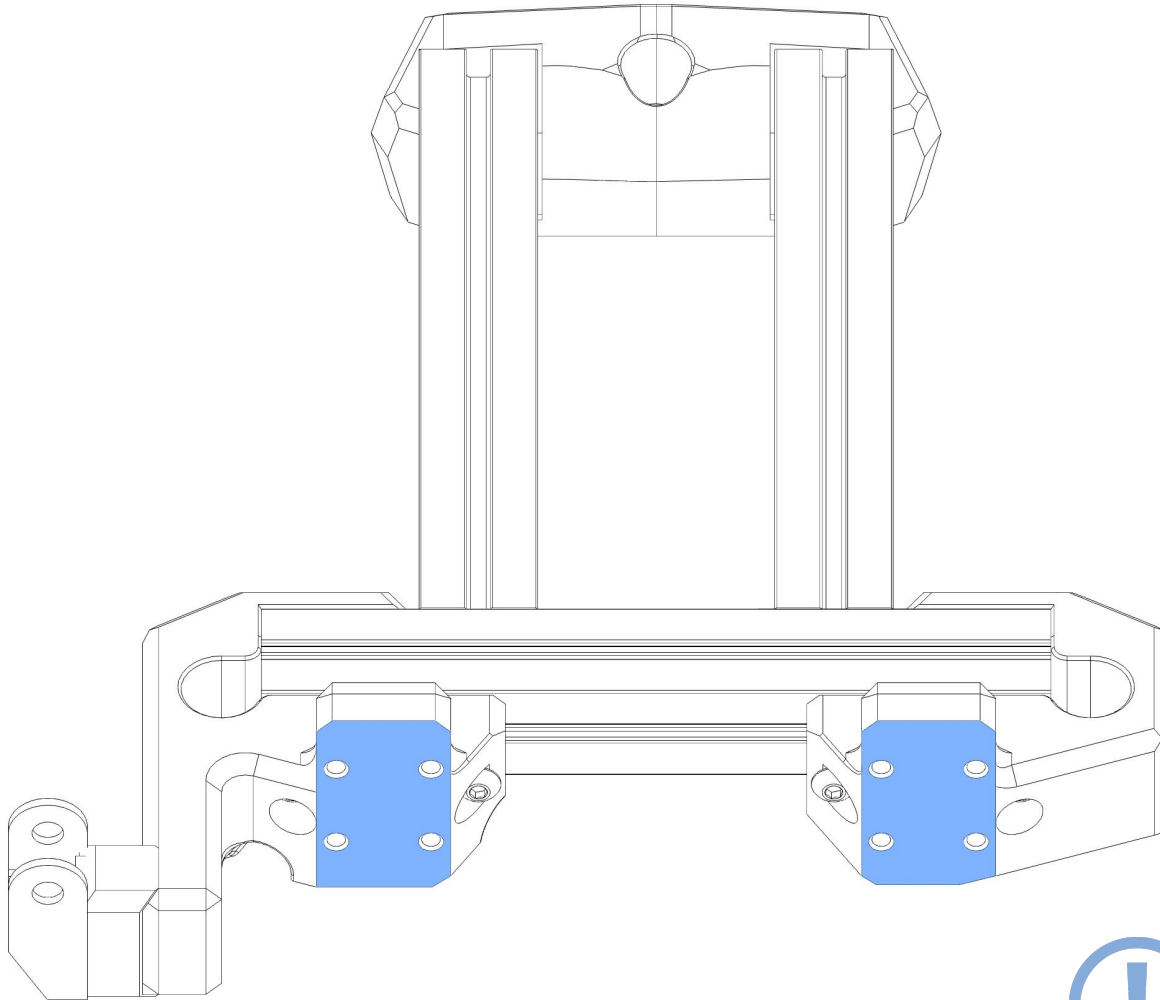

CHECK BED MOUNT FLATNESS

These two surfaces **MUST** be coplanar to prevent binding of the Z rails.

Lightly flat sanding both surfaces while they are mounted to the bed frame can ensure a quality fit down the line.

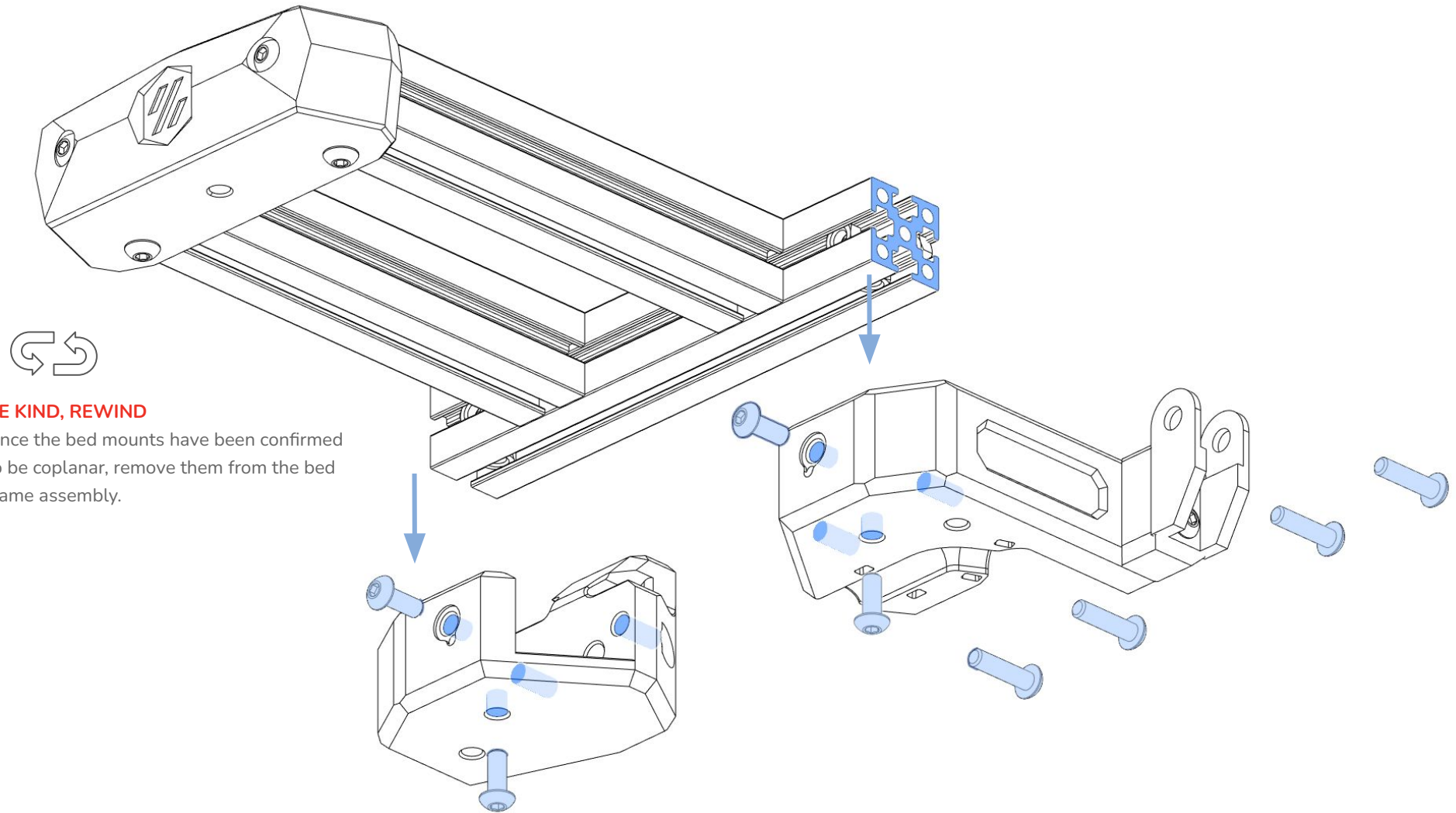

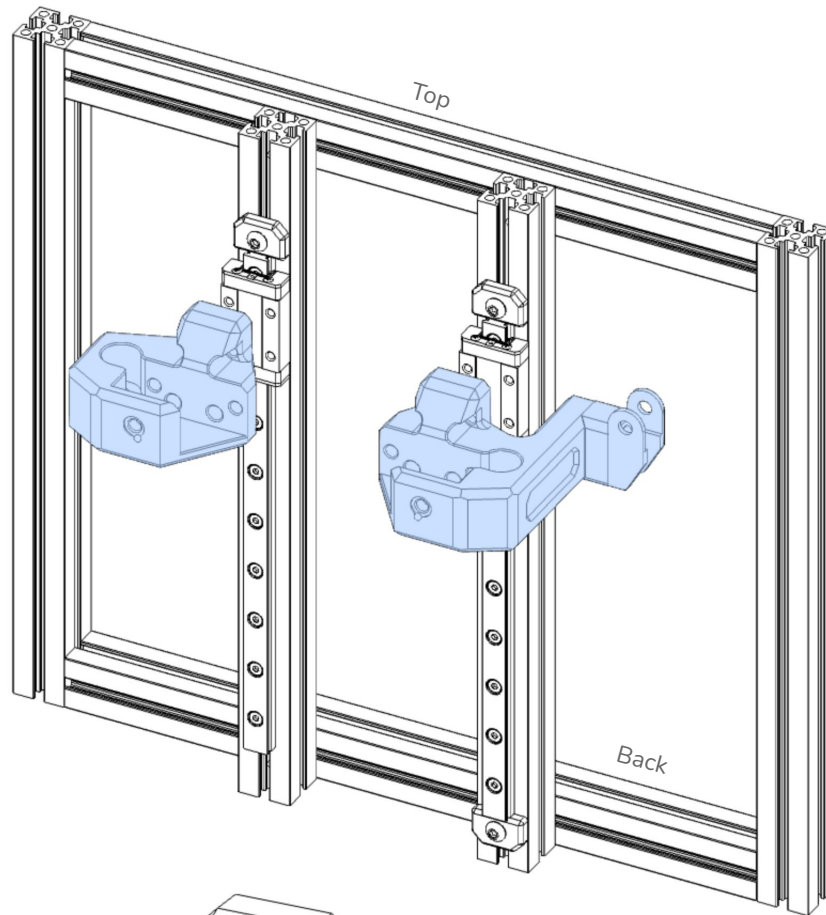

USE THREAD LOCKER

Carefully apply a small amount of thread locker to the screws.

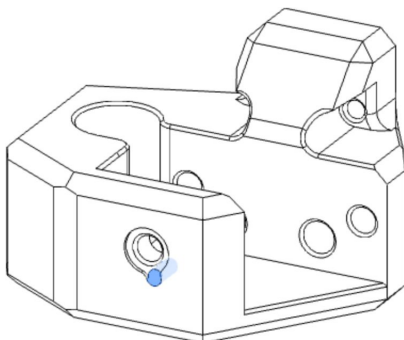
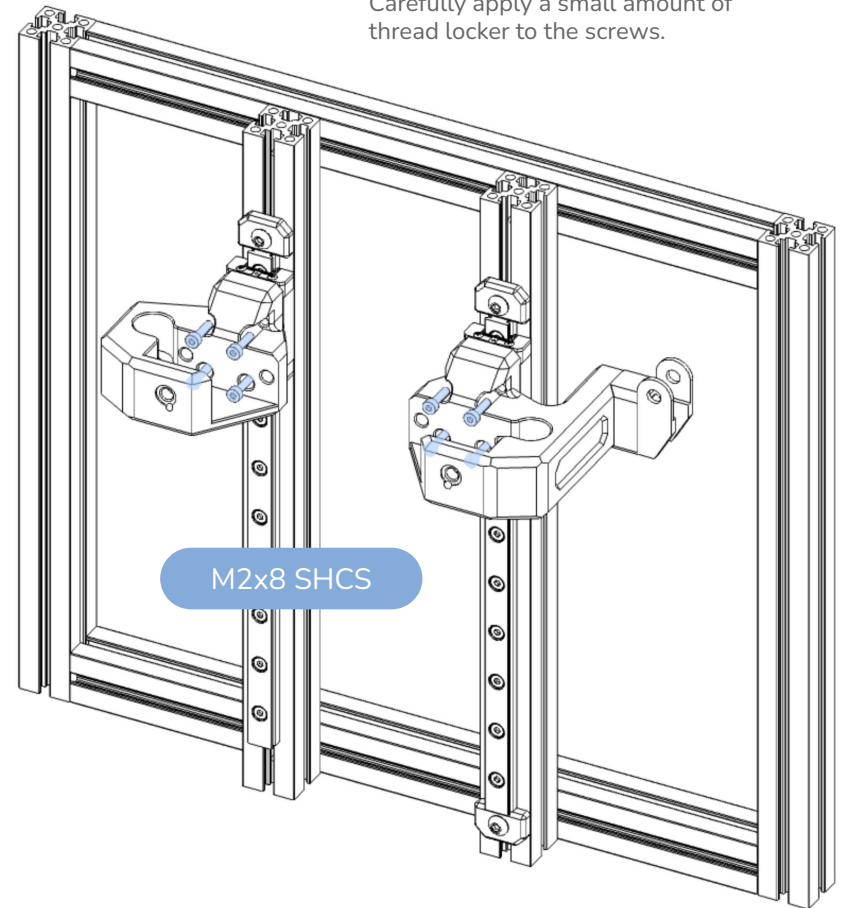

SCREW ACCESS HOLES

Use the small access holes and a long hex driver to fasten the hidden screws.

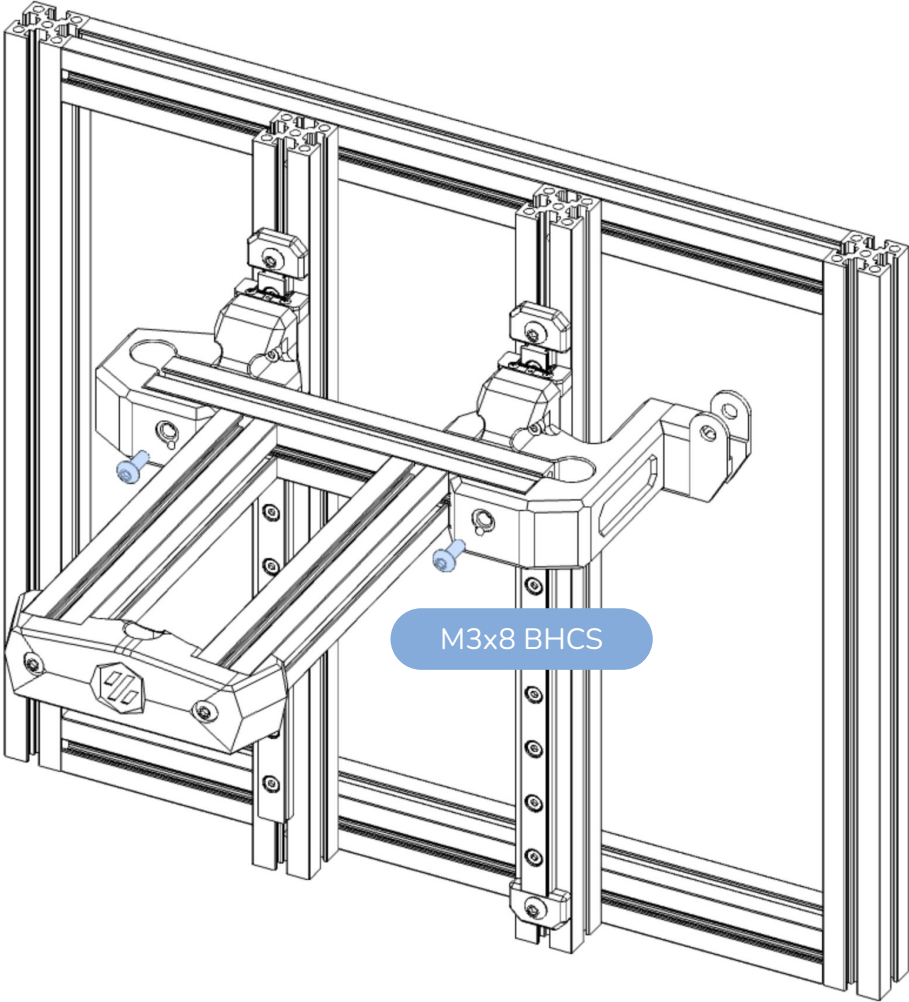
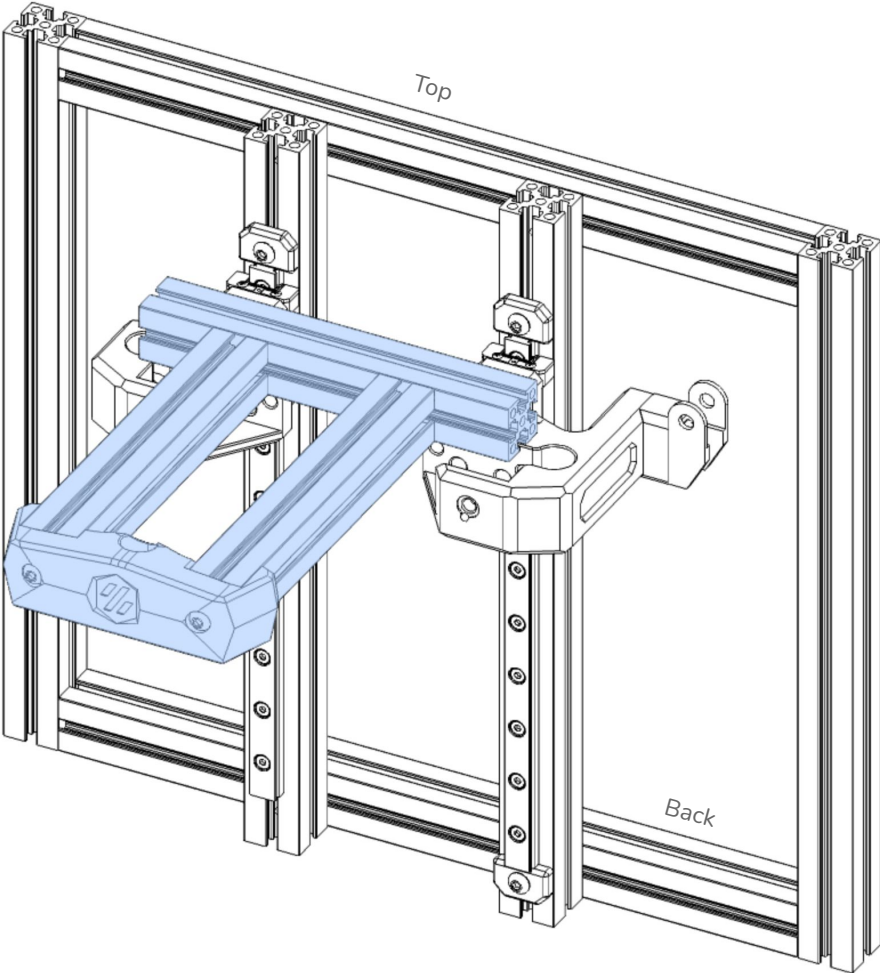

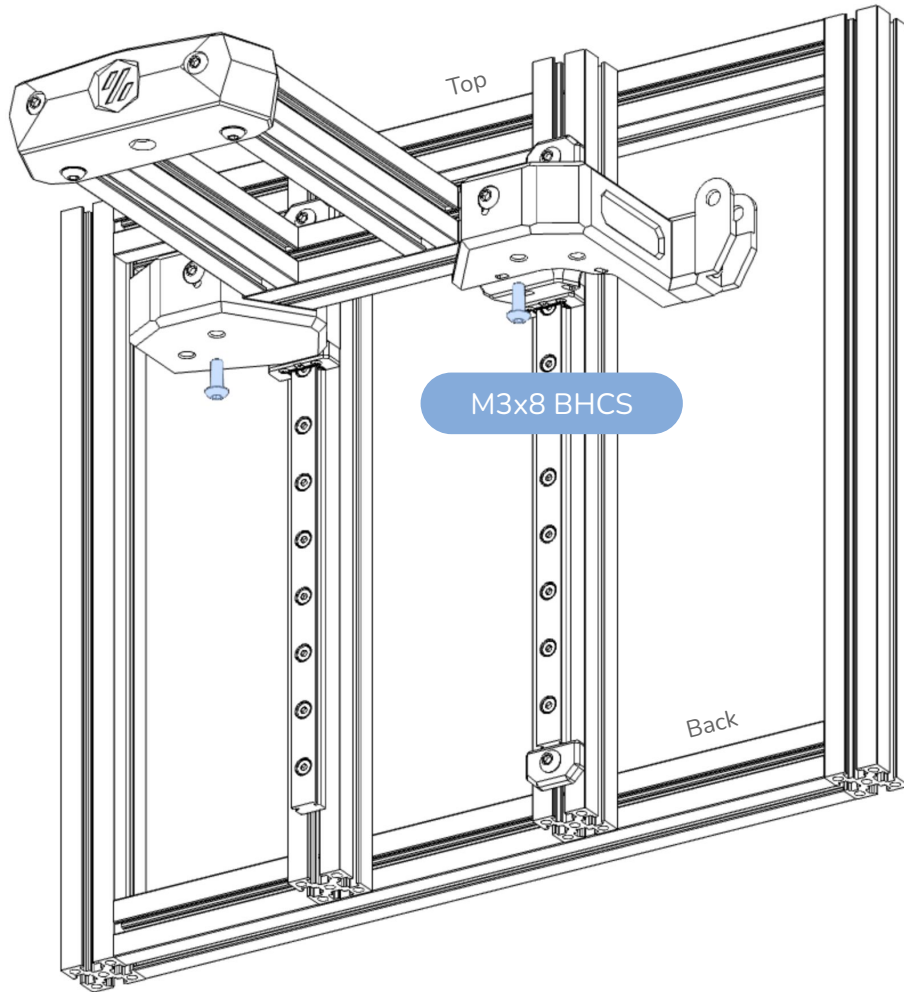

USE A BALL-END DRIVER
Use a 2mm ball-end driver to fasten the left screw.

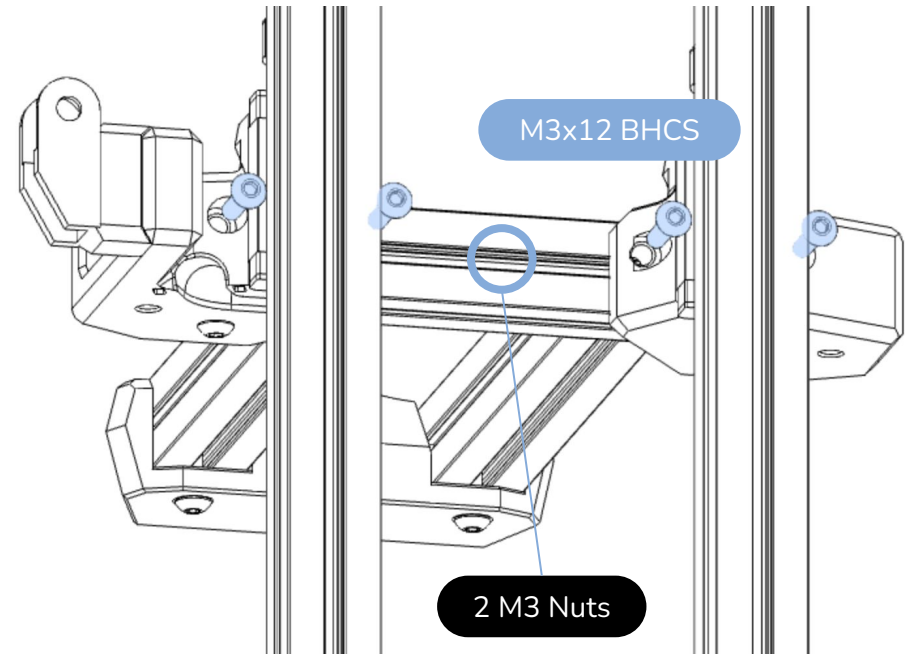

PRELOADED NUTS
Make sure that 2 of the preloaded nuts are located in the center.

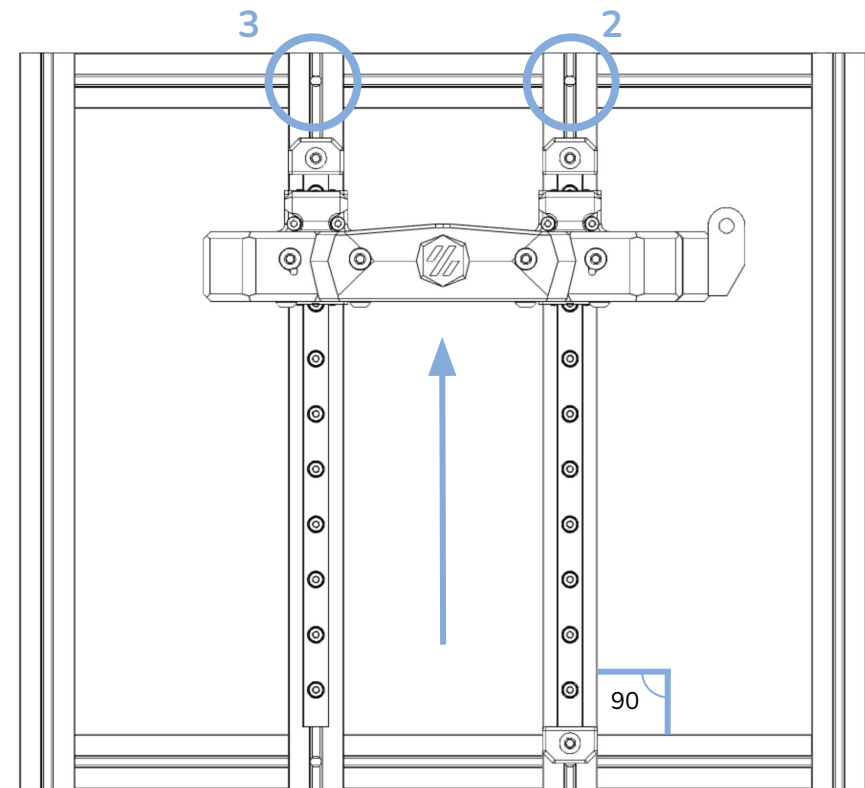
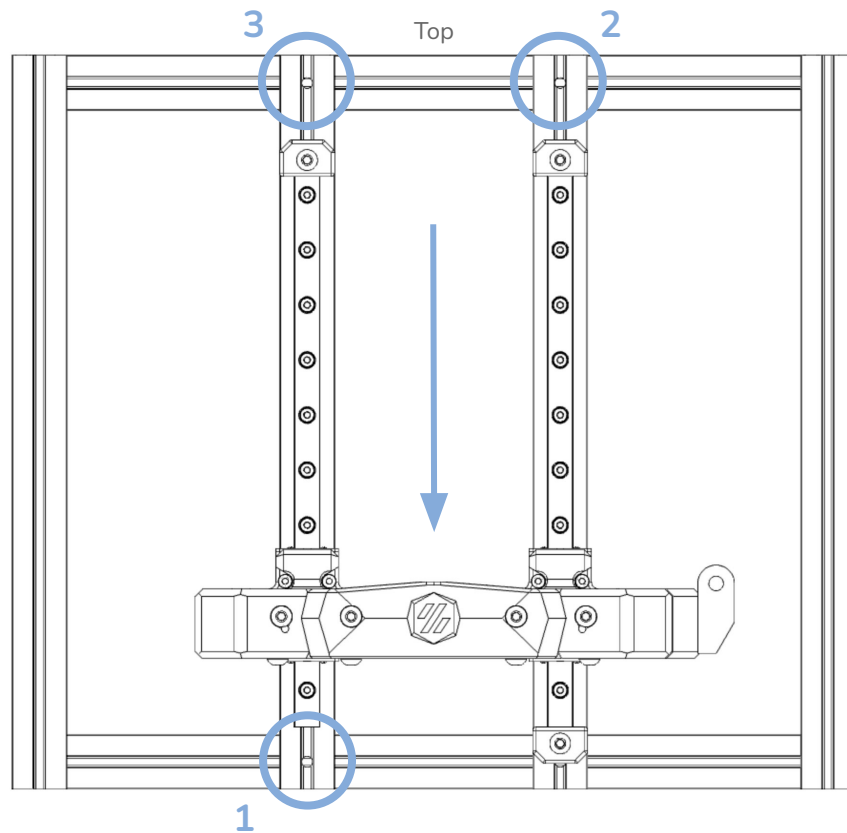

TRAMMING

Loosen these three screws and bring your bed assembly all the way to the bottom. Now that the Z rails are properly spaced and the bed assembly is in position, you can tighten screw number 1.

SQUARING

Move the bed assembly to the top and ensure that your Z extrusions are perpendicular to the frame, then tighten screw number 2. This should set the extrusion spacing at the top of the Z rails.

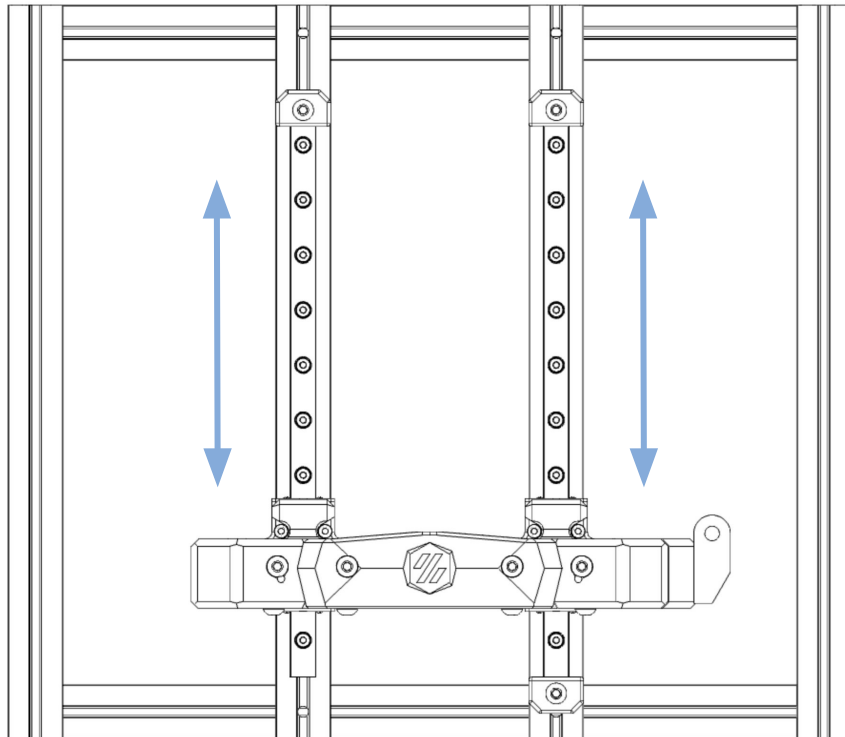

MORE TRAMMING

Check for any binding or snags while moving the bed carrier up and down the rails. The bed carrier must be able to move freely along the entire length of the rail. If it does not, loosen the blind joints of the Z extrusions and repeat the steps from the previous page.

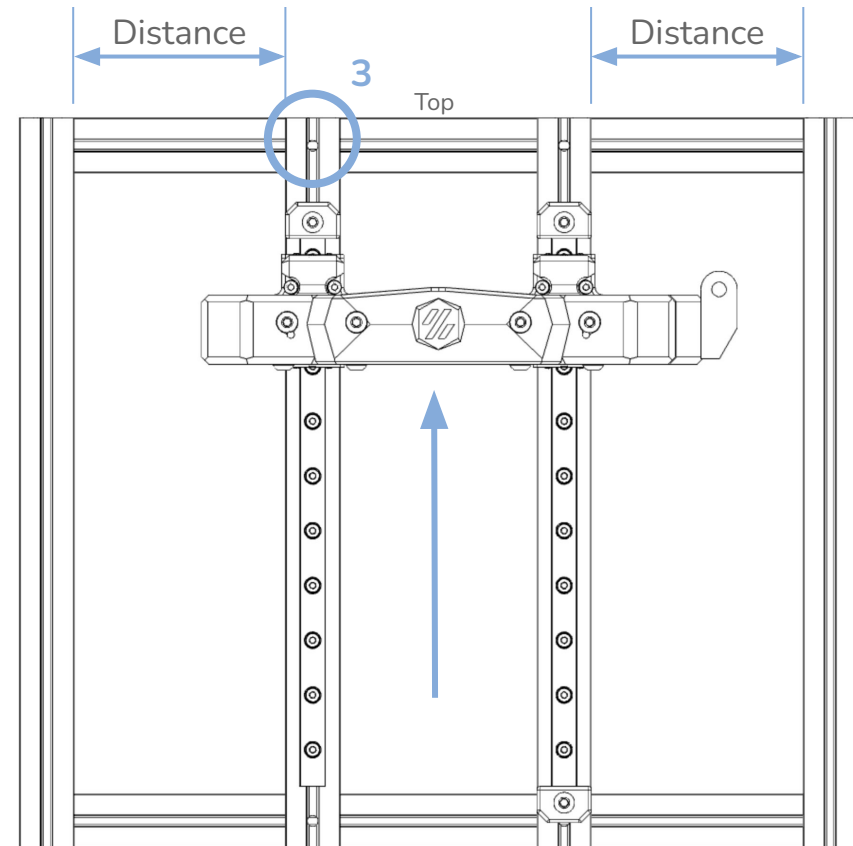

EVEN MORE TRAMMING

Move the bed carrier back to the top and then tighten screw number 3. Do one last check to ensure that your bed carrier has smooth motion up and down and there is no binding. Double check that the two distance measurements are as equal to one another as you can get, this will ensure that your bed is centered left to right in the printer frame.

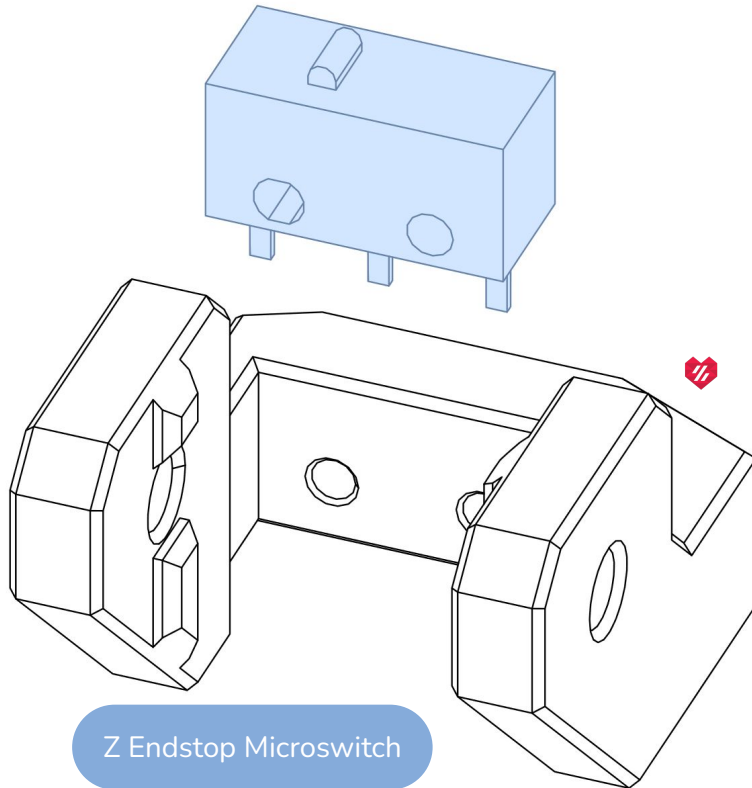

REMOVE THE LEVER

Remove the metal lever from the endstop switch. Double-check that the orientation of the switch matches the image above.

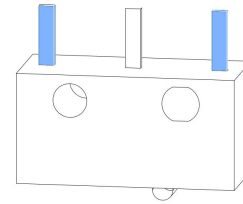

PREPARE ONE ENDSTOP SWITCH

Prepare the switch for Z by soldering wire to the two outer terminal. This will setup the switch in a Normally Closed state which is preferred for endstops.

MIND THE SWITCH ORIENTATION

Pay attention to the position of the switch button.

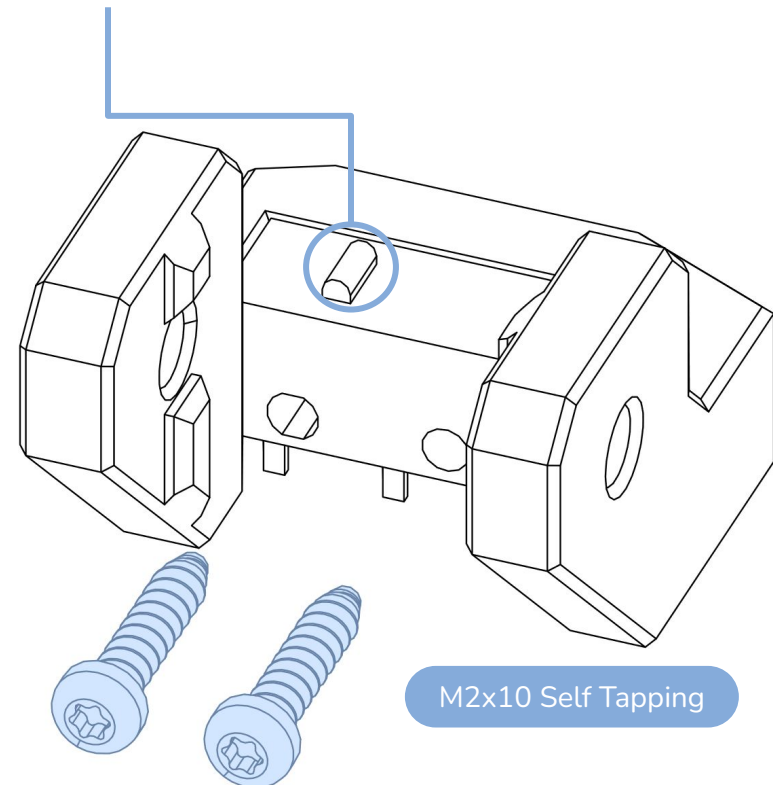

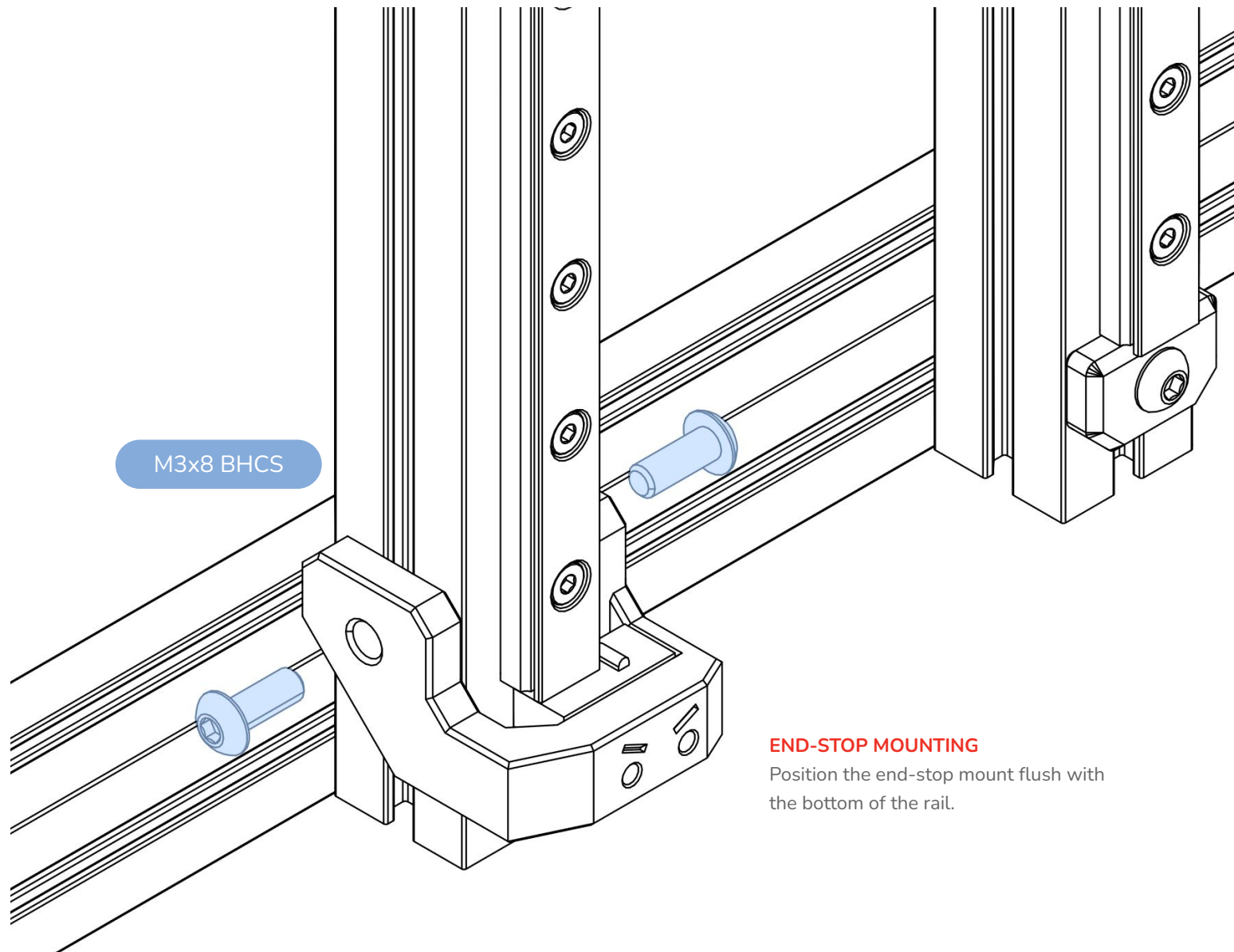

END-STOP MOUNTING

Position the end-stop mount flush with the bottom of the rail.

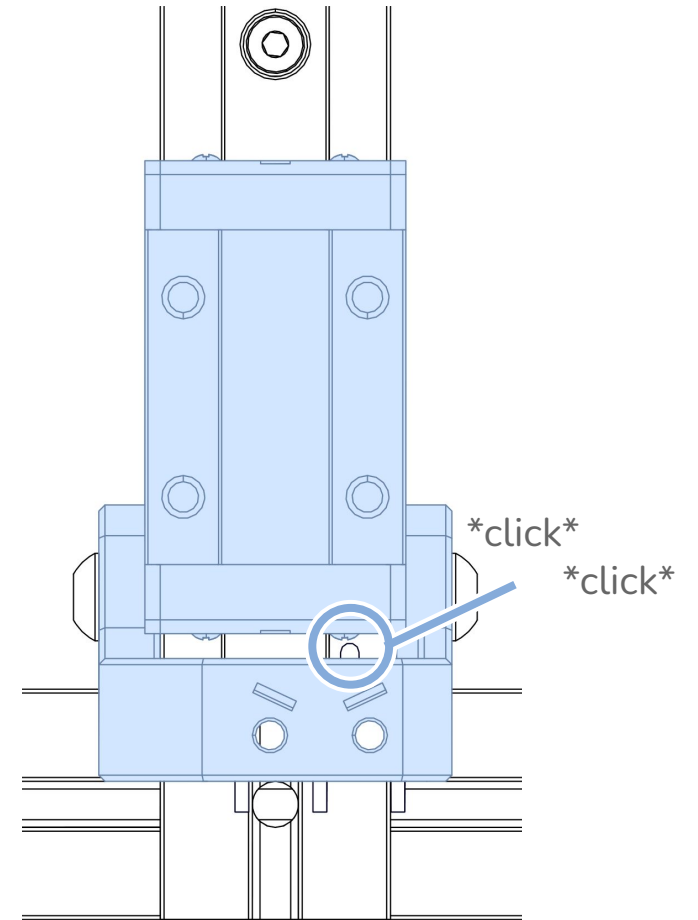
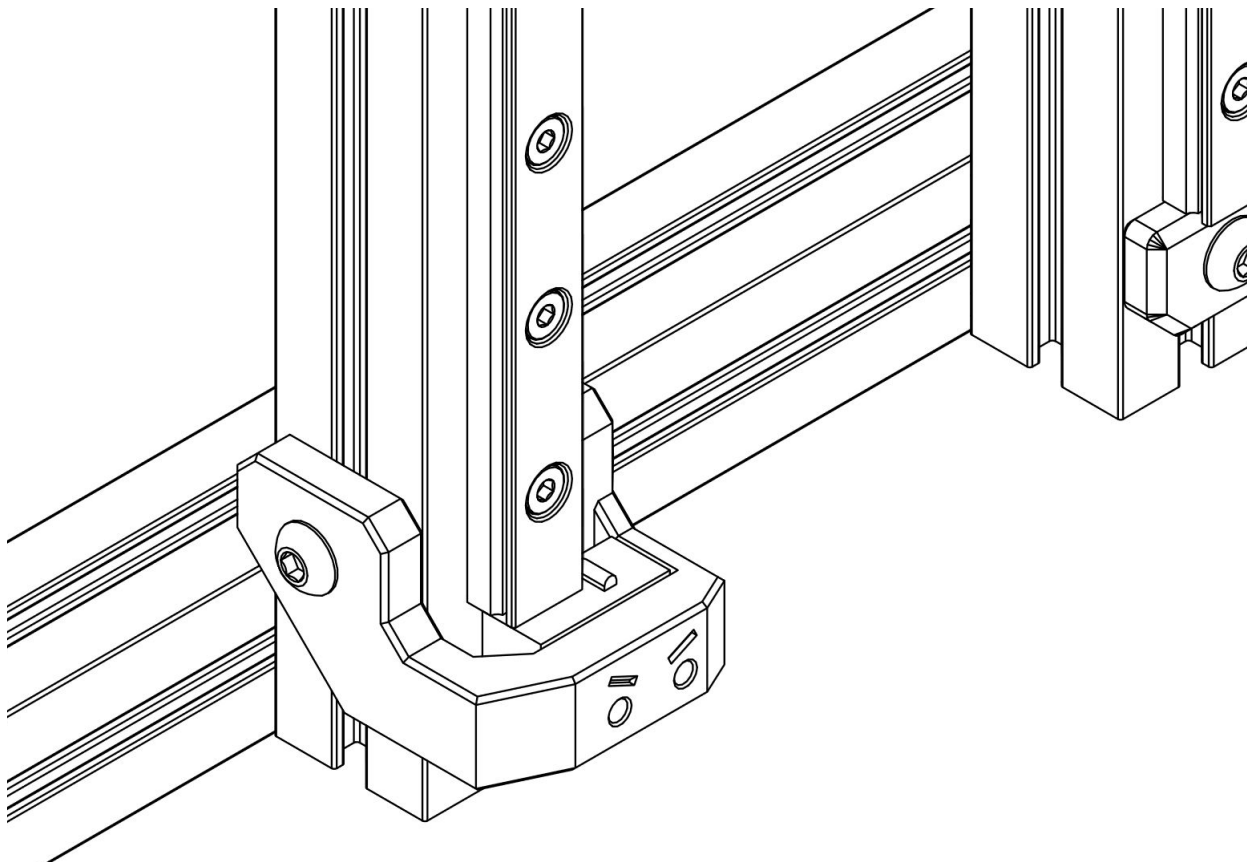

TEST FUNCTION

Carefully slide the bed assembly down and ensure that the carriage triggers the endstop switch. You should hear an audible click.

LEAVE THEM ALONE

Leave the screws in place we will be re-using them in the next step

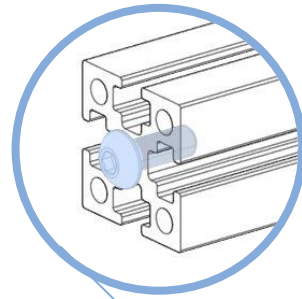

Preload 2 M3 Nuts

Preload 1 M3 Nut

Preload 2 M3 Nuts

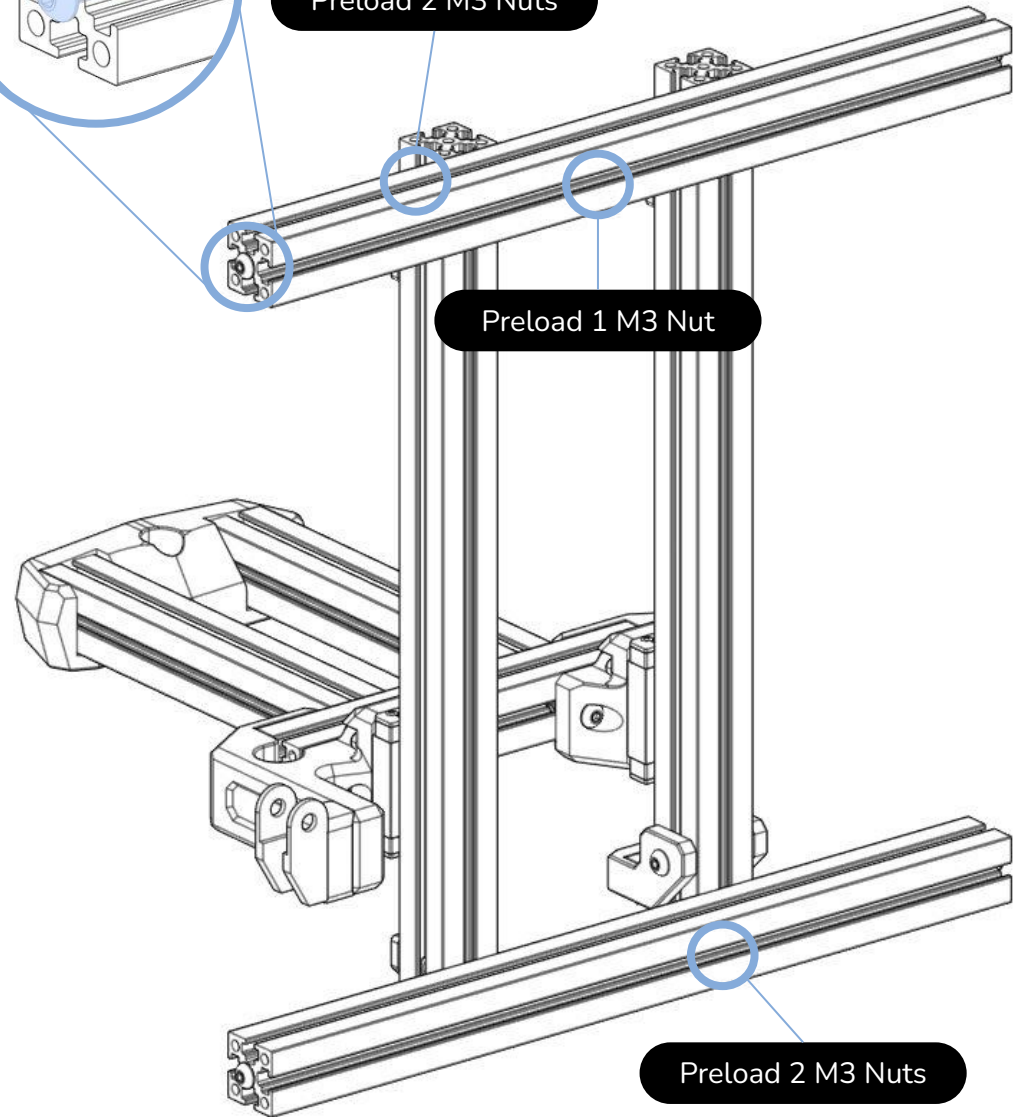
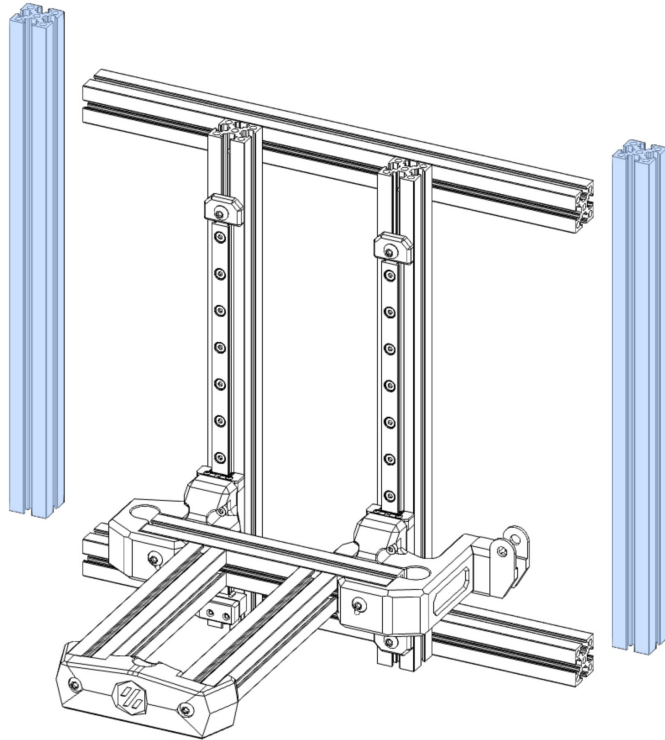

REMOVE UPRIGHTS

The extrusions were temporarily attached to help with the trammung.

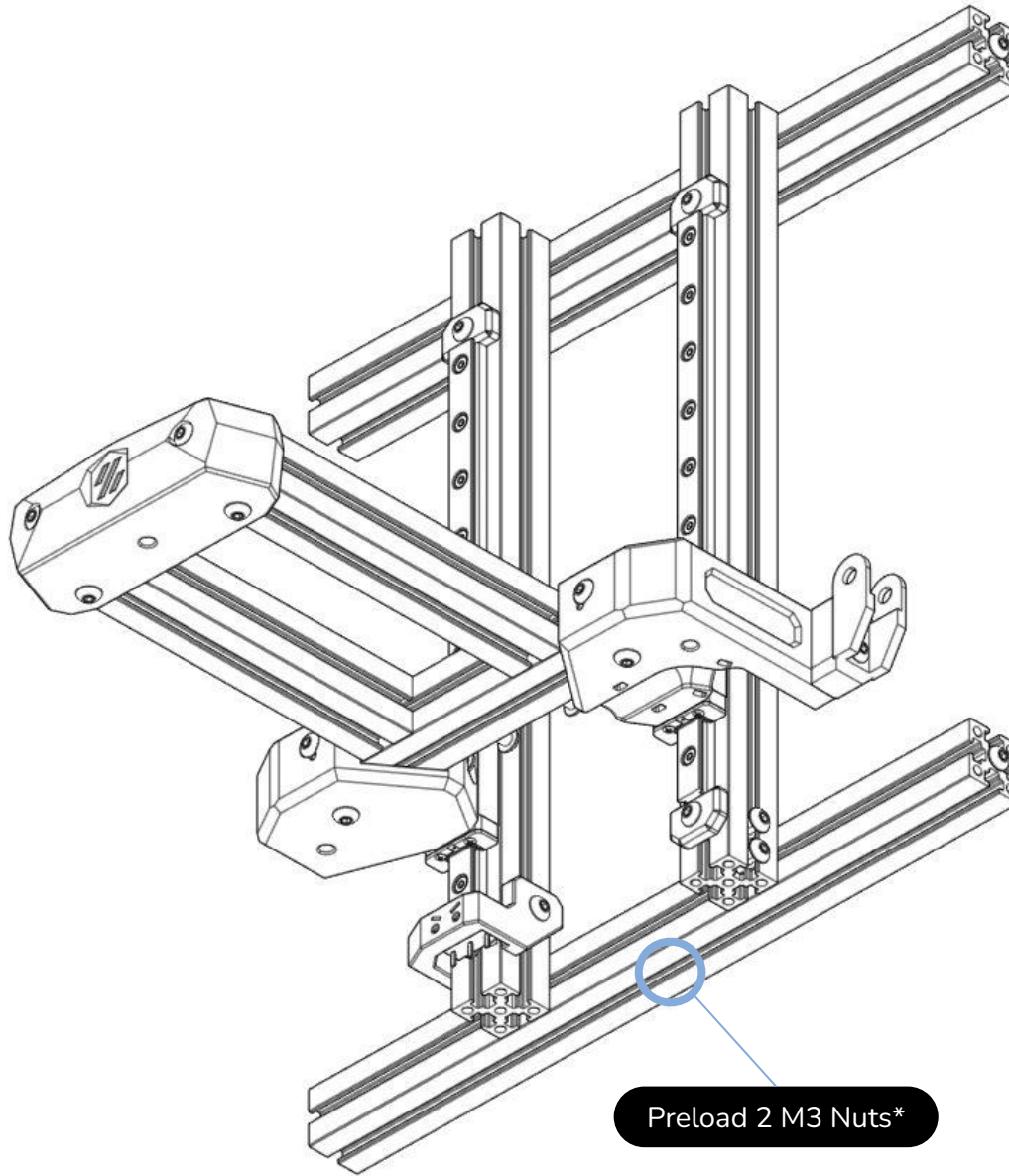

***5v POWER**

If your MCU does not supply 5v power to your Raspberry Pi you are going to need to mount a 5v power source. Adding additional nuts into this slot, beyond the 2 called out here that are for the Z motor mount, can provide a secure mounting point if your 5v psu has screw mounting holes.

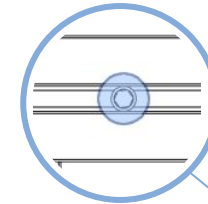
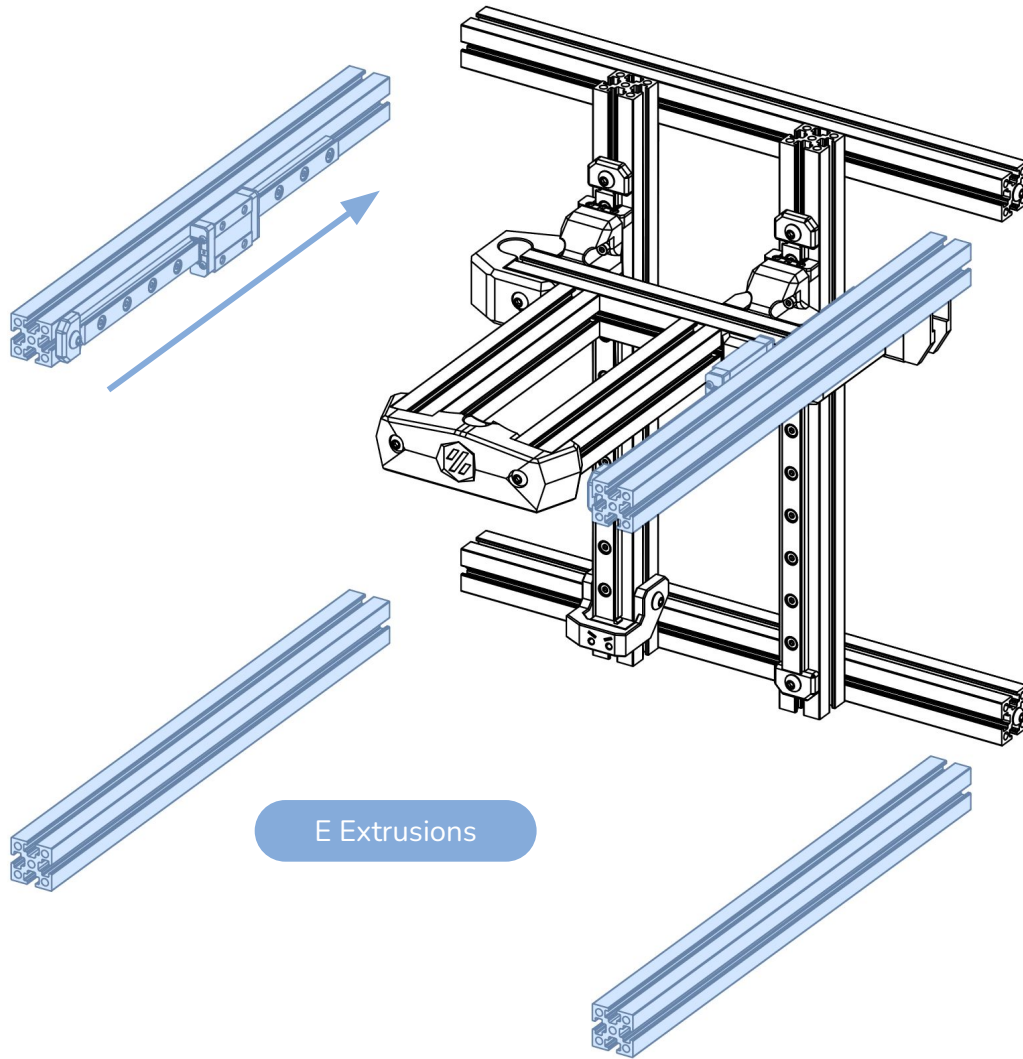

WRENCH ACCESS

Use a 2mm hex drive to tighten the screws behind the access holes.

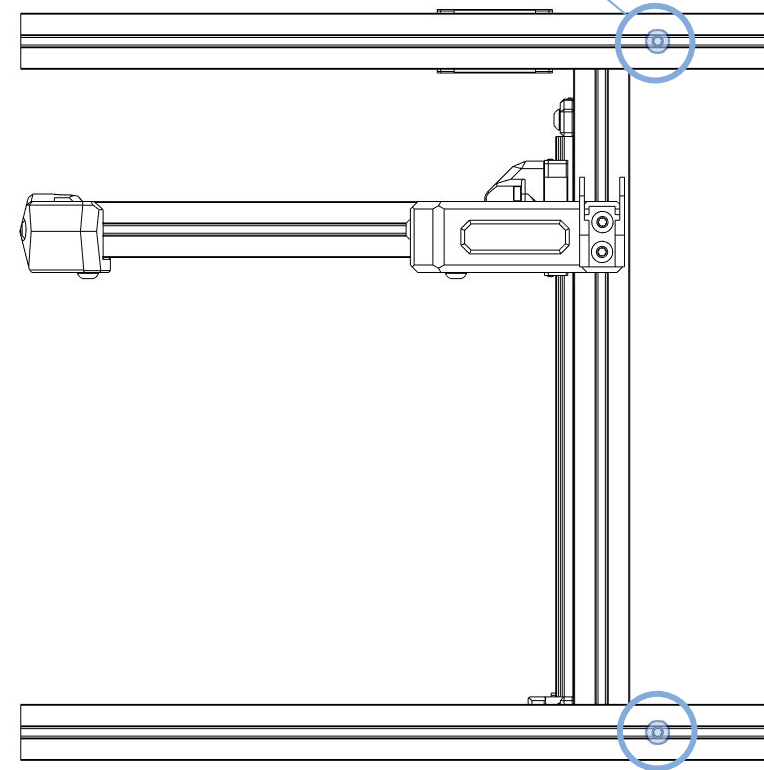

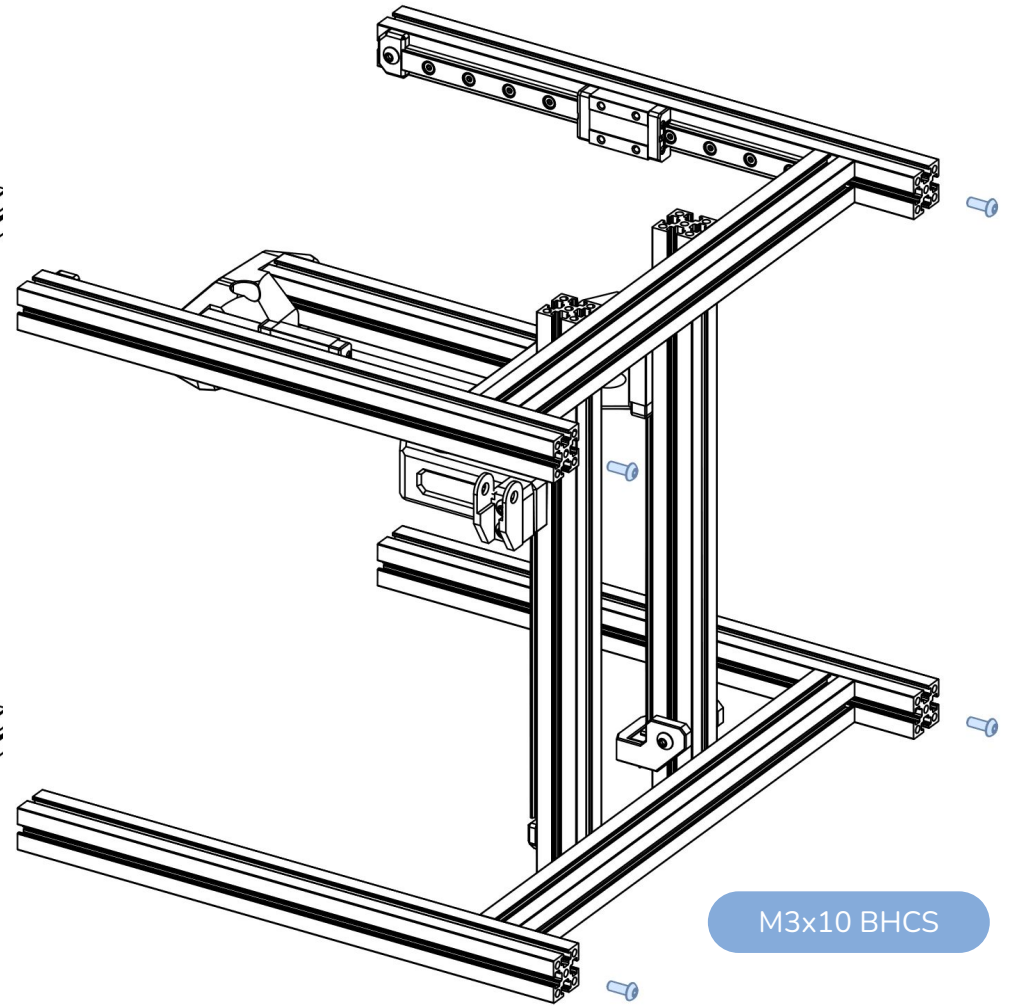
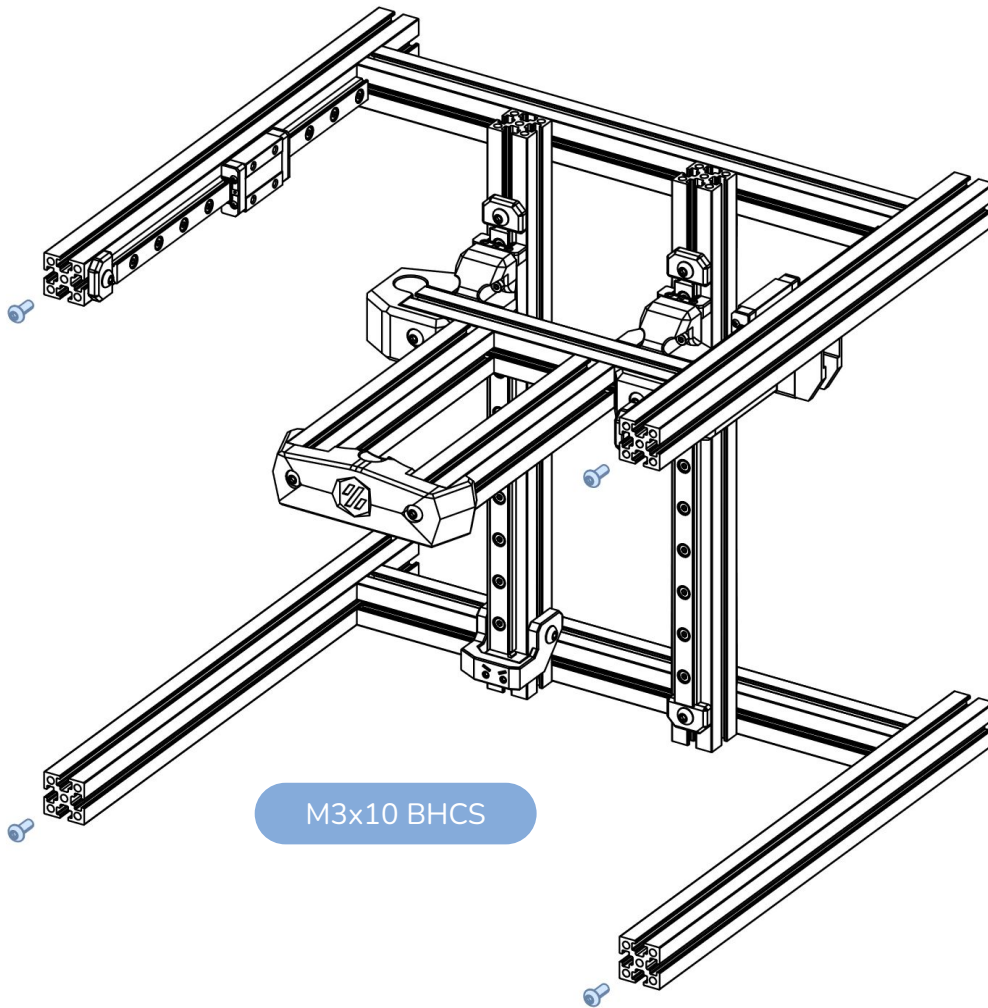

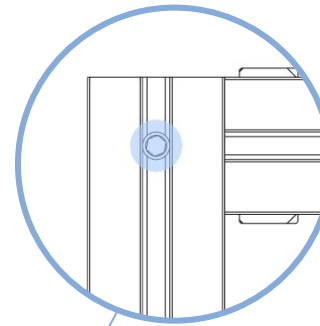
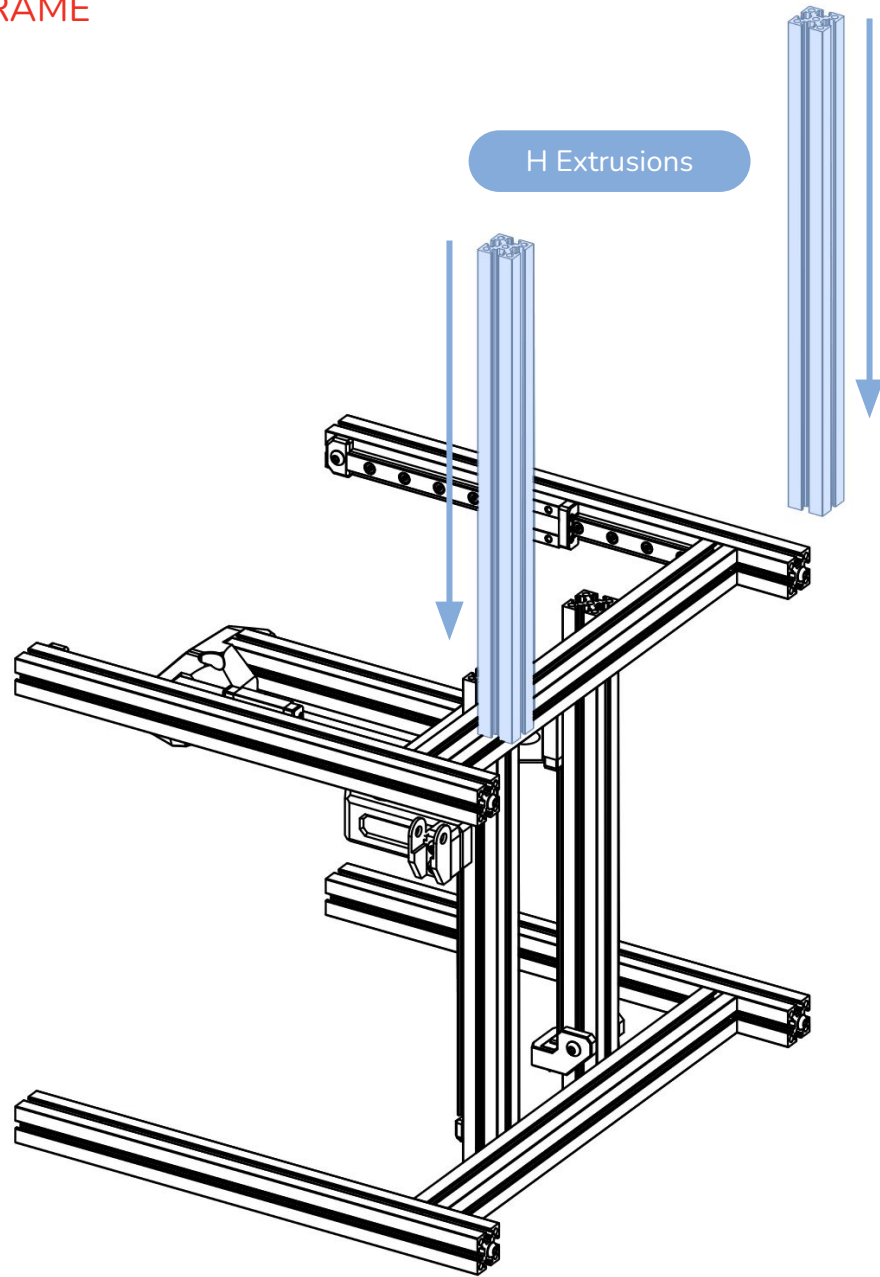

WRENCH ACCESS

Use a 2mm hex drive to loosely tighten the screws behind the access holes.

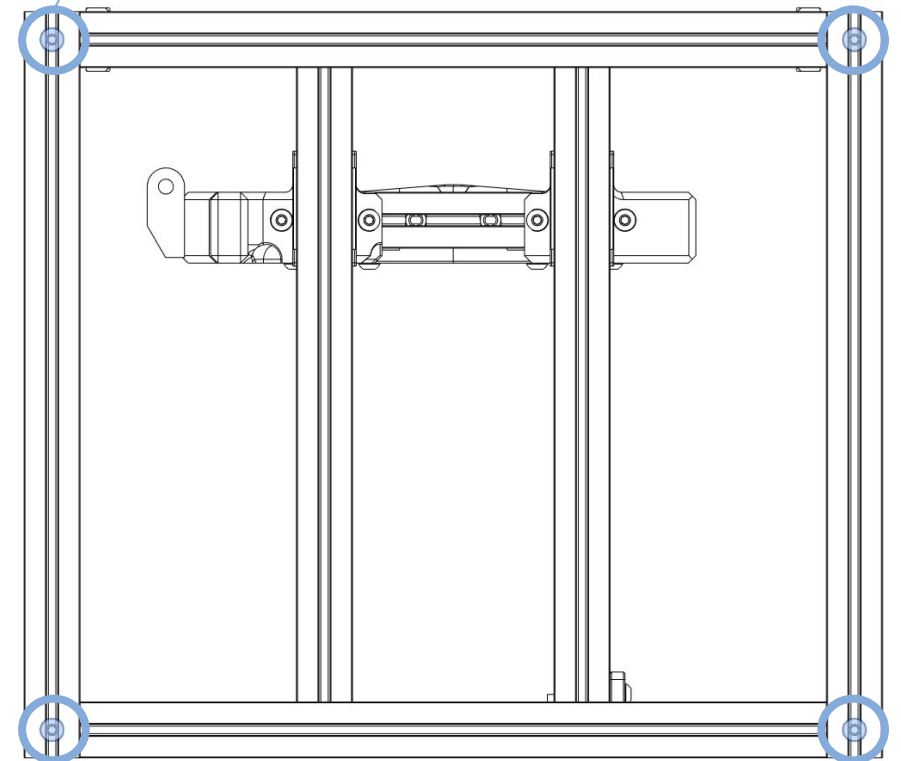

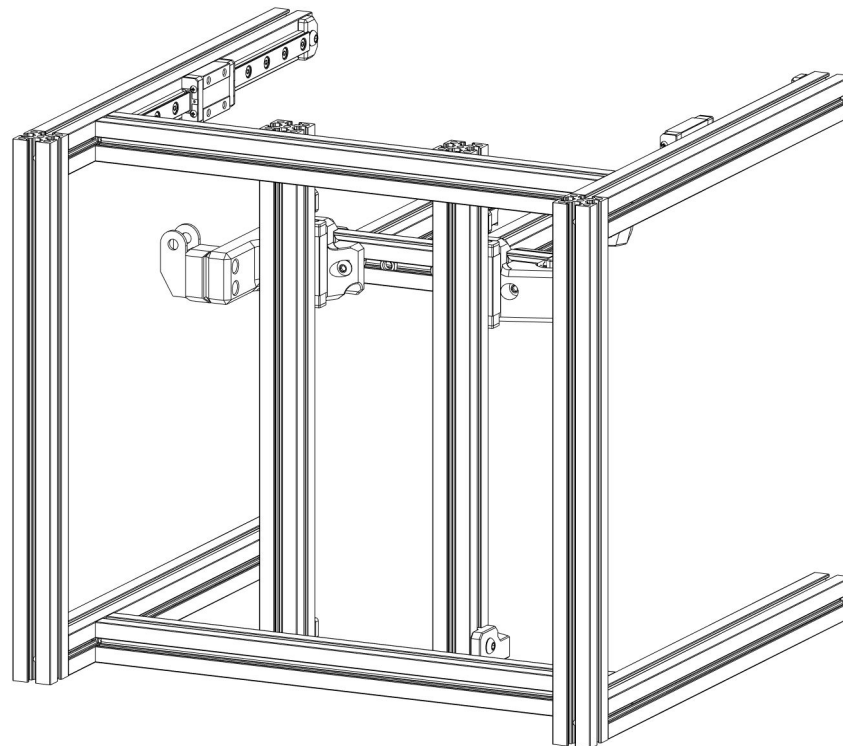
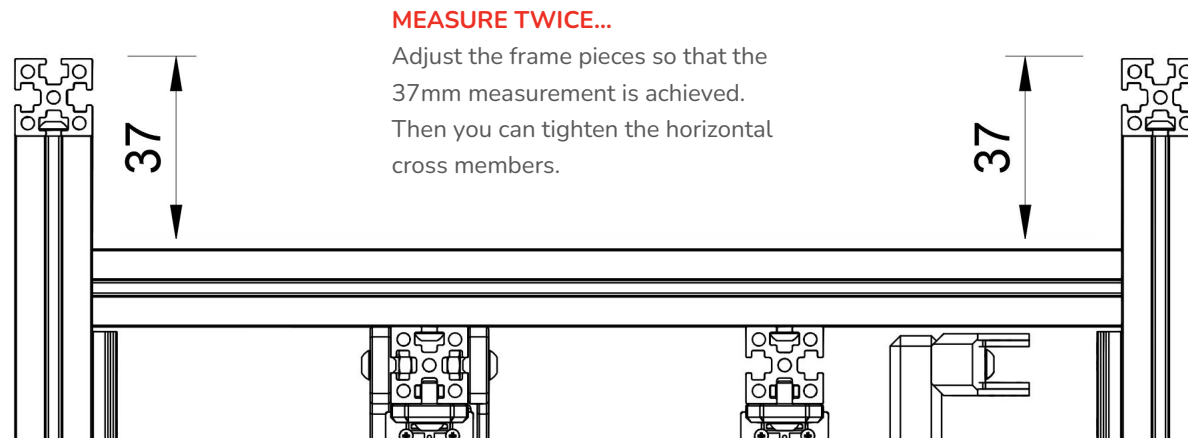

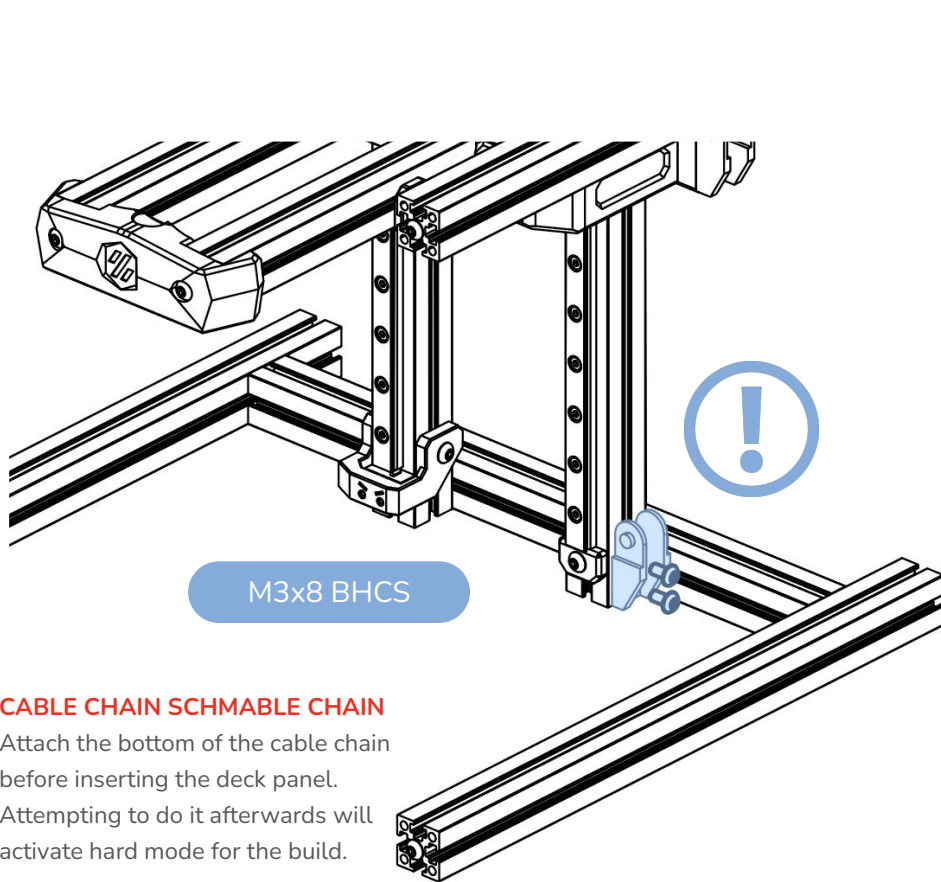

CABLE CHAIN SCHMABLE CHAIN

Attach the bottom of the cable chain before inserting the deck panel. Attempting to do it afterwards will activate hard mode for the build.

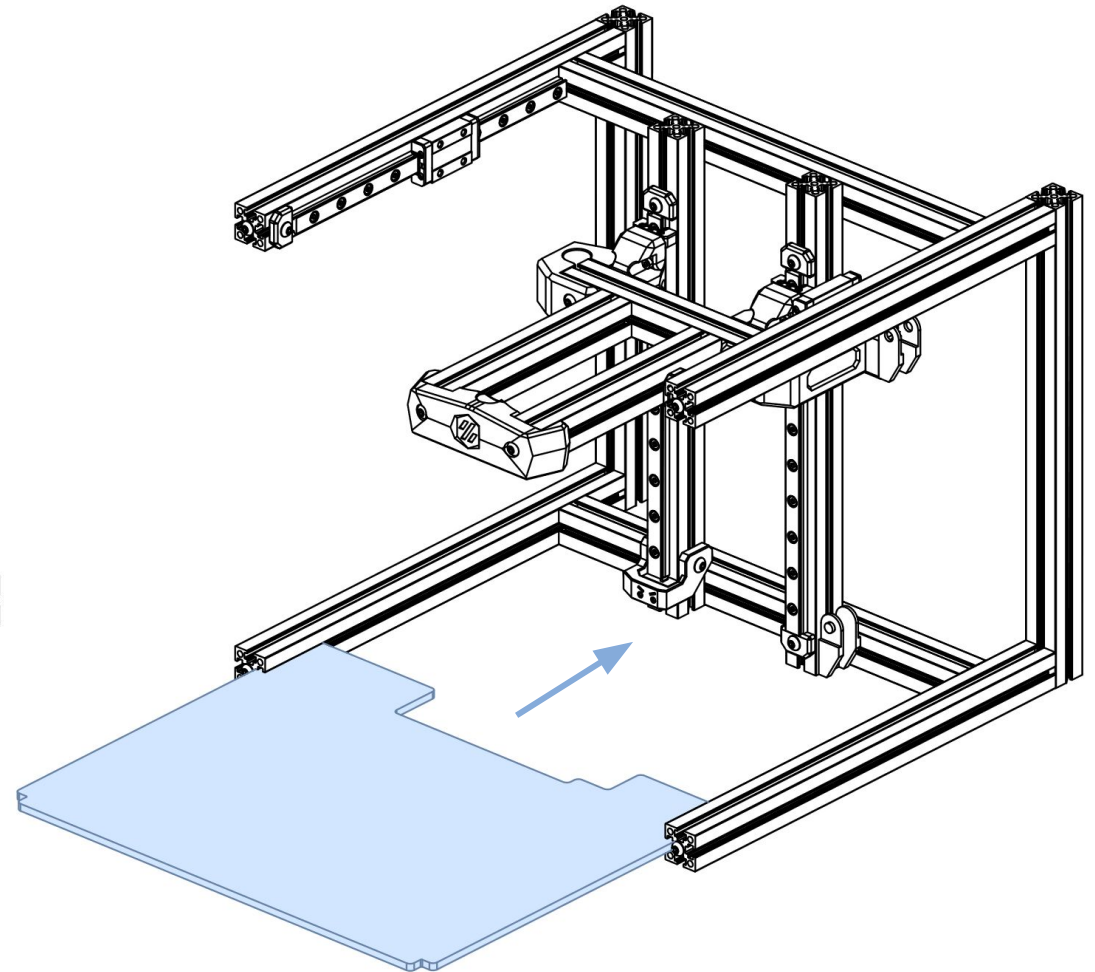

INSTALL THE DECK PANEL

The deck panel sits in the extrusion slots. Make sure it goes under the z endstop mount when installed.

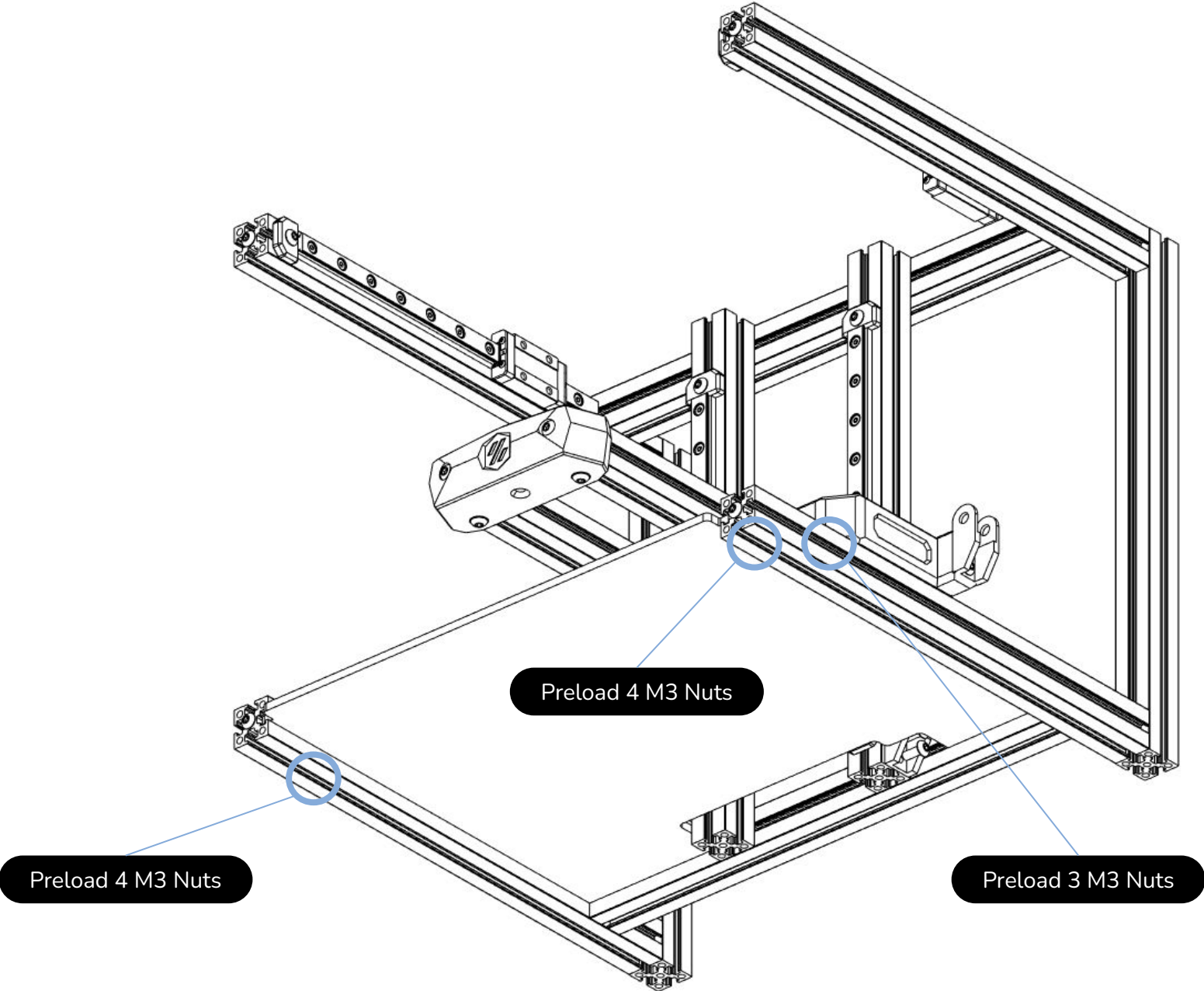

PRELOADING MORE NUTS

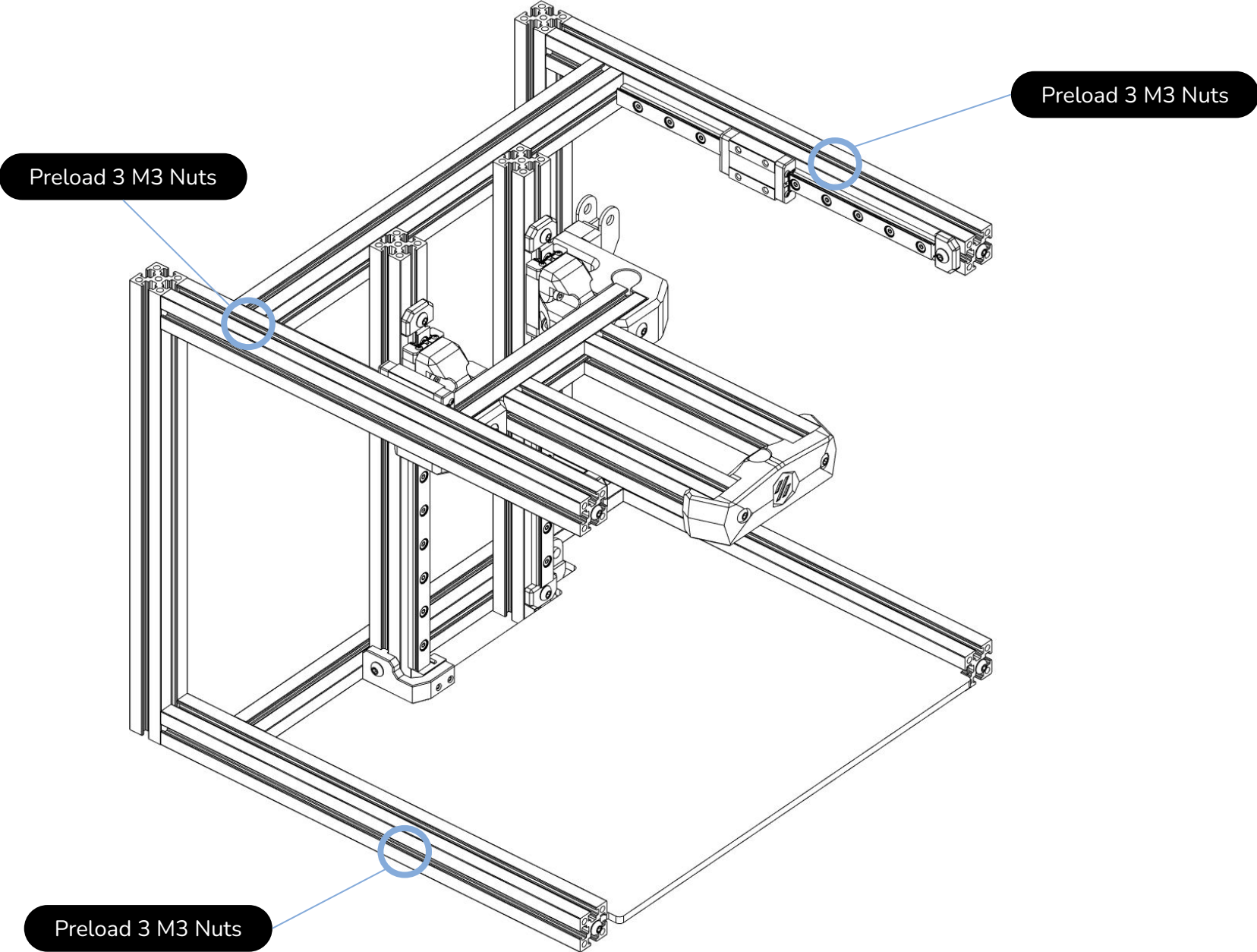

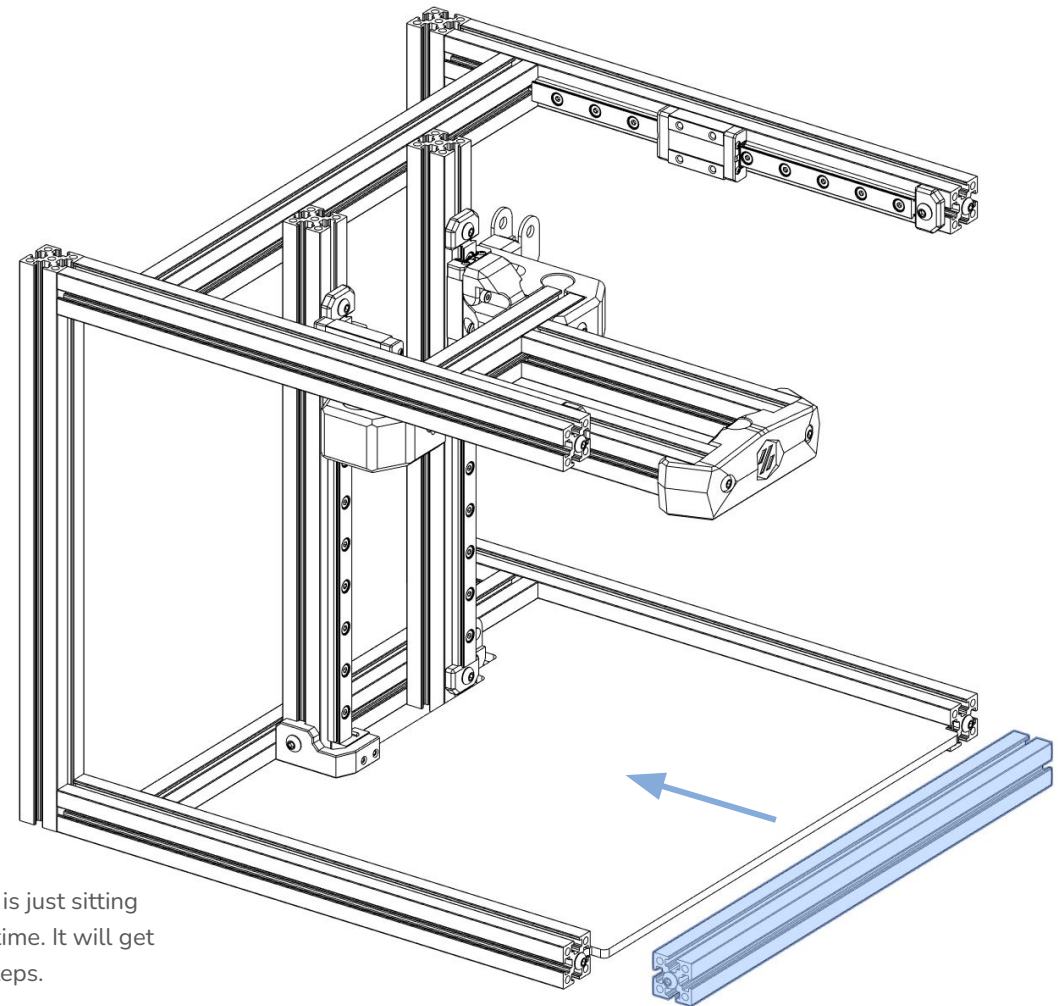
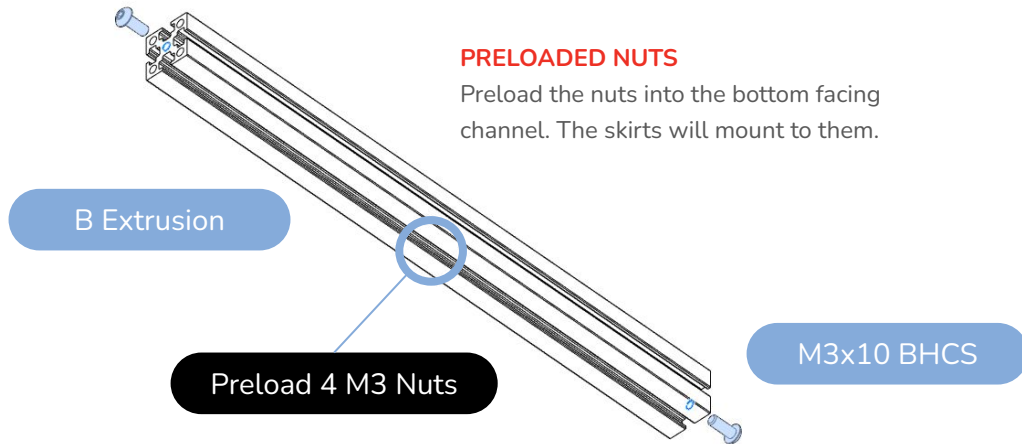

**LAST CHANCE!**

In the next few steps we will install the front extrusions, and in doing so we will be closing off the ends of the frame extrusions. This is the last chance to install preloaded M3 nuts into this portion of the frame, so pay special attention to the nut-checks on the next pages to make sure you have the correct number of M3 nuts in each extrusion slot.

Do not disappoint us.

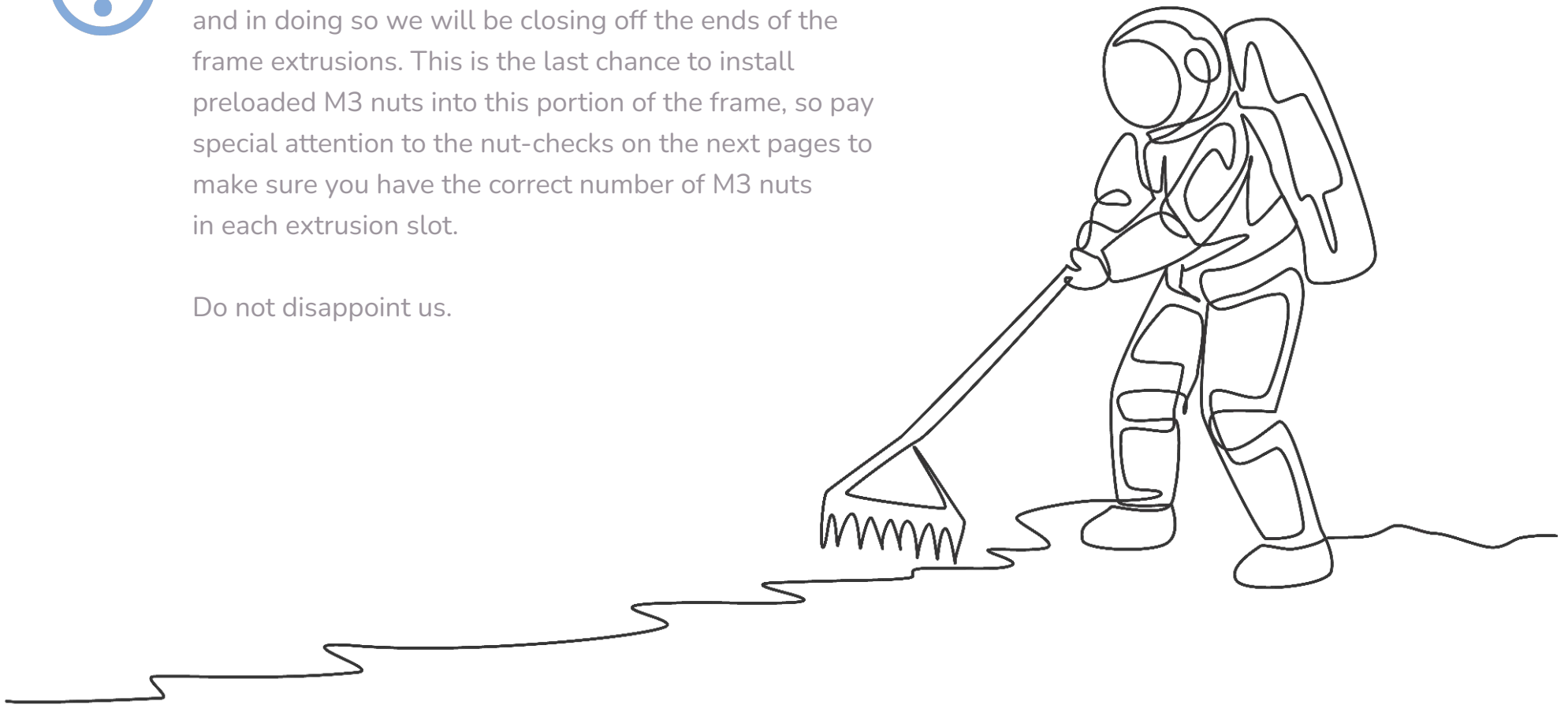

BOTTOM

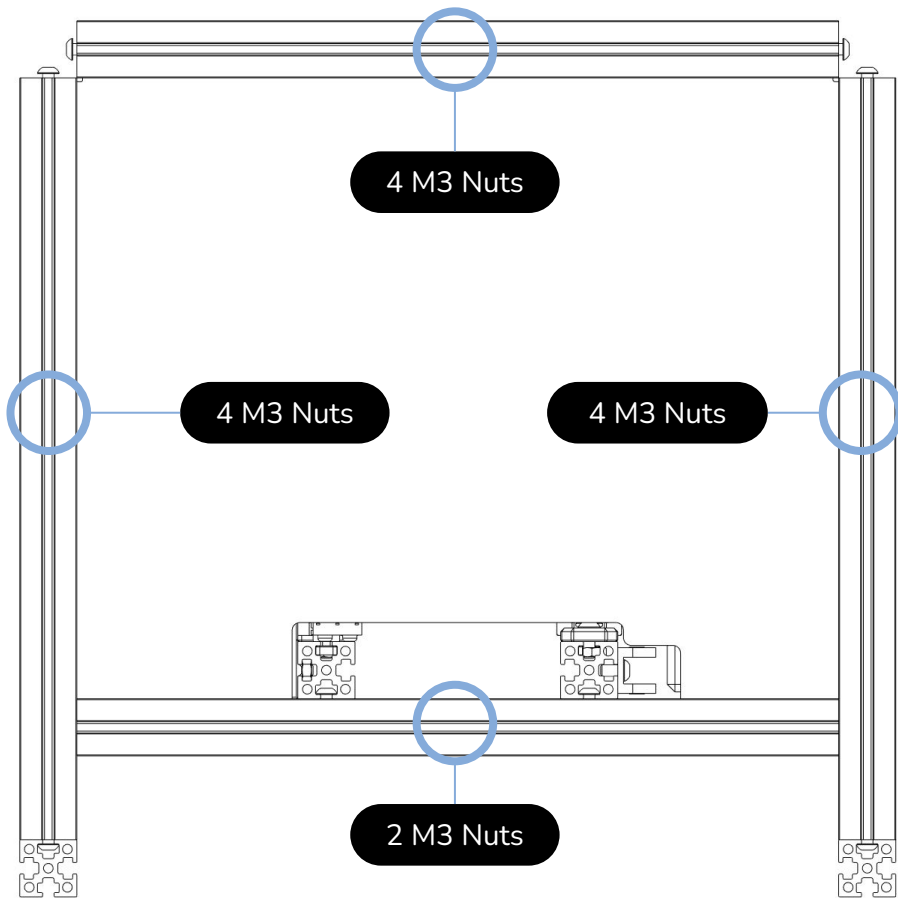

TOP

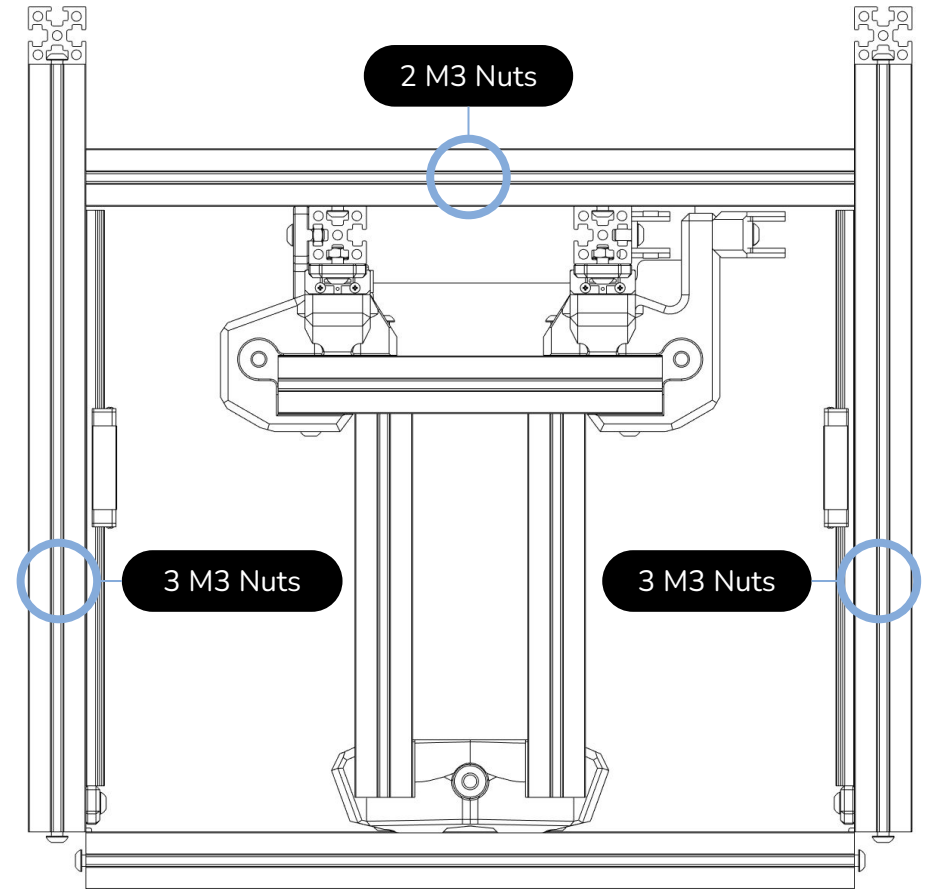

LEFT

RIGHT

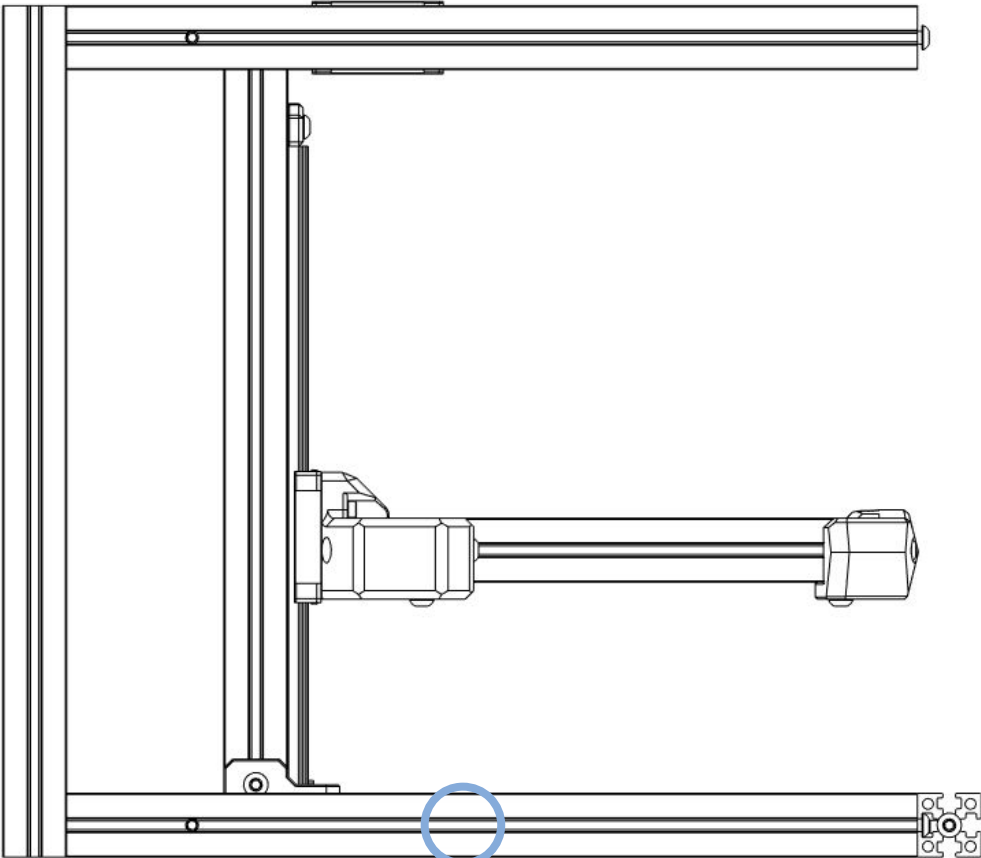

3 M3 Nuts

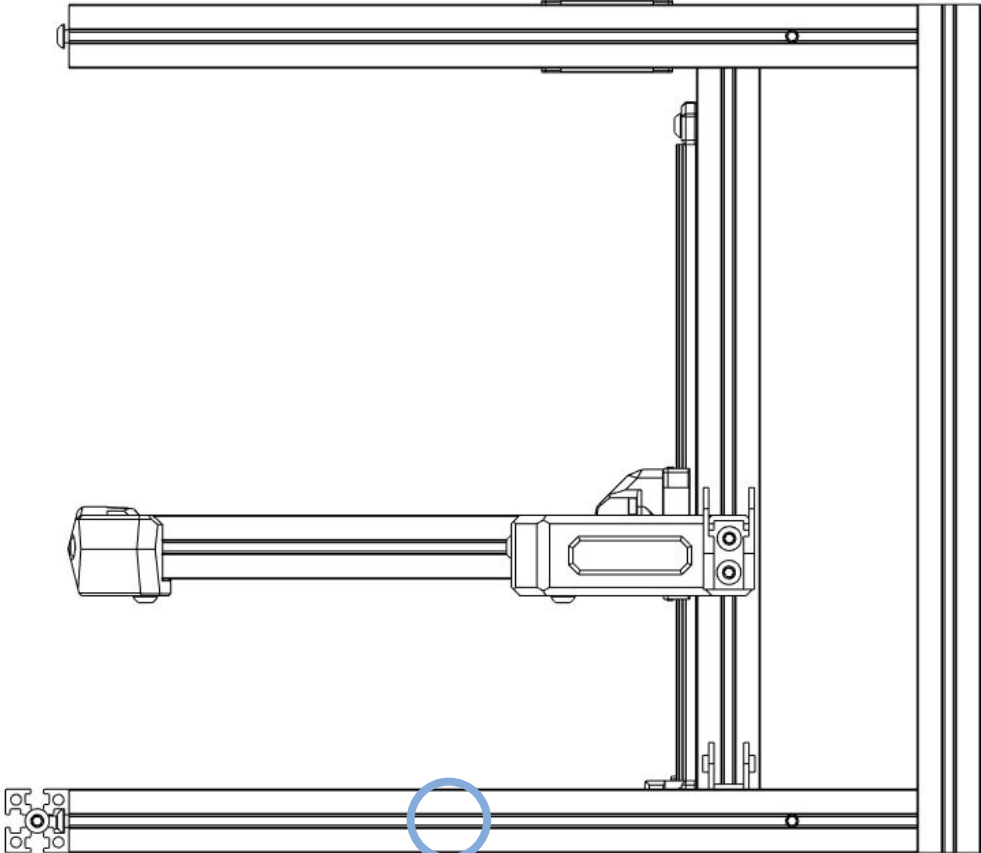

3 M3 Nuts

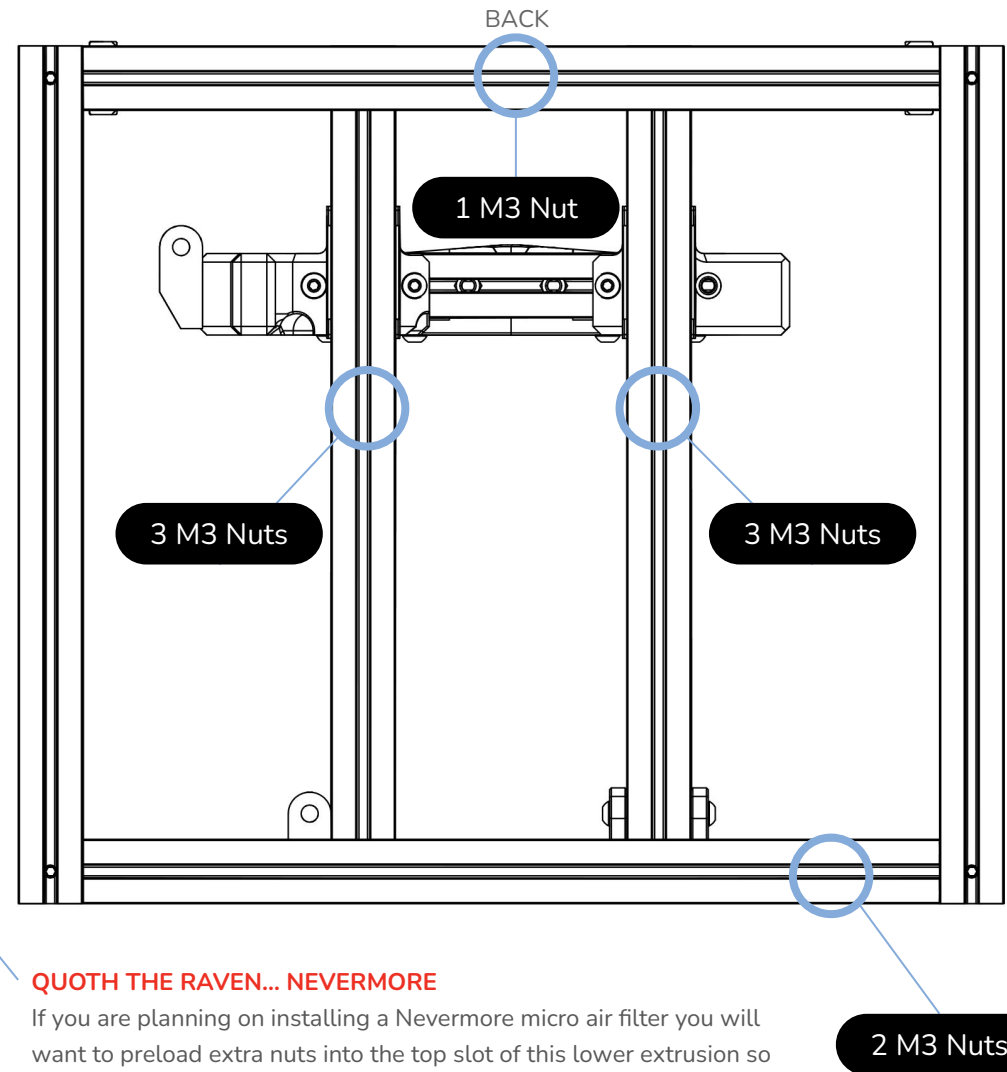
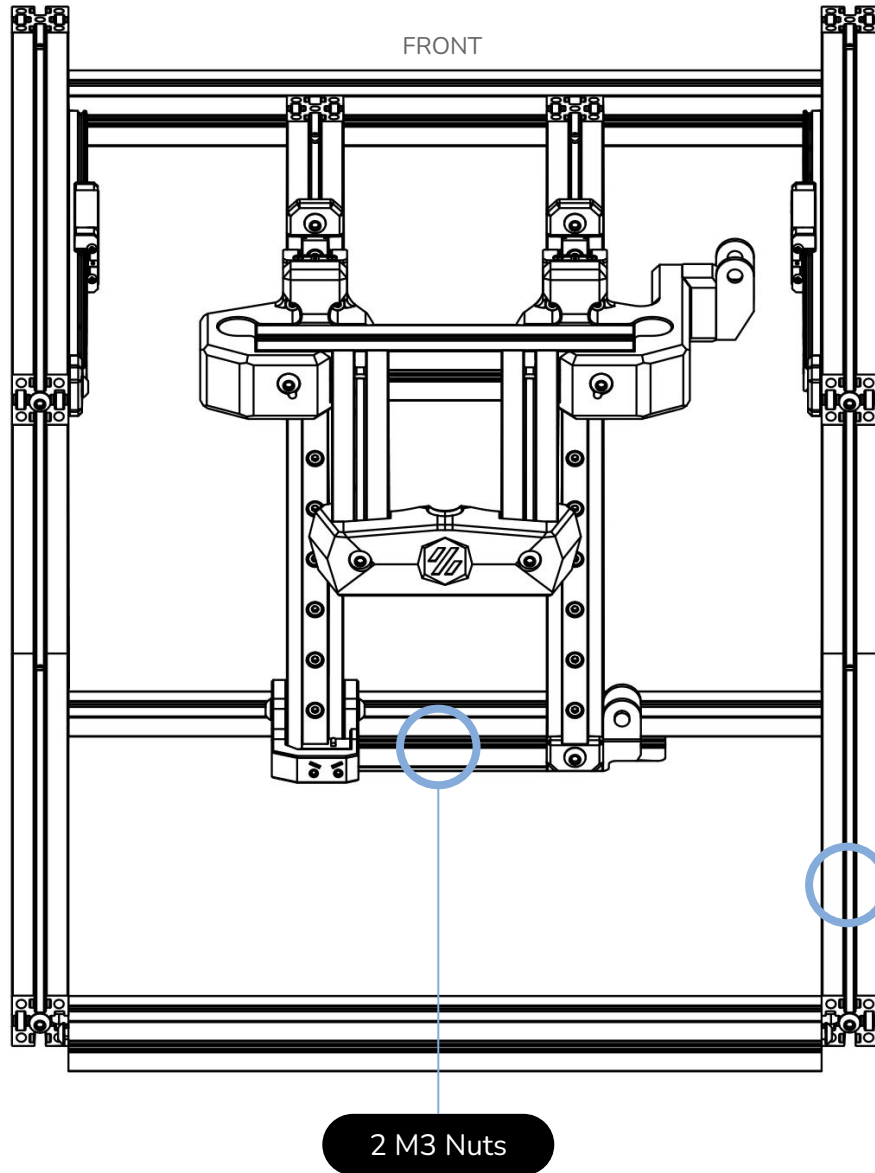

QUOTH THE RAVEN... NEVERMORE

If you are planning on installing a Nevermore micro air filter you will want to preload extra nuts into the top slot of this lower extrusion so that it can be mounted later. Refer to the nevermore documentation for the correct number of fasteners needed for your filter.

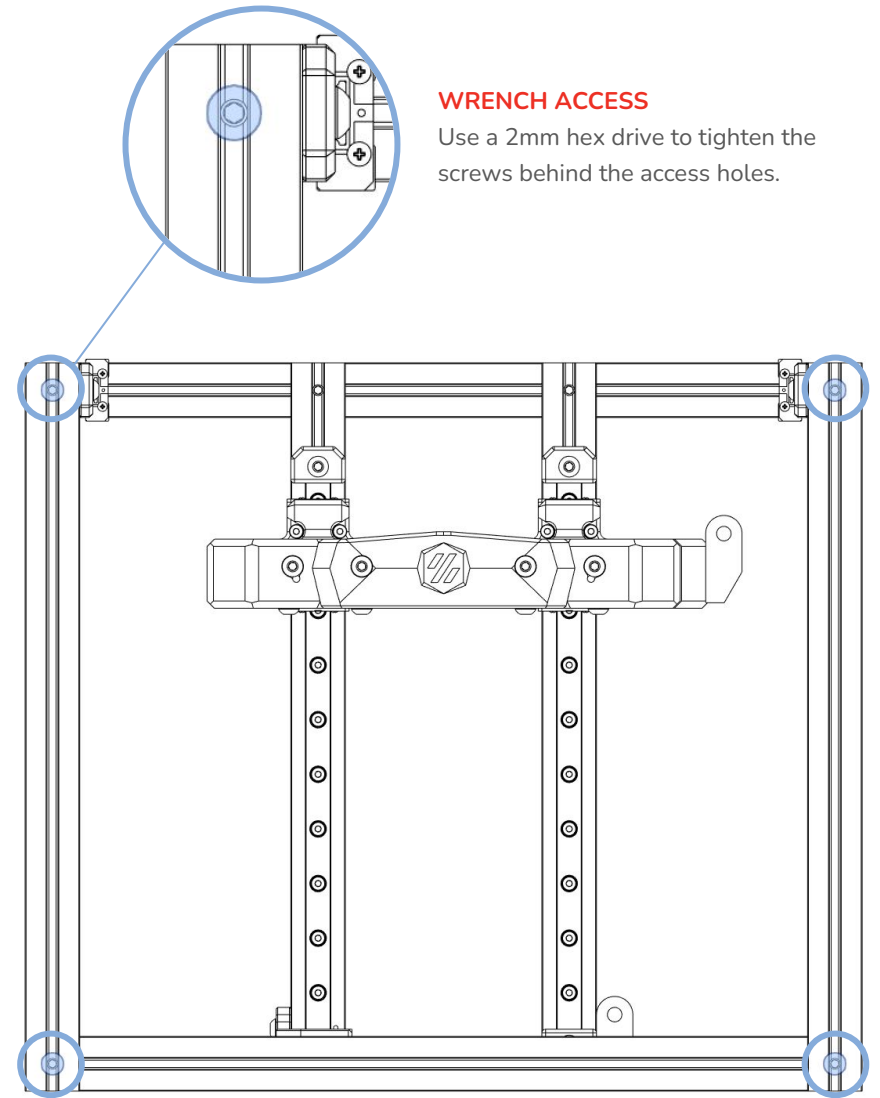
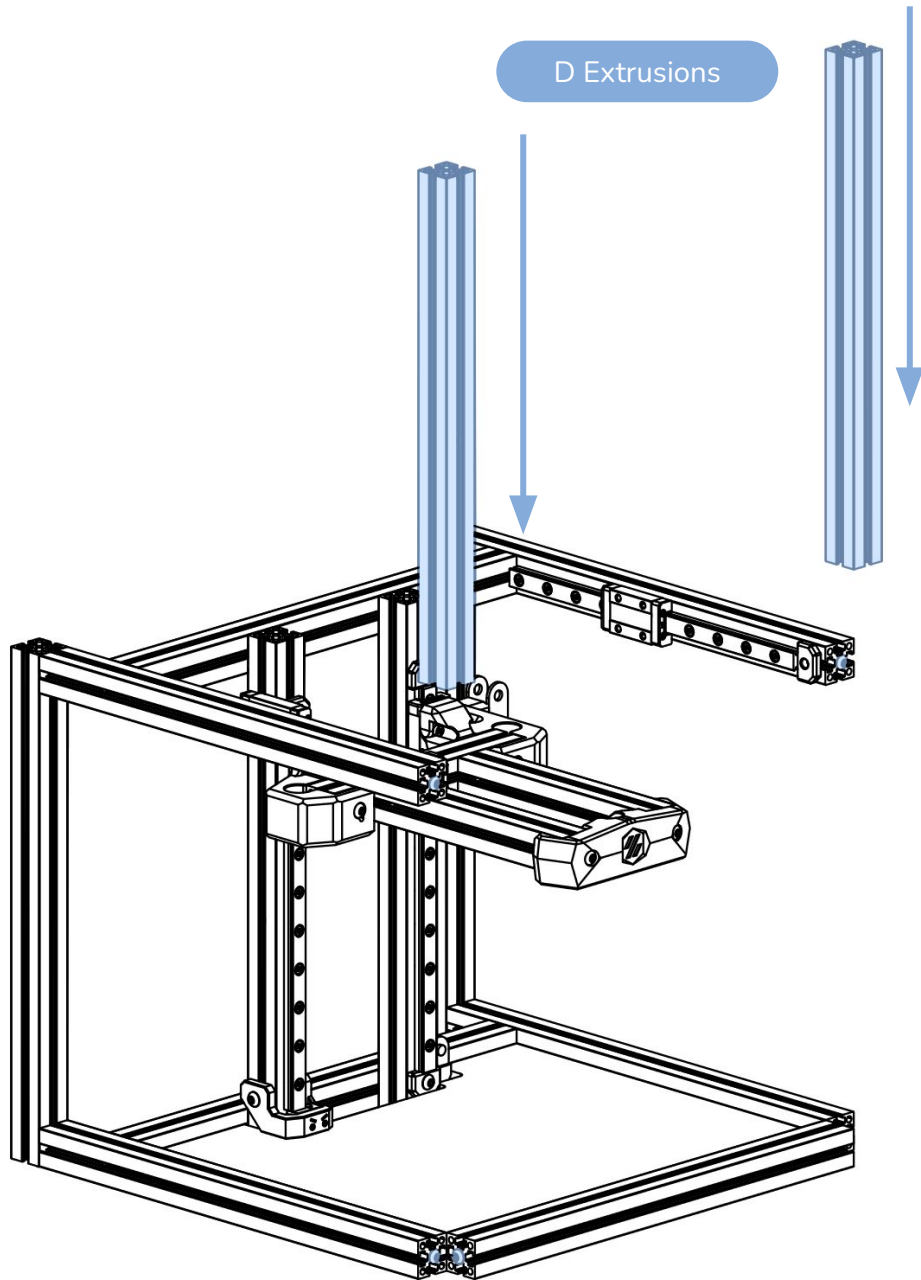

A MOMENT FOR MINDFULNESS

Now that you've got the base frame assembled, why not take a moment to step away, stretch, and have a sip of your beverage of choice.

This might also be a good chance to tidy up your work area a bit. Clean up any errant hardware and recollect your tools to be prepared for the rest of the build.

Or, you know, just keep building I guess.

You monster.





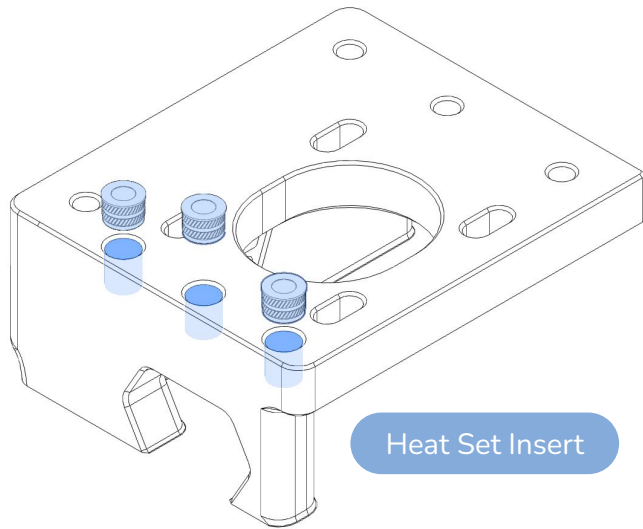

Heat Set Insert

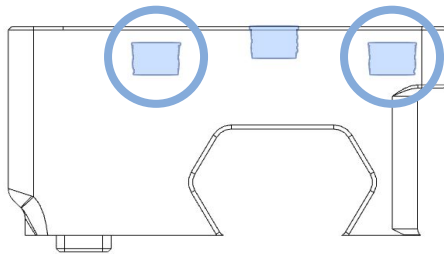

INSERTS SIT BELOW THE SURFACE

The outer heat set inserts sit below the surface of the part. When installing, make sure the heat set inserts bottom out in their hole.

IDENTIFYING THE CORRECT PARTS

The parts have their sides embossed.

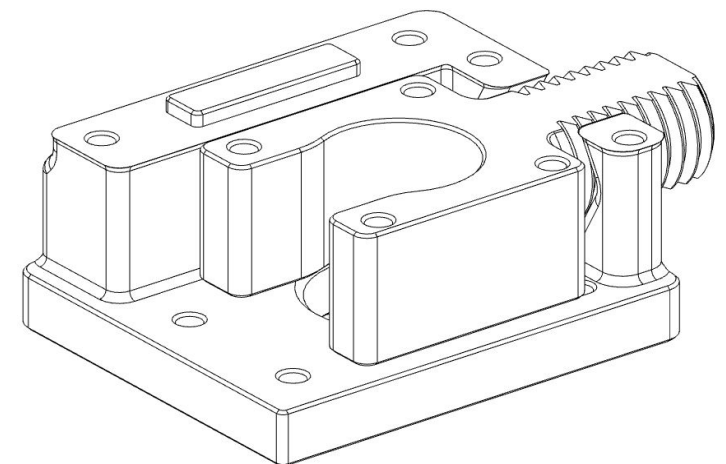
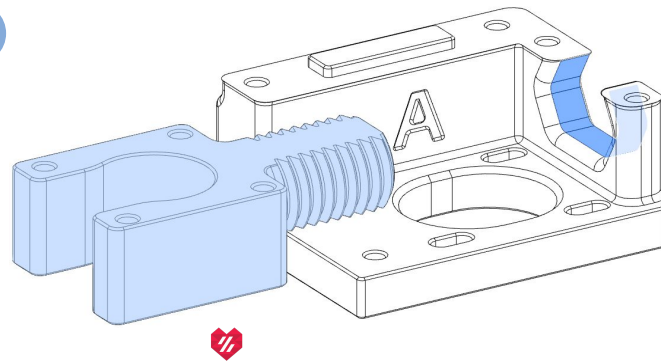
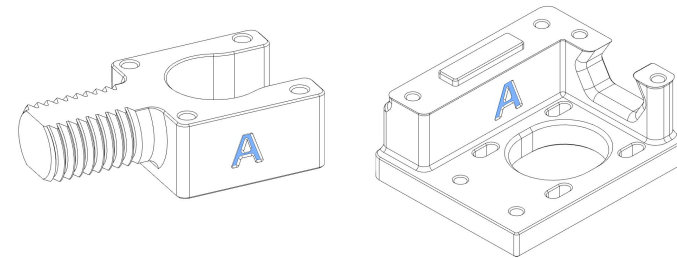

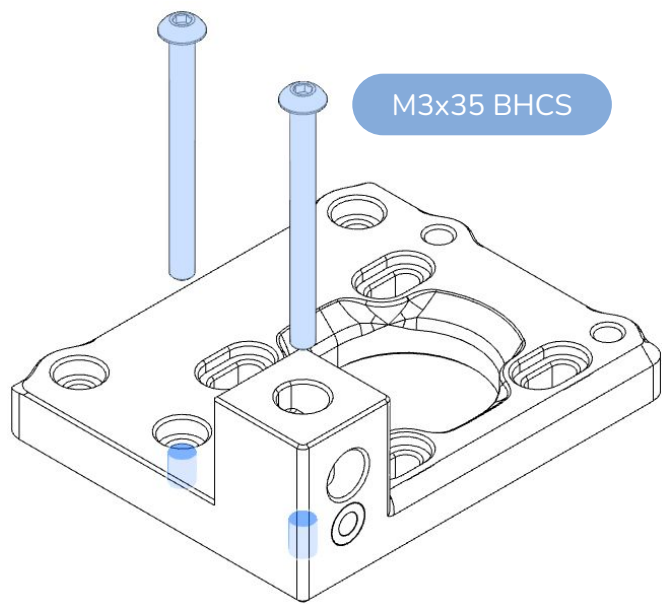
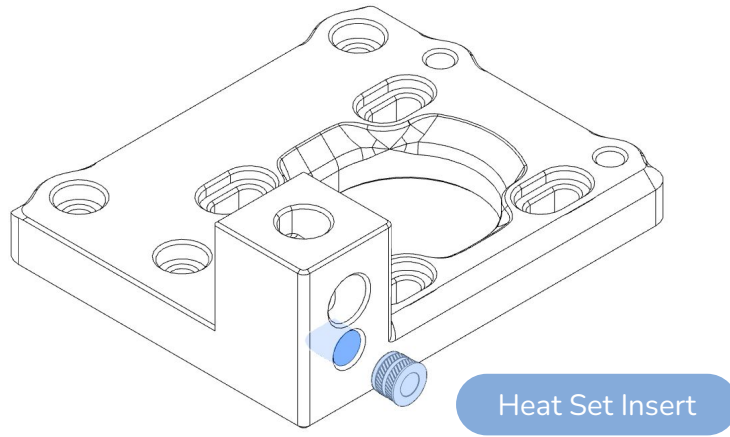

A NOTE ON SHIMS

We specify shims as they have a consistent thickness compared to regular washers. If you sourced washers instead make sure to measure their thickness (target = 0.5mm) to avoid issues with the stackup.

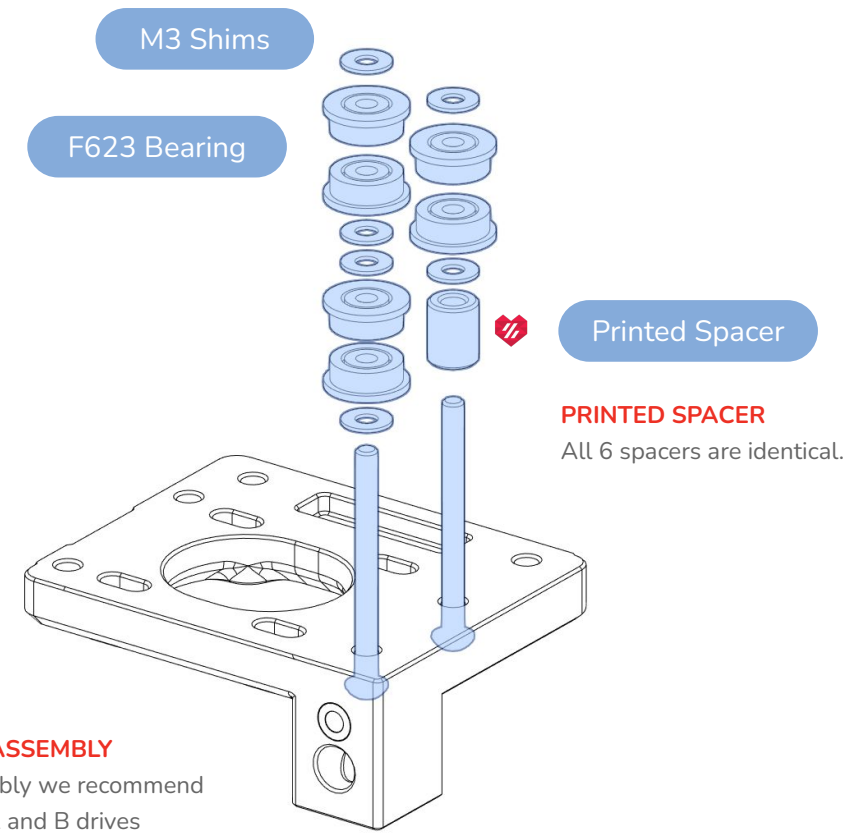

UPSIDE DOWN ASSEMBLY

For ease of assembly we recommend to assemble the A and B drives upside down.

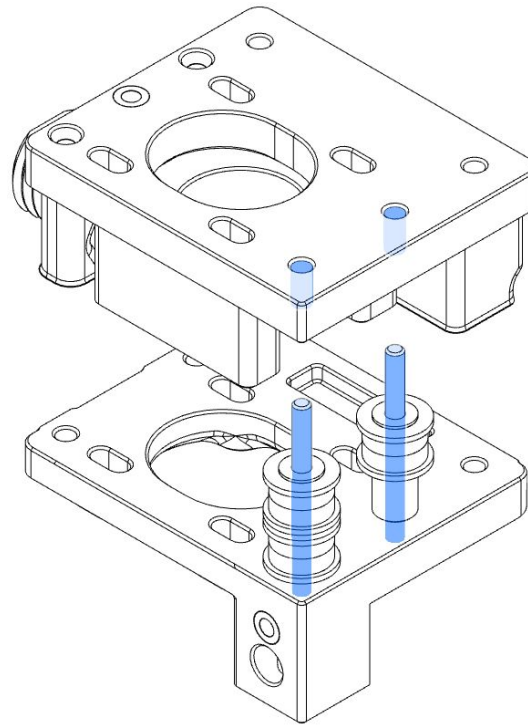
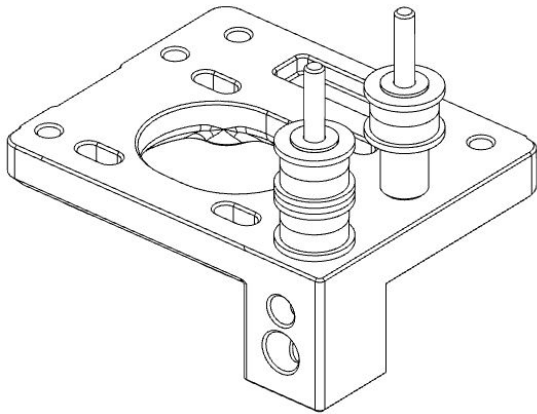

THANKS A LOT NEWTON

On the next page we are going to flip this assembly over. Adding temporary nuts to these two M3x35 screws can prevent gravity from playing cruel tricks on you.

FINAL STACK HEIGHT

Tolerance stackup can cause issues. The total height of the bearing stacks should be 18mm.

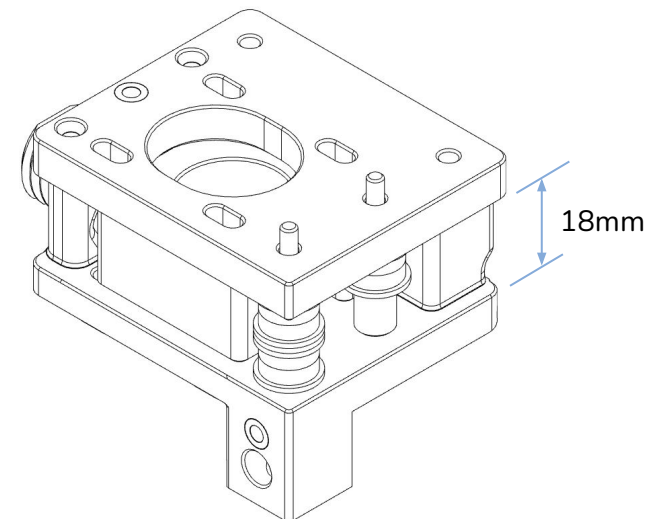

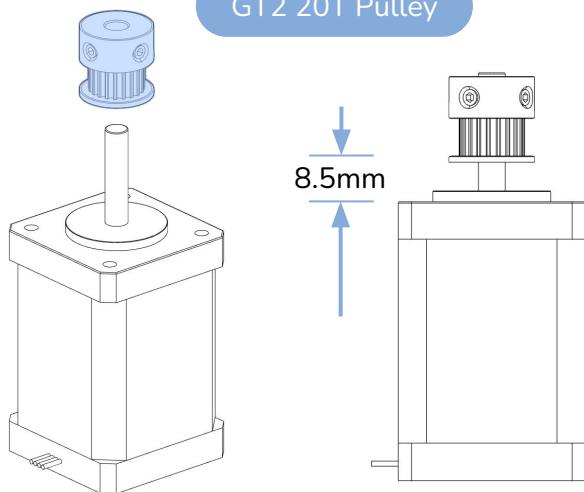
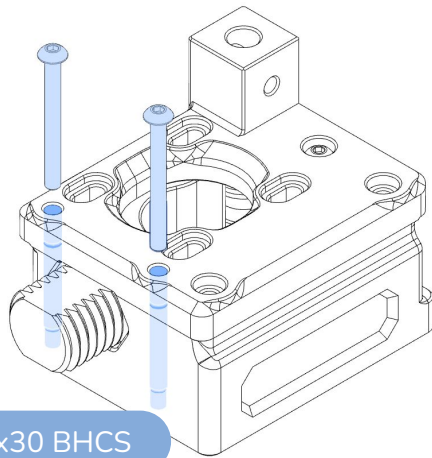

NEMA14 Stepper

IRISH JIG

No, its plastic, but you can use it to help set the pulley height.

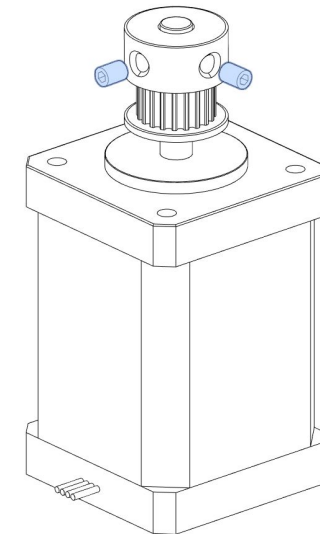
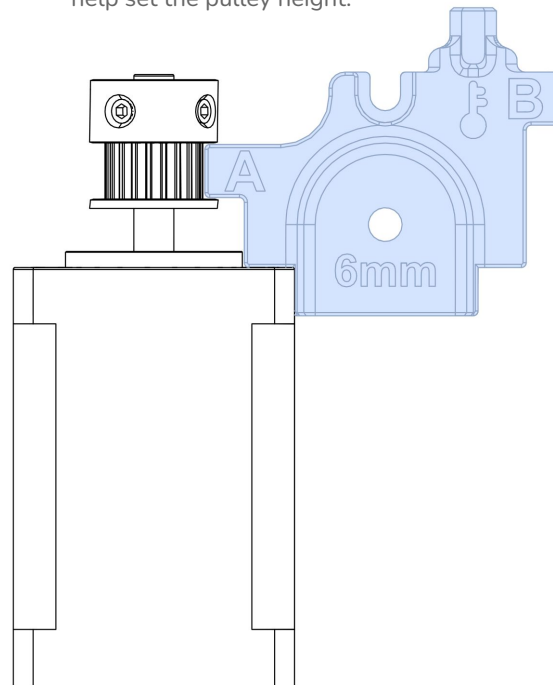

GRUB SCREWS

AKA THE ROOT OF ALL ISSUES

Use thread locker on all grub screws.

Loose grub screws account for a large percentage of issues that our users report. Save yourself hours of troubleshooting and apply threadlocker to all grub screws during the build. See the instructions on your threadlocker product.

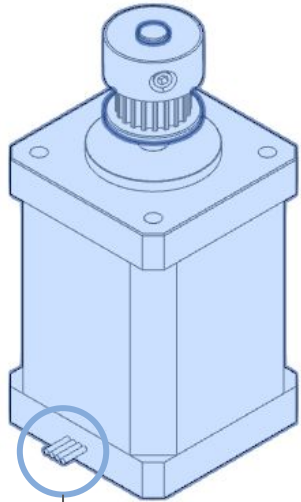
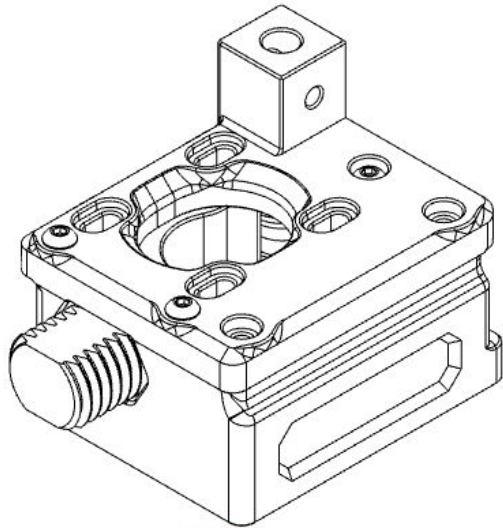

M3x35 BHCS

M3 Washer

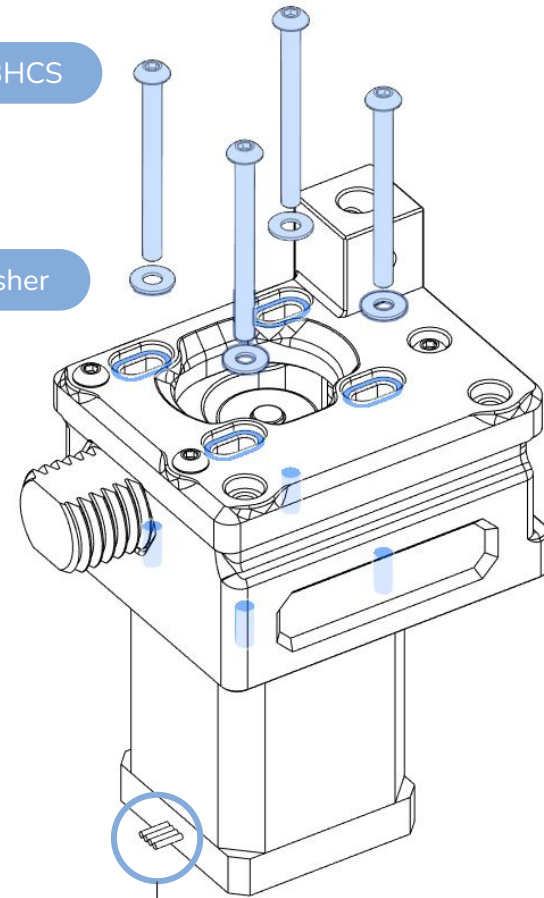

MOTOR WIRE DIRECTION

Take note of the direction that the motor wires are facing. Pointing inward will give adequate clearance for the wiring.

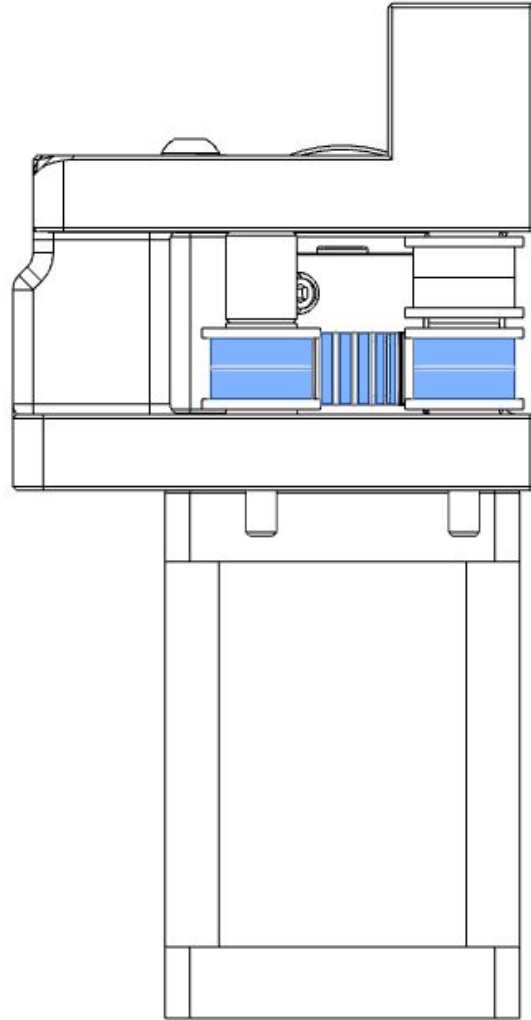
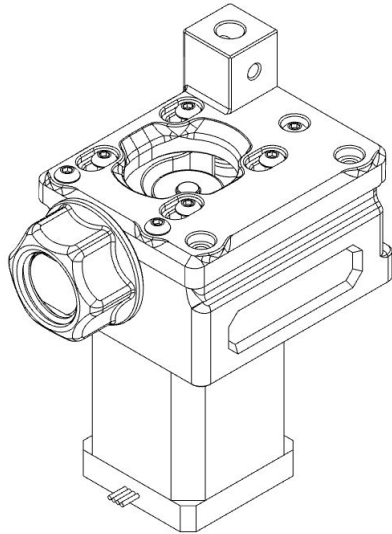
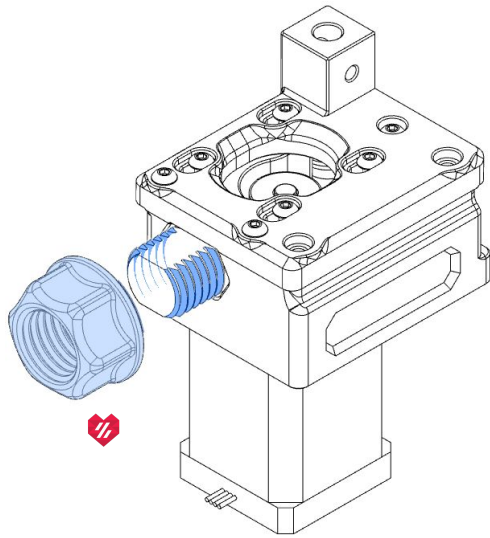

CHECK YOUR WORK

Compare your assembled parts to the graphic shown here. Pay attention to the pulley orientation and alignment with the bearing stack ups.

If needed, loosen the grub screws and adjust the pulley height so that the teeth are centered with the bearing races.

Heat Set Insert

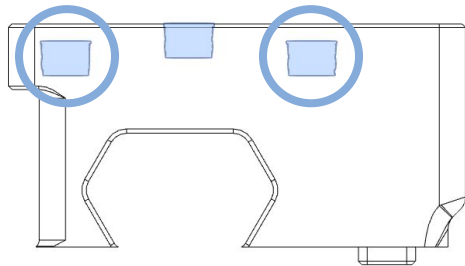
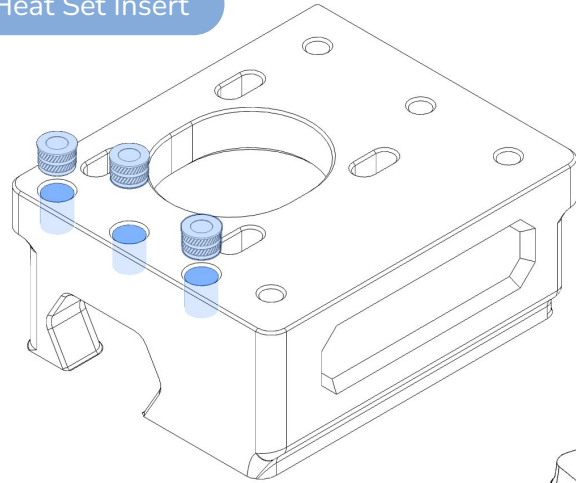

INSERTS SIT BELOW THE SURFACE

The outer heat set inserts sit below the surface of the part. When installing, make sure the heat set inserts bottom out in their hole.

DEJA VU?

We will repeat the drive assembly steps for the B drive unit.

IDENTIFYING THE CORRECT PARTS

The parts have their sides embossed.

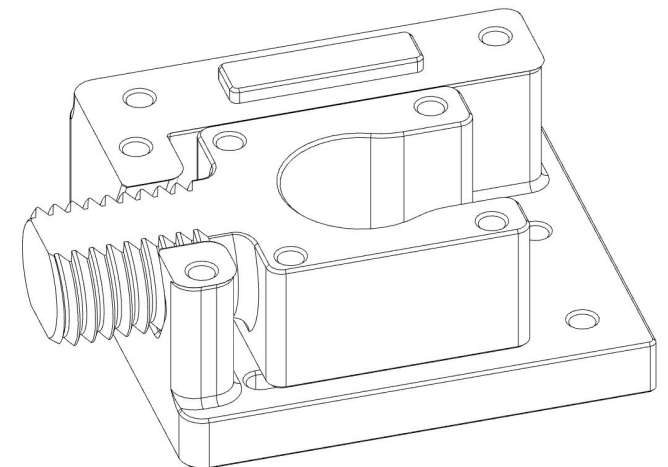
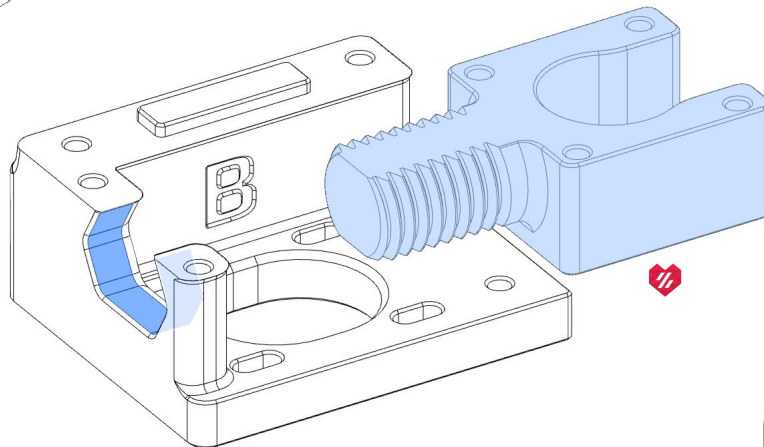
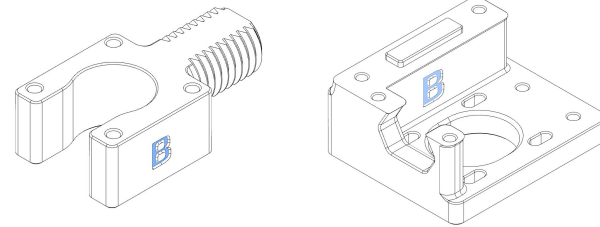

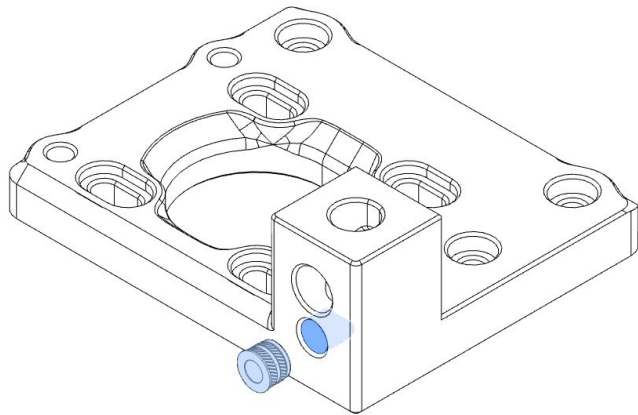

Heat Set Insert

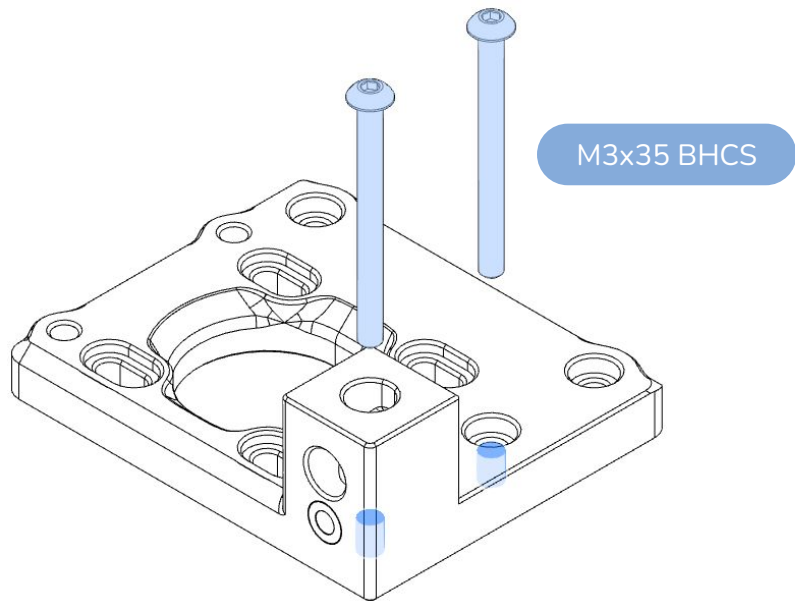

M3x35 BHCS

A NOTE ON SHIMS

We specify shims as they have a consistent thickness compared to regular washers. If you sourced washers instead make sure to measure their thickness (target = 0.5mm) to avoid issues with the stackup.

Printed Spacer

PRINTED SPACER
All 6 spacers are identical.



M3 Shims

F623 Bearing

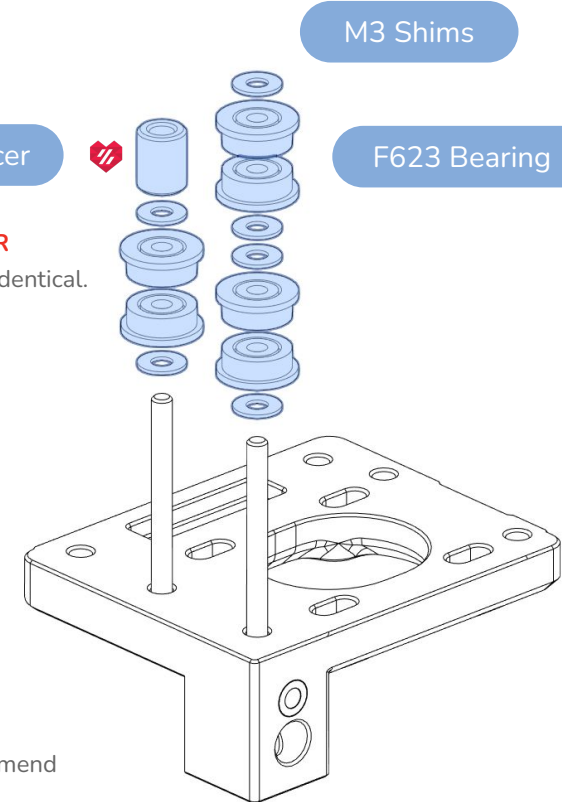

UPSIDE DOWN ASSEMBLY

For ease of assembly we recommend to assemble the A and B drives upside down.

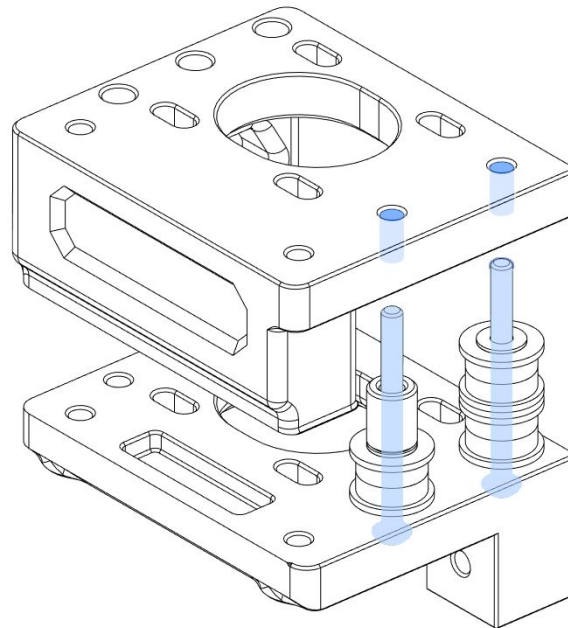
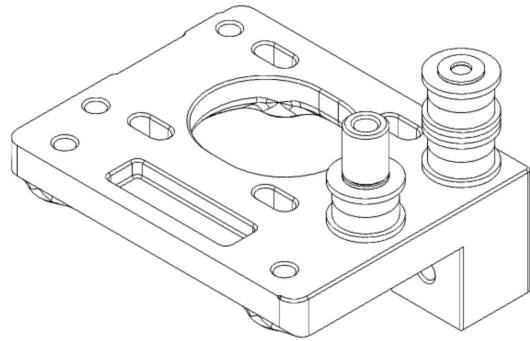

FINAL STACK HEIGHT

Tolerance stackup can cause issues. The total height of the bearing stacks should be 18mm.

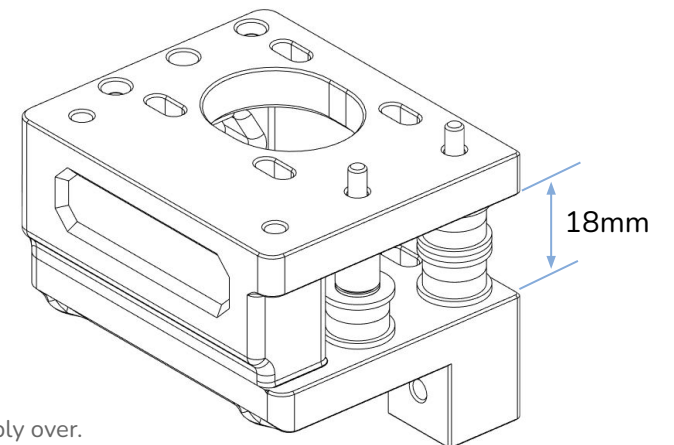

THANKS A LOT NEWTON

On the next page we are going to flip this assembly over. Adding temporary nuts to these two M3x35 screws can prevent gravity from playing cruel tricks on you.

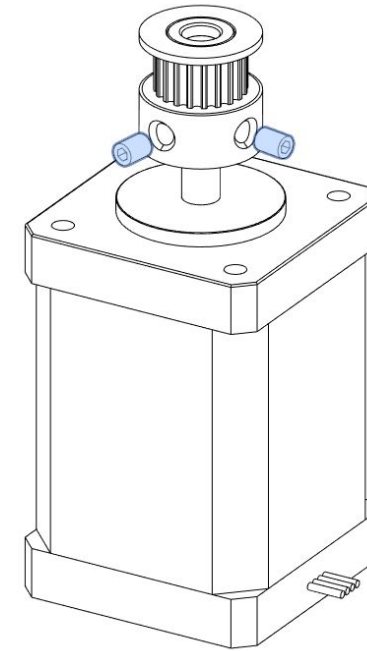
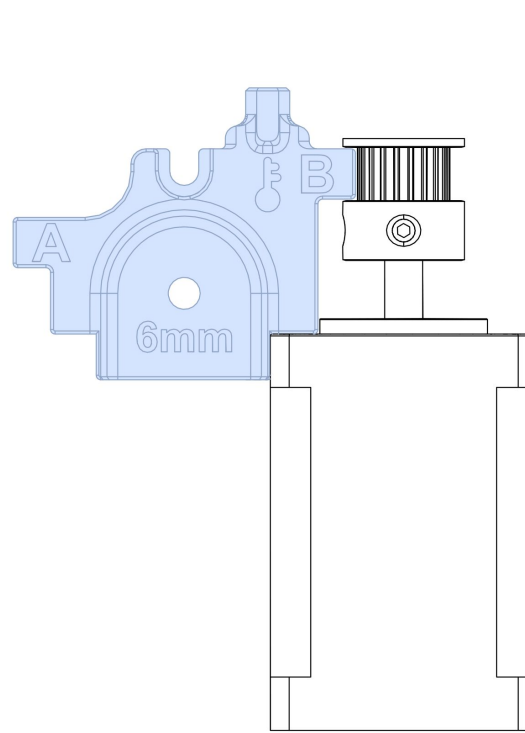
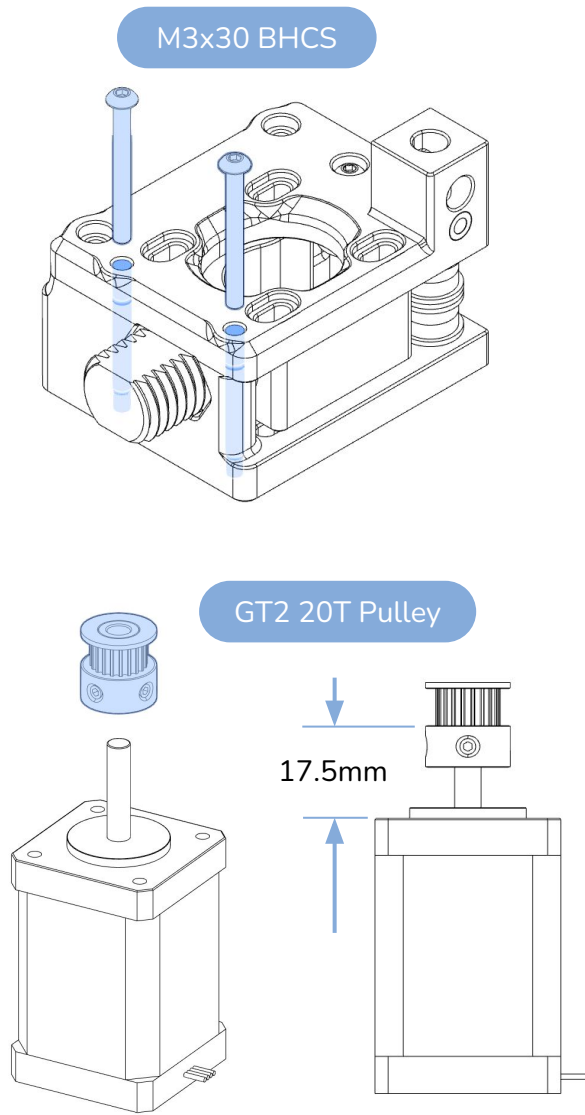

GRUB SCREWS

AKA THE ROOT OF ALL ISSUES

Use thread locker on all grub screws.

Loose grub screws account for a large percentage of issues that our users report. Save yourself hours of troubleshooting and apply threadlocker to all grub screws during the build. See the instructions on your threadlocker product.

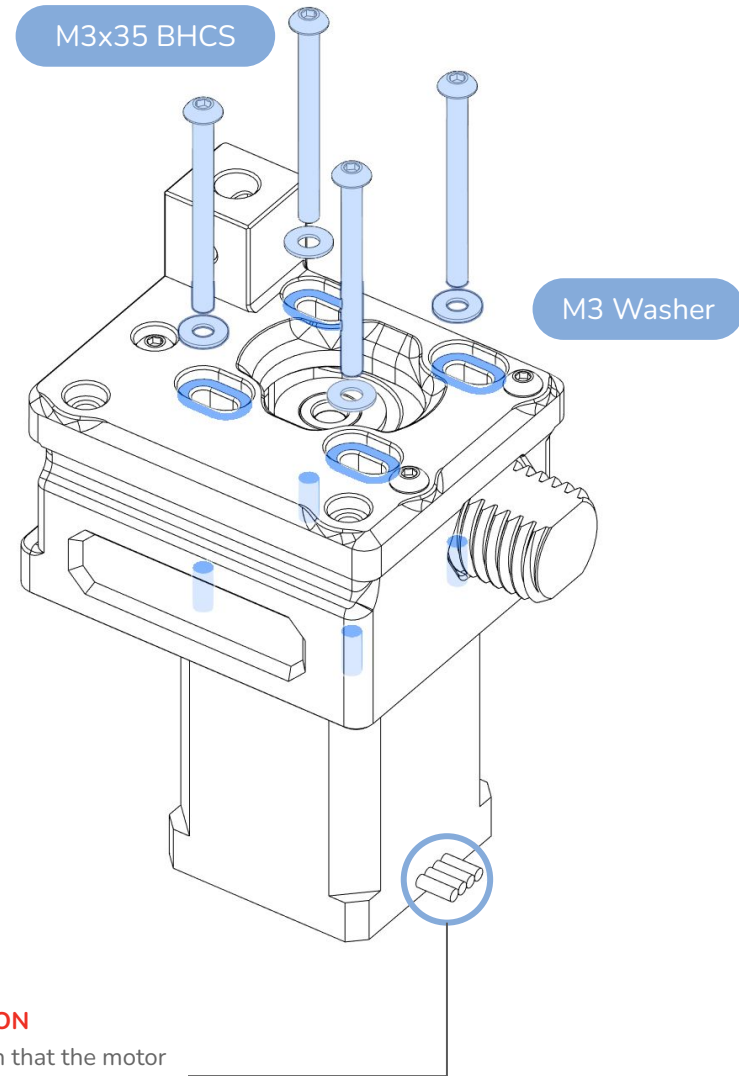
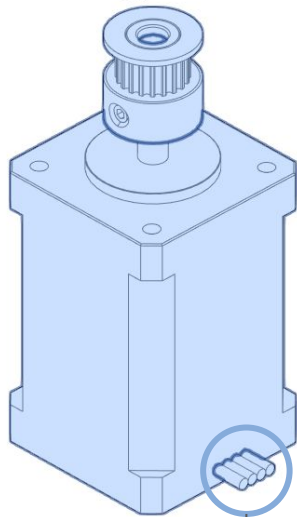
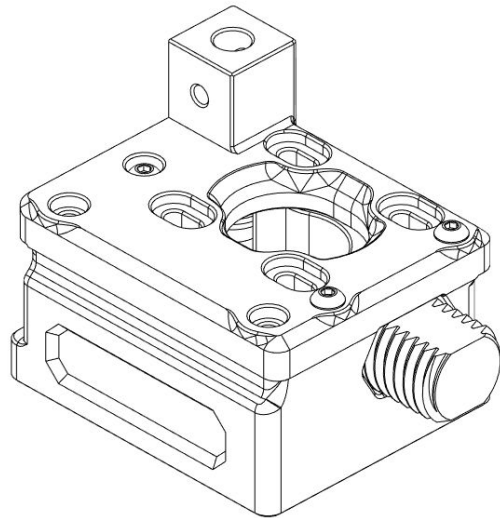

MOTOR WIRE DIRECTION

Take note of the direction that the motor wires are facing. Pointing inward will give adequate clearance for the wiring.

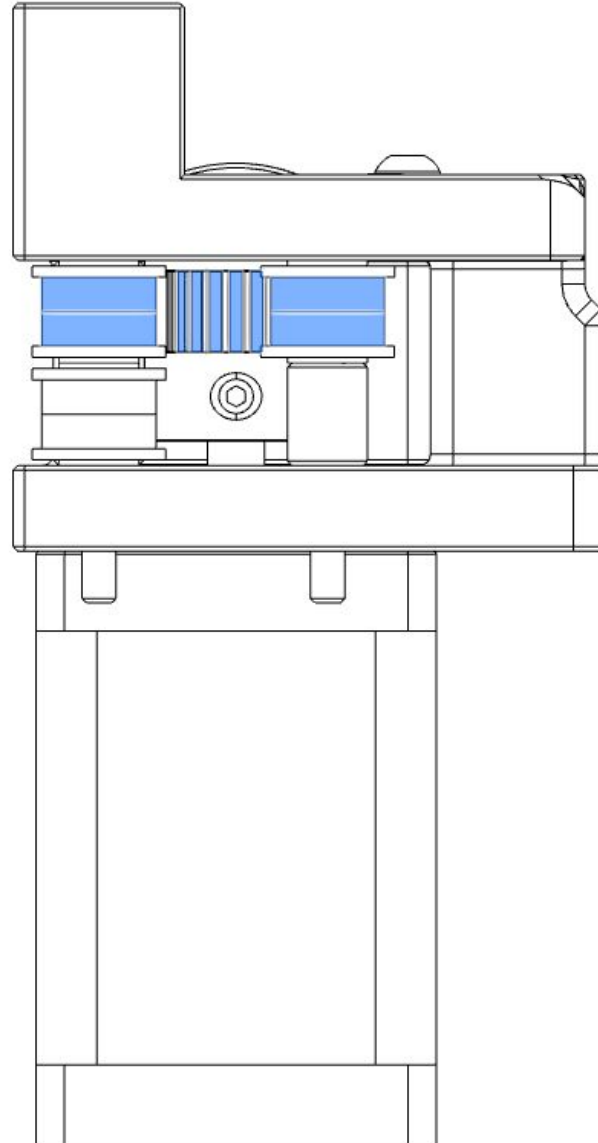
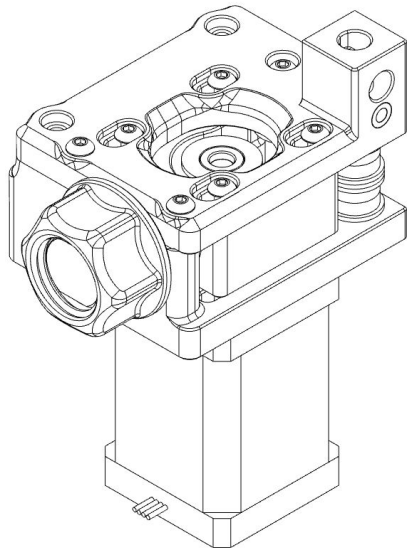
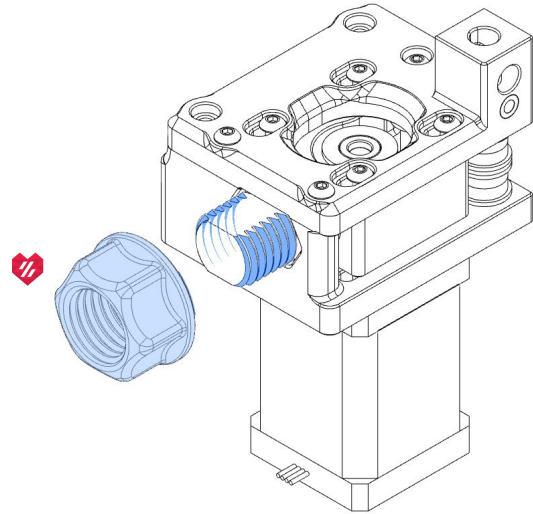

CHECK YOUR WORK

Compare your assembled parts to the graphic shown here. Pay attention to the pulley orientation and alignment with the bearing stack ups.

If needed, loosen the grub screws and adjust the pulley height so that the teeth are centered with the bearing races.

THE PRINTER GOES BA!...LIKE A SHEEP

The B drive goes on the left and the A drive goes on the right.

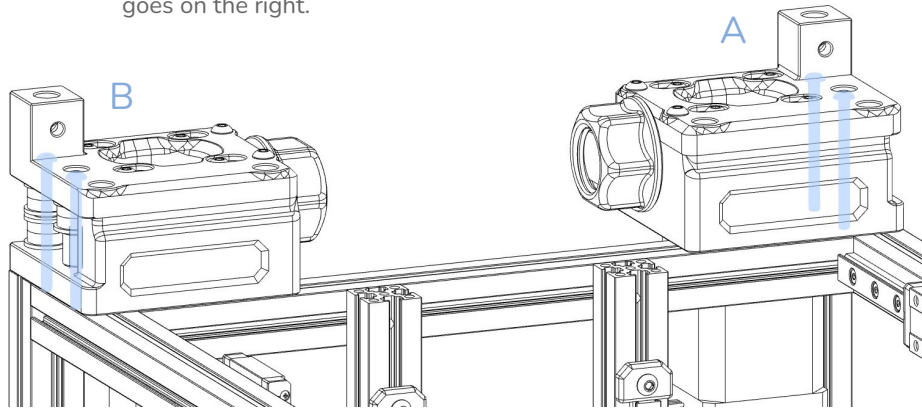

SECURE THE DRIVE UNITS

The two rear screws attach to the threaded frame ends, the two forward screws attach to preloaded nuts. Don't forget to remove the temporary m3 nuts if you installed them earlier.

PRELOADED NUTS

The screws are fastened into the preloaded nuts. Slide the nuts into position prior to placing the part.

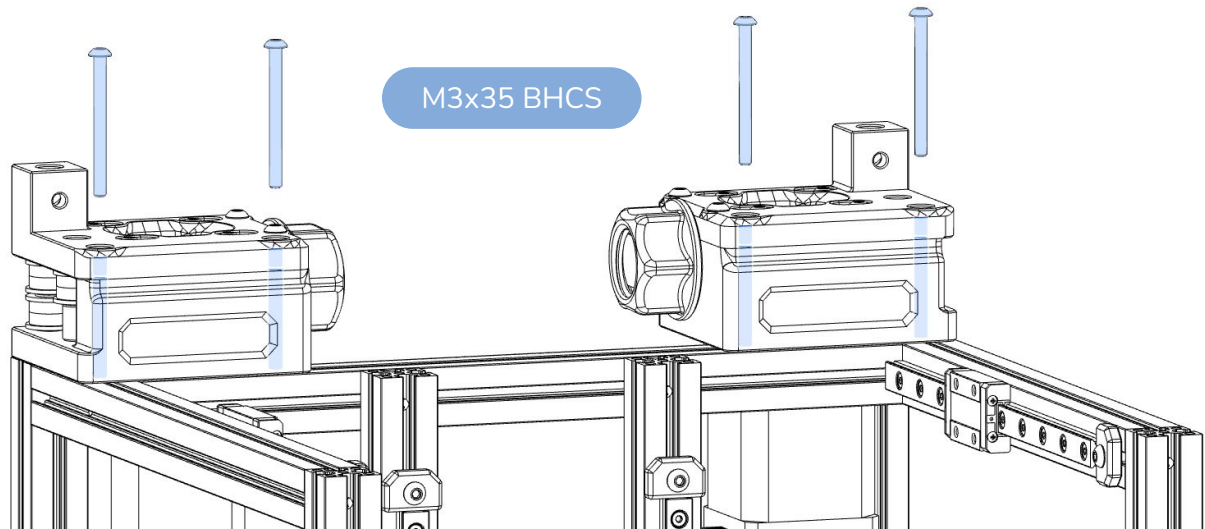



This isn't where I parked
my rover...



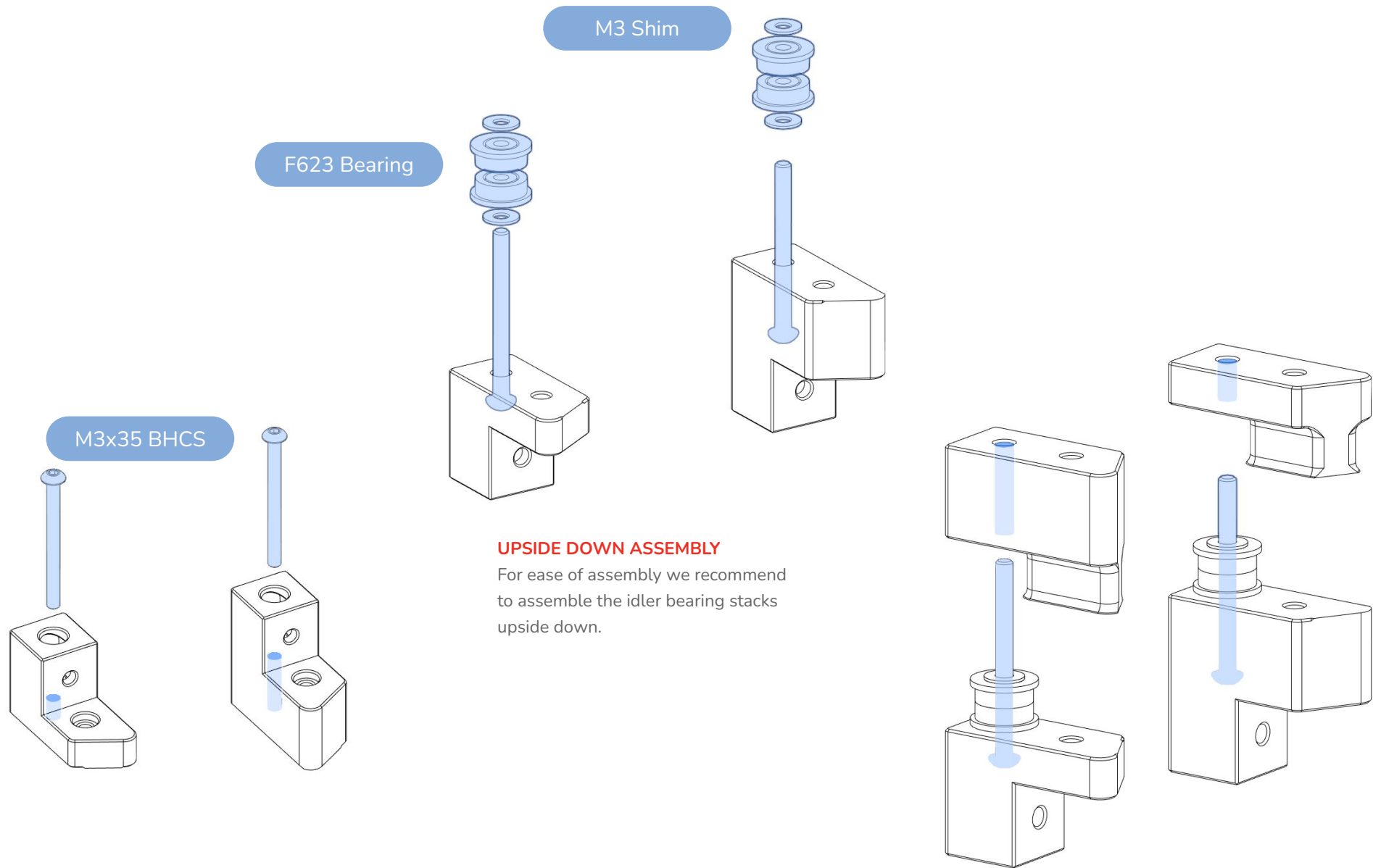

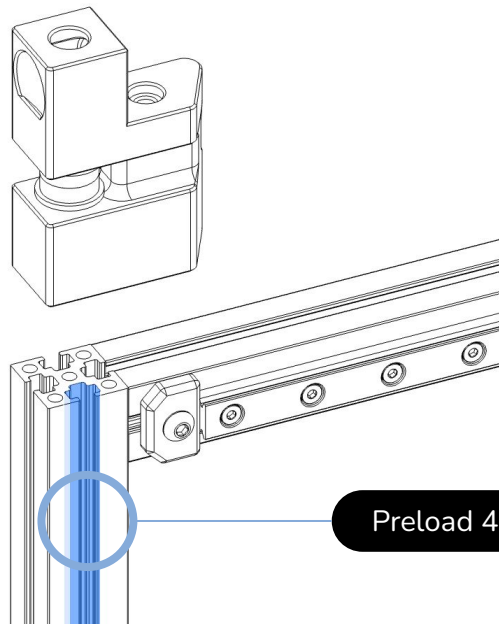

Preload 4 M3 Nuts

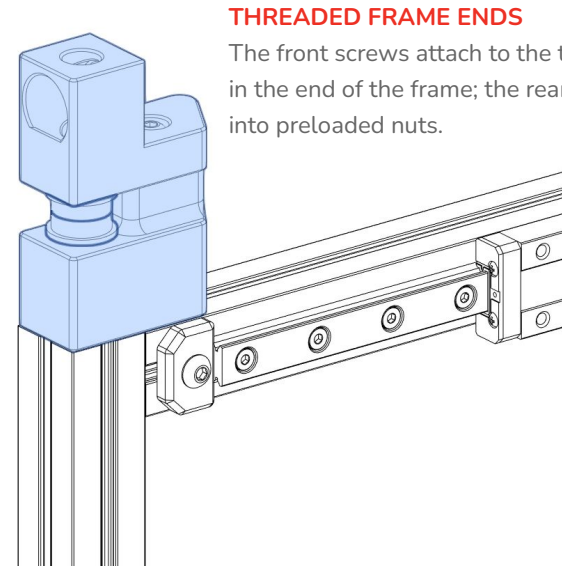

THREADED FRAME ENDS

The front screws attach to the threaded hole in the end of the frame; the rear screws go into preloaded nuts.

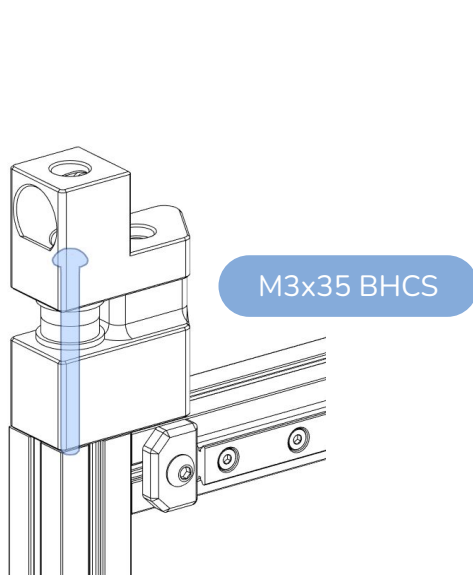

M3x35 BHCS

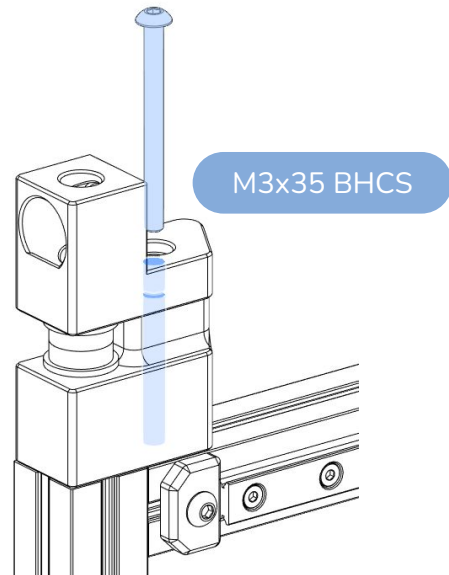

M3x35 BHCS

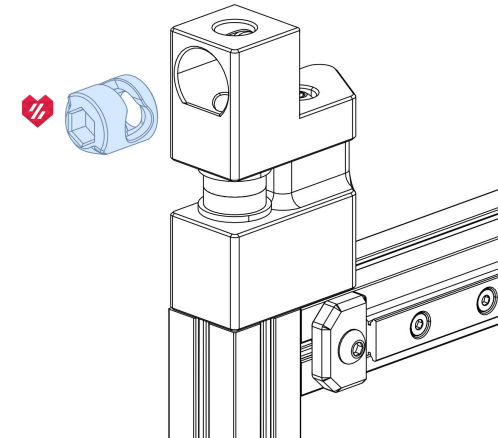

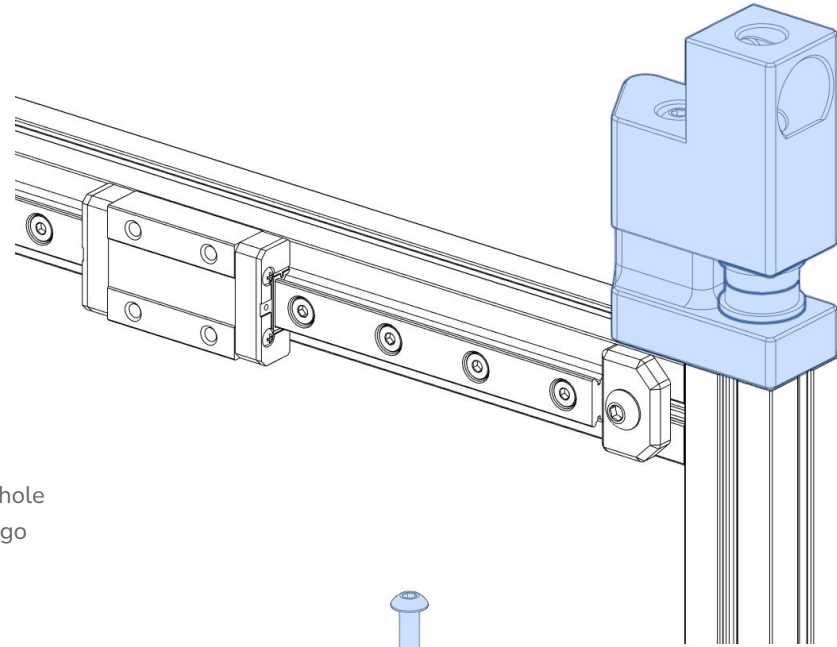

THREADED FRAME ENDS

The front screws attach to the threaded hole in the end of the frame. The rear screws go into preloaded nuts.

M3x35 BHCS

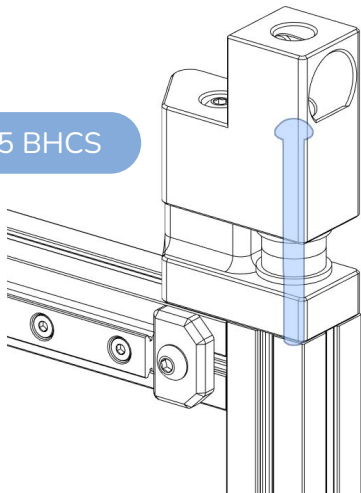

M3x35 BHCS

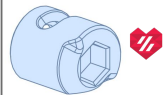
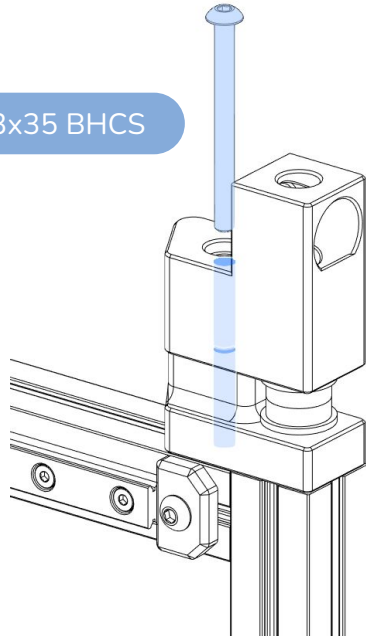

A IDLER

The A idler goes on the same side as the A Drive unit. The bearing stacks should be the same heights. It also has a taller top section.

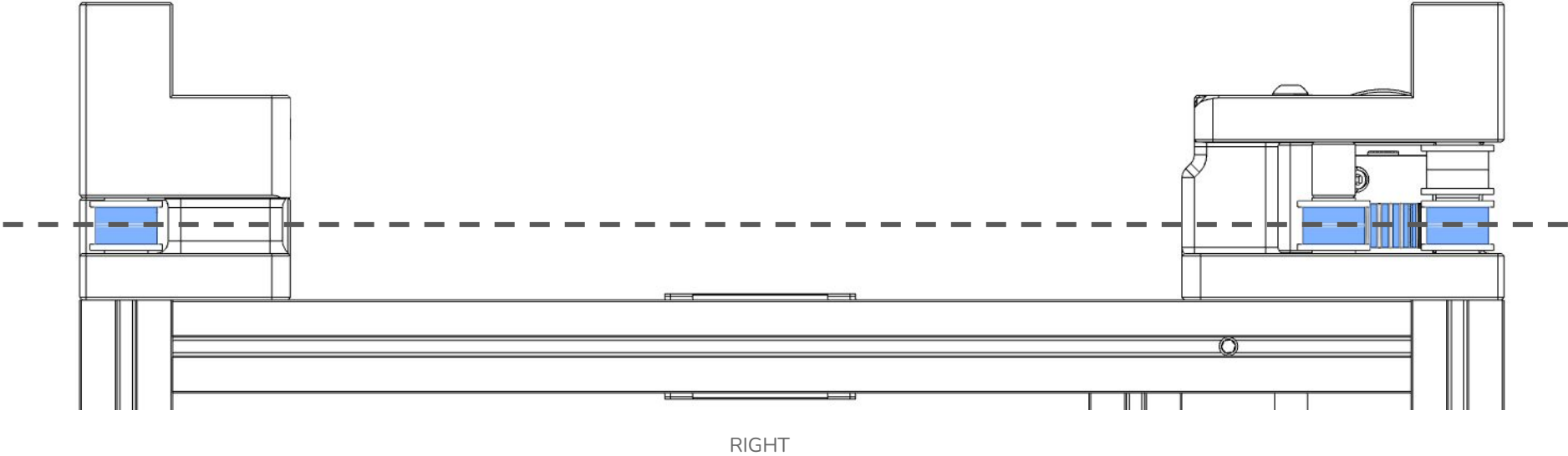

B IDLER

The B idler goes on the same side as the B drive unit. The bearing stacks should be the same heights. It also has a shorter top section.

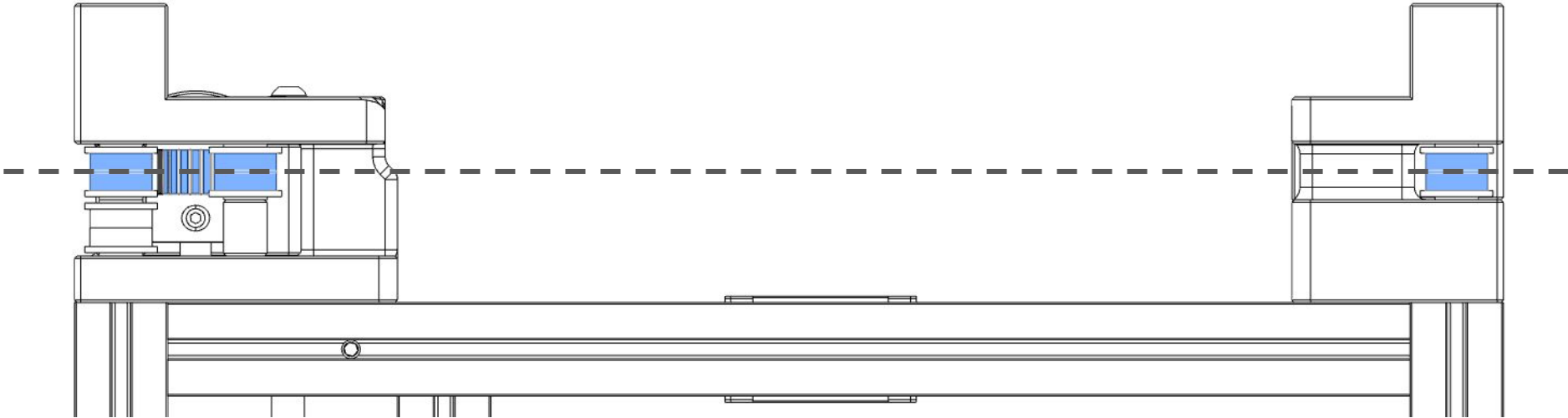

LEFT

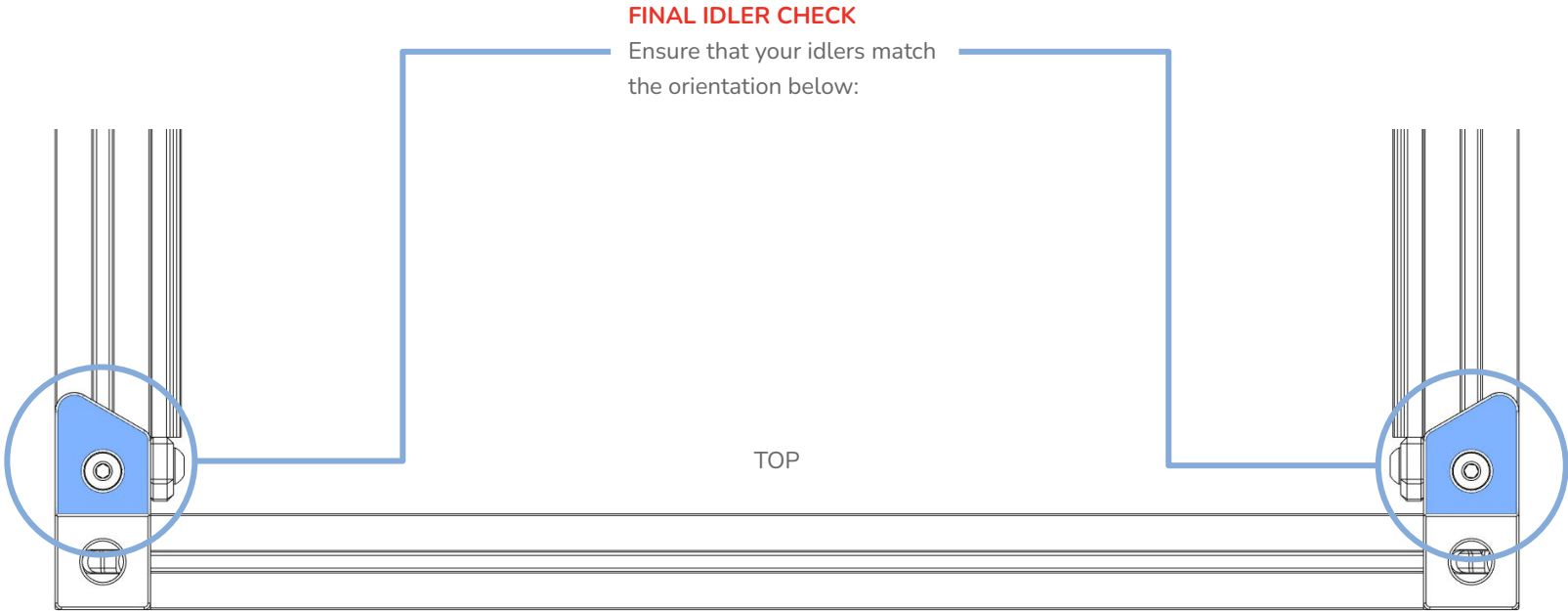



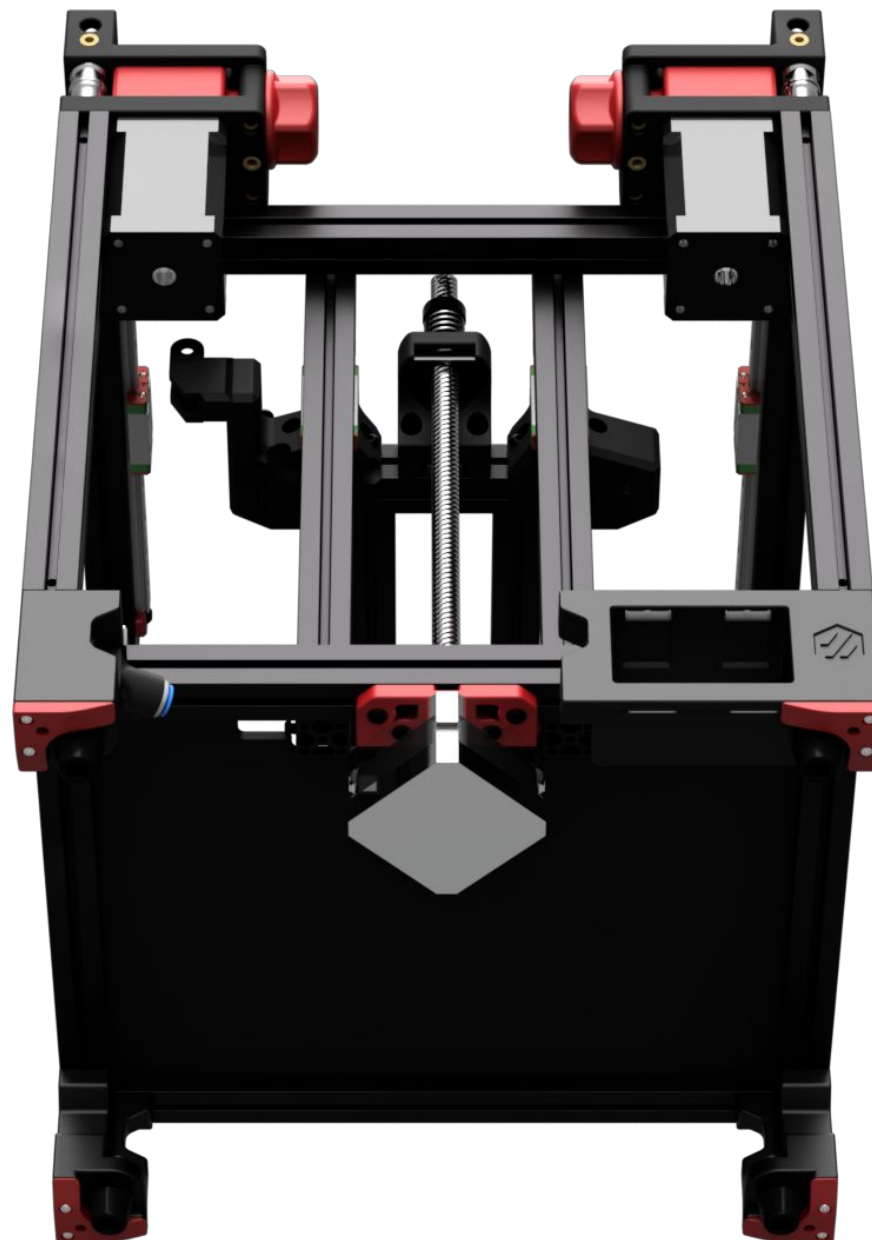

NUT HOLDER

Models for different sized leadscrew nuts are included in the released files.

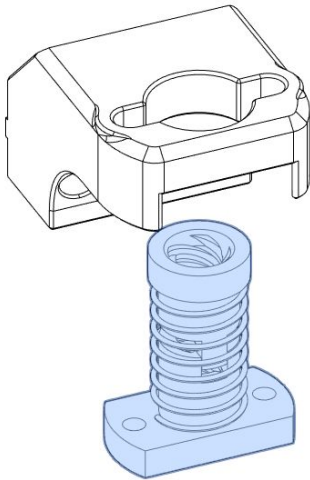

Anti-Backlash Nut

ROUND OR FLAT?

The anti-backlash nut **MUST** have a flat on at least 1 side, if you have a full round nut there is a printed tool in the STL folder that will help you measure and sand/cut the flat needed.

ANTI-BACKLASH

The anti-backlash nut works by applying constant pressure on the leadscrew threads. In order for it to function correctly it must be assembled such that the two pieces cannot spin independently. Refer to the linked video for assembly.



<https://voron.link/6zt4xt0>

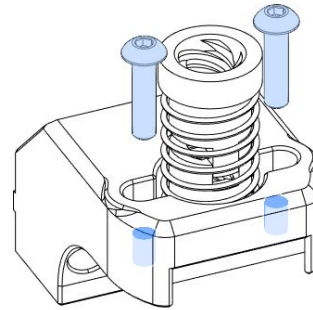

M3x12 BHCS

THROUGH-HOLE NUT?

If your leadscrew nut does not have M3 threads use longer screws and M3 lock nut to secure it.

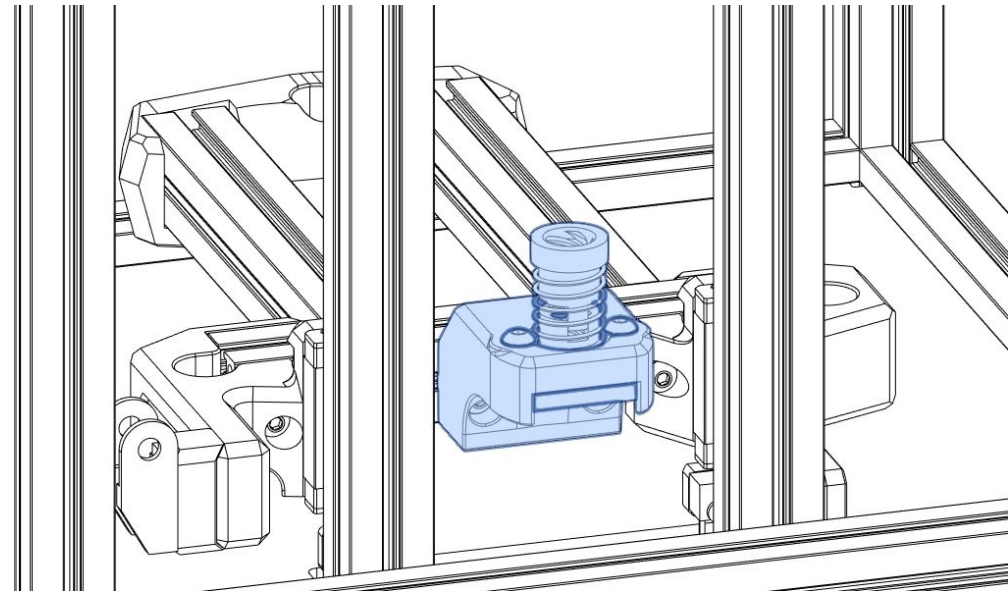

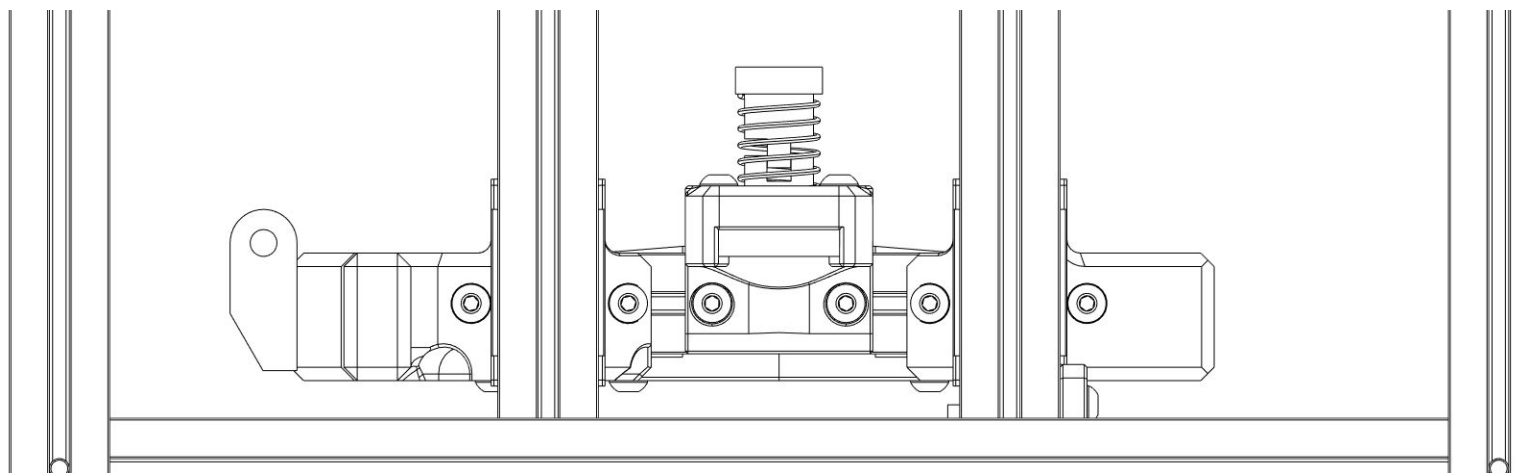
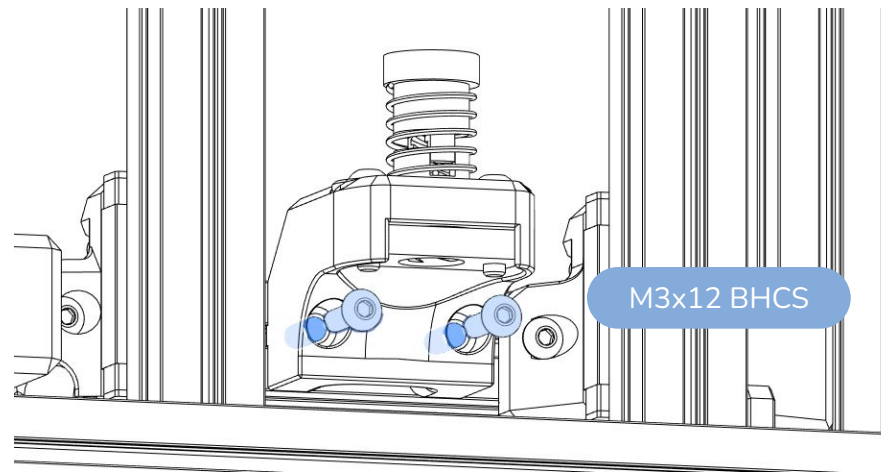

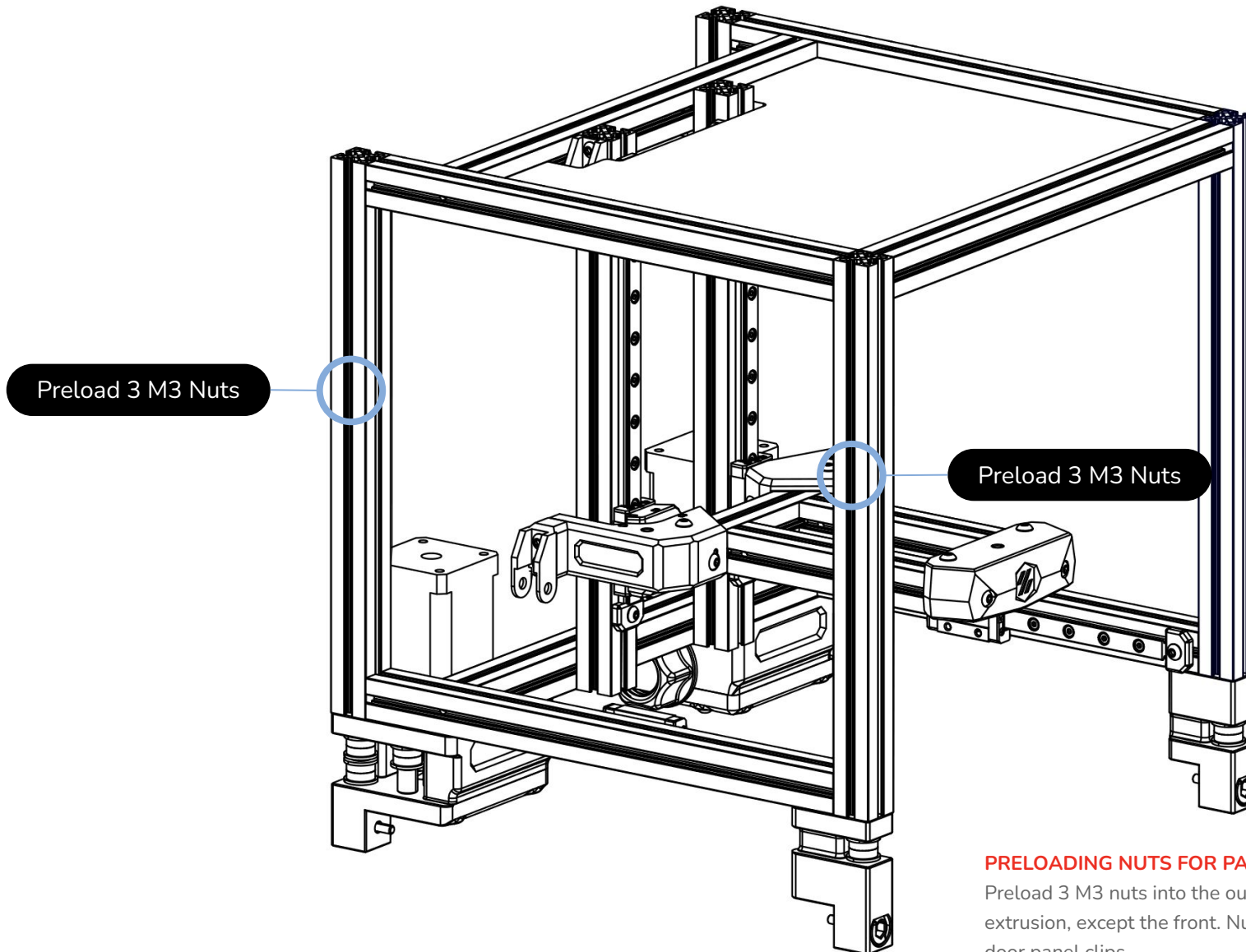

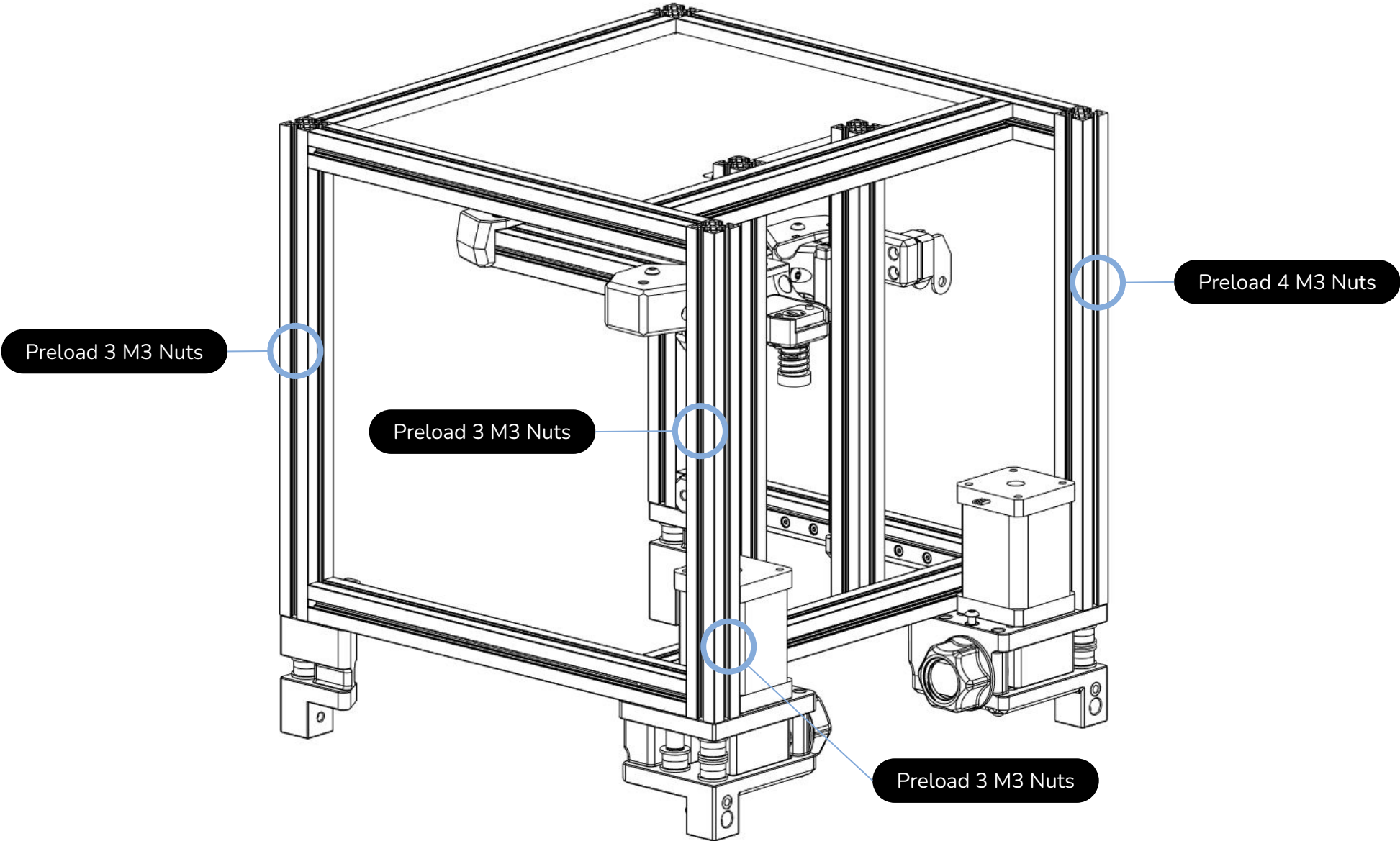



LAST CHANCE!

In the next few steps we will install the feet. In doing so we will be closing off the ends of the frame extrusions. This is the last chance to install preloaded M3 nuts into this portion of the frame, so pay special attention to the nut-checks on the next pages to make sure you have the correct number of M3 nuts in each extrusion slot.

Be a real shame if you forgot.

A real shame.



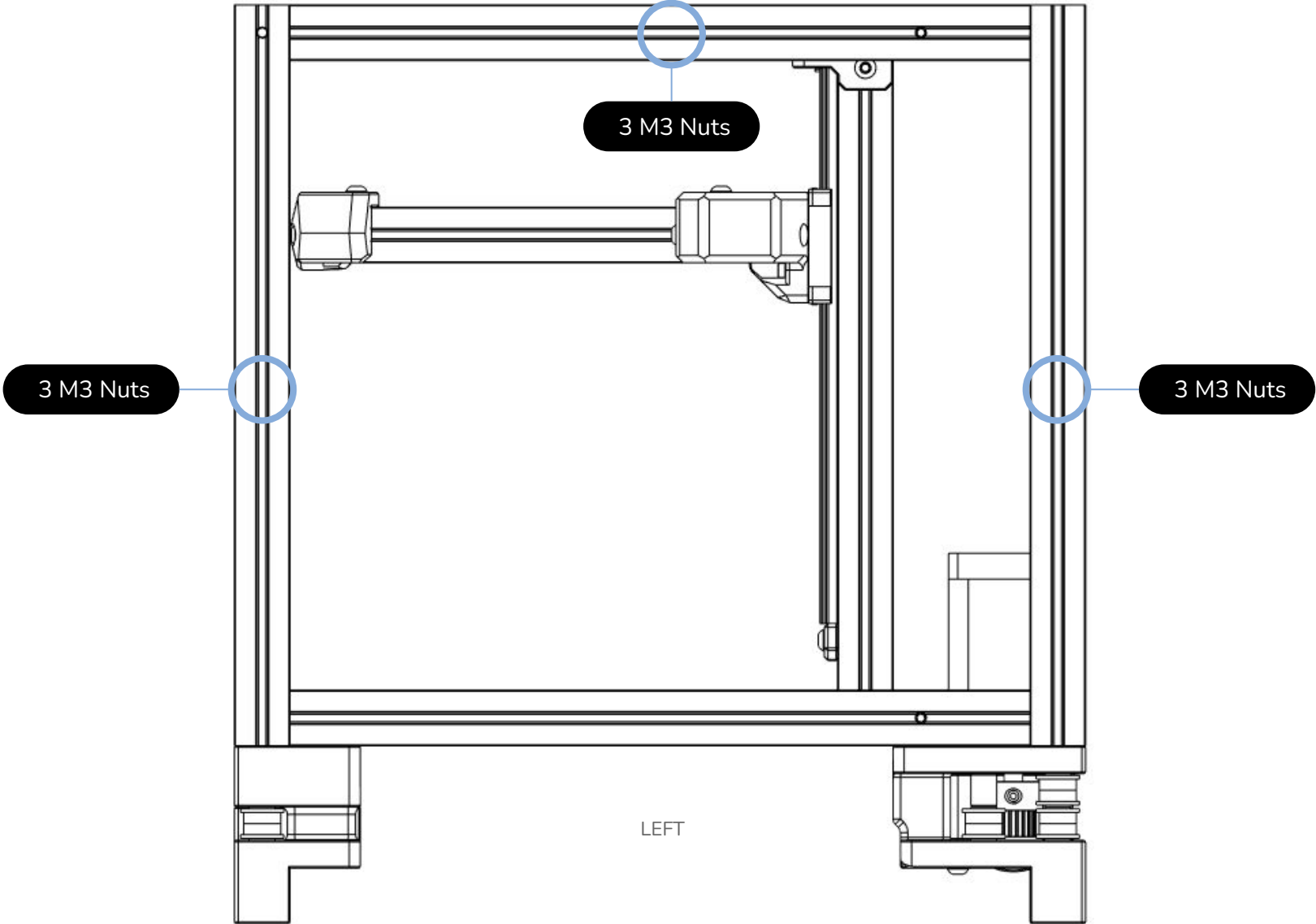

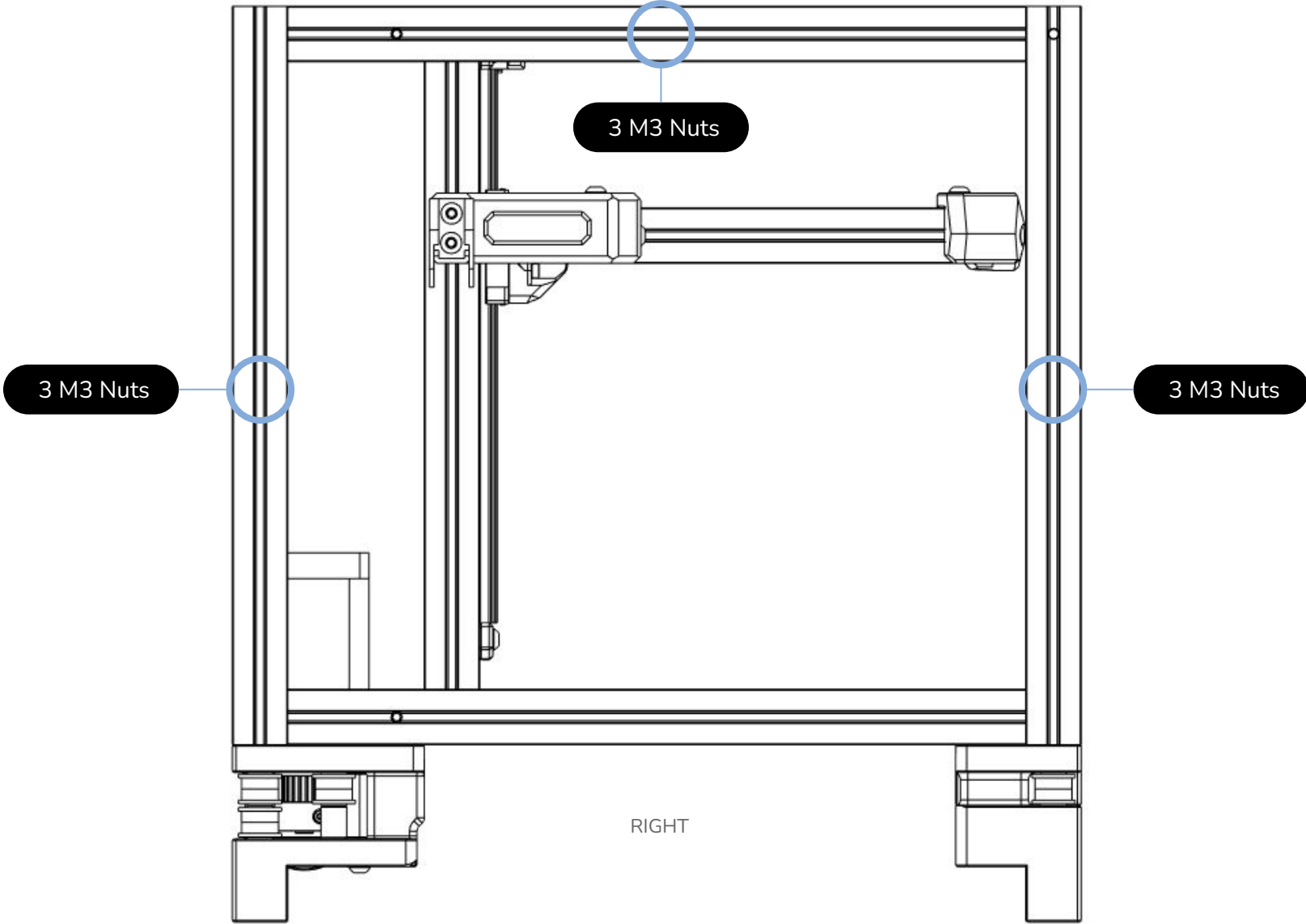

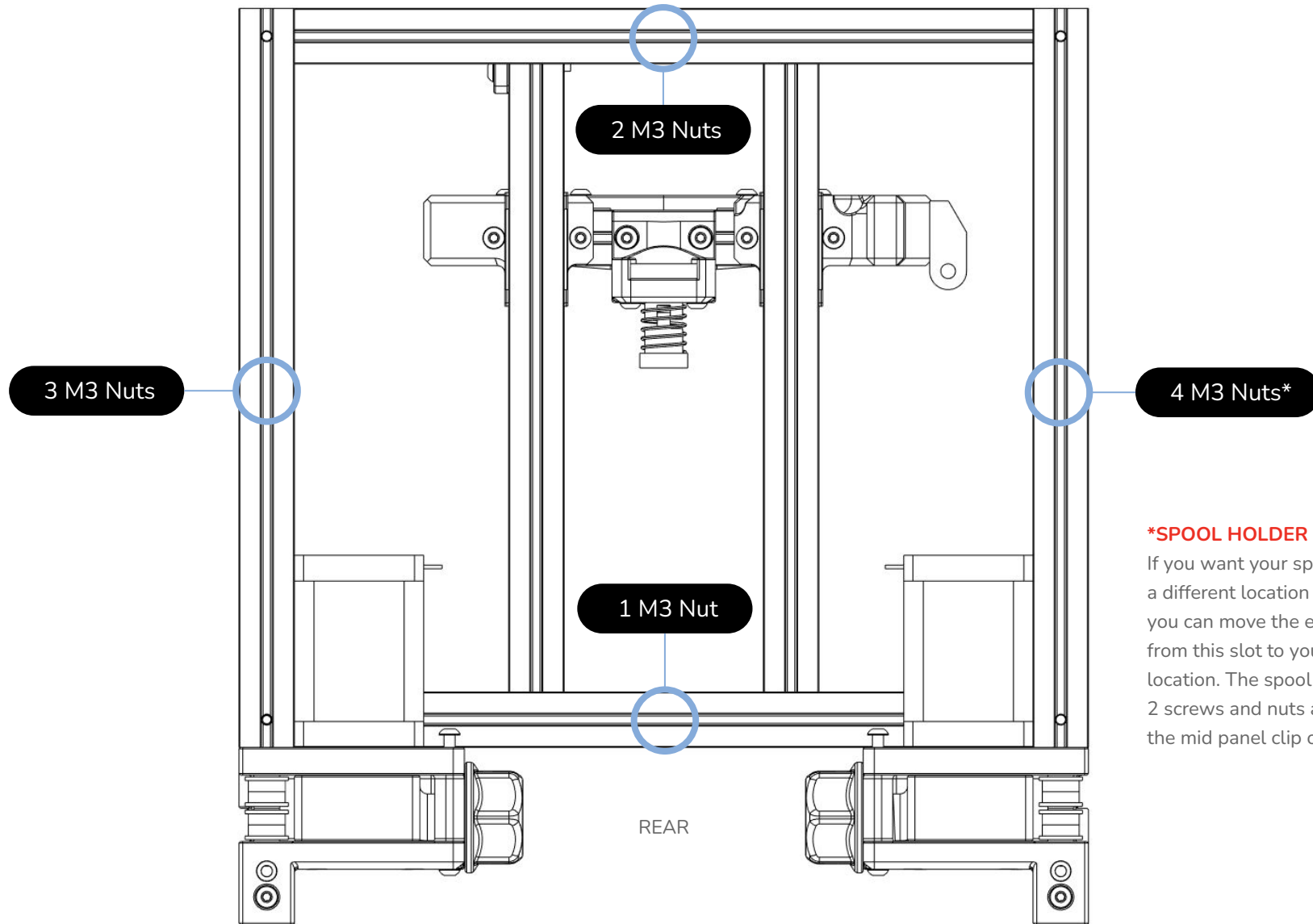

***SPOOL HOLDER**

If you want your spool holder in a different location than stock, you can move the extra hex nut from this slot to your desired location. The spool holder uses 2 screws and nuts and replaces the mid panel clip on this side.

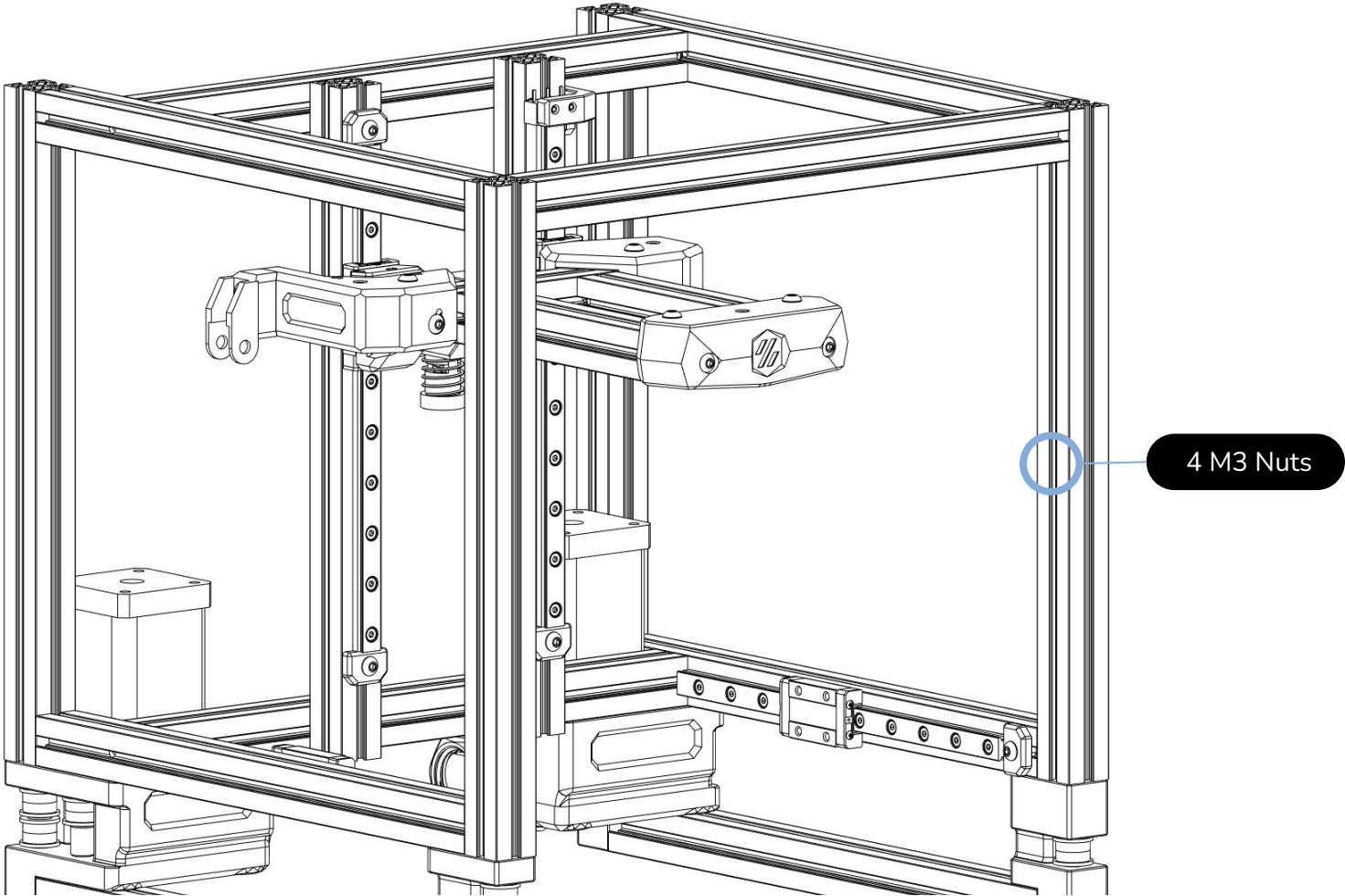

FRONT

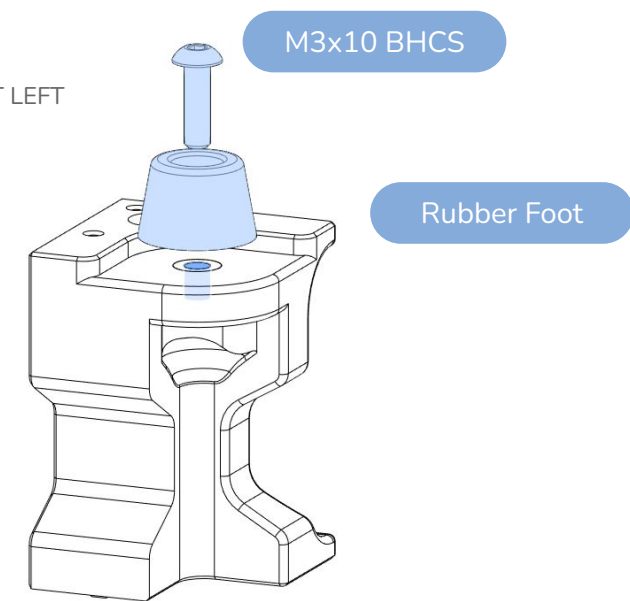
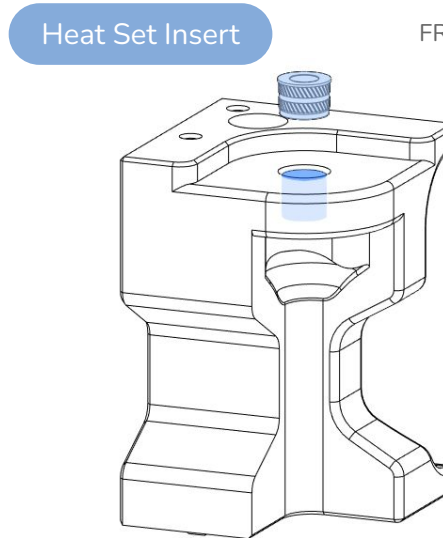
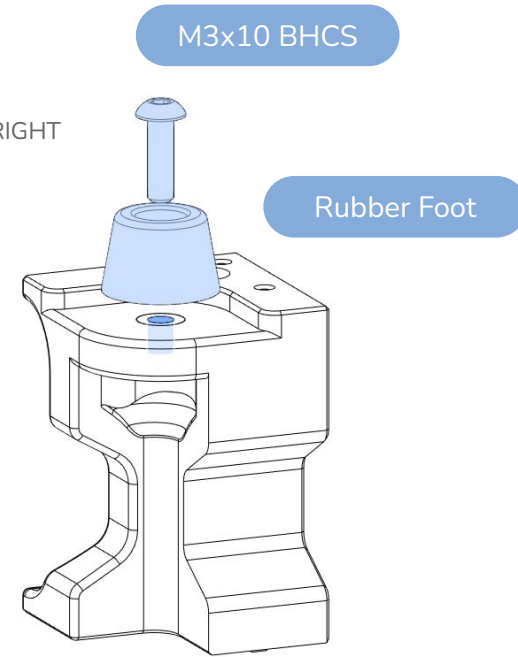
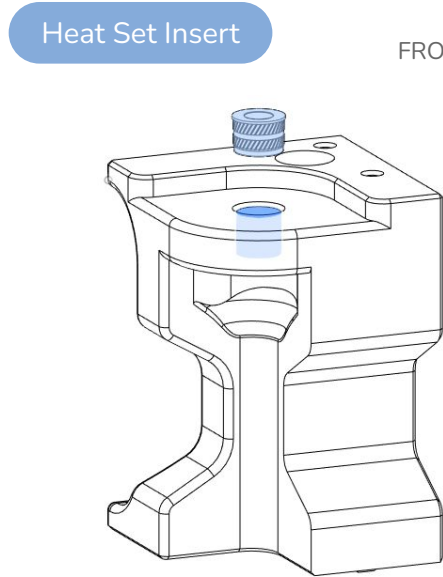
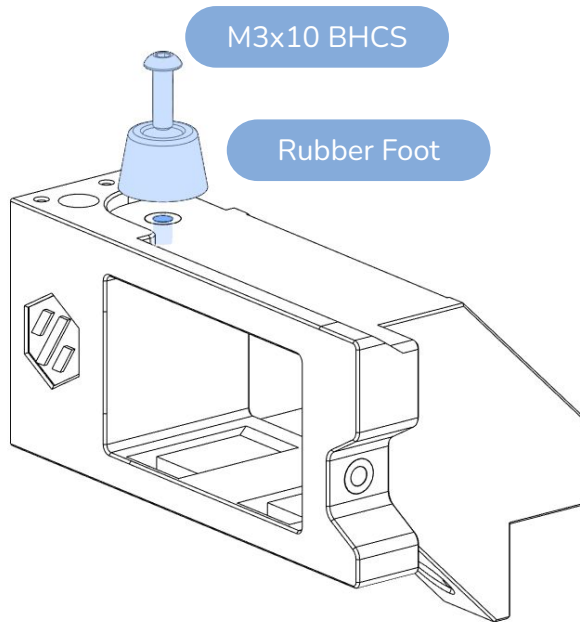
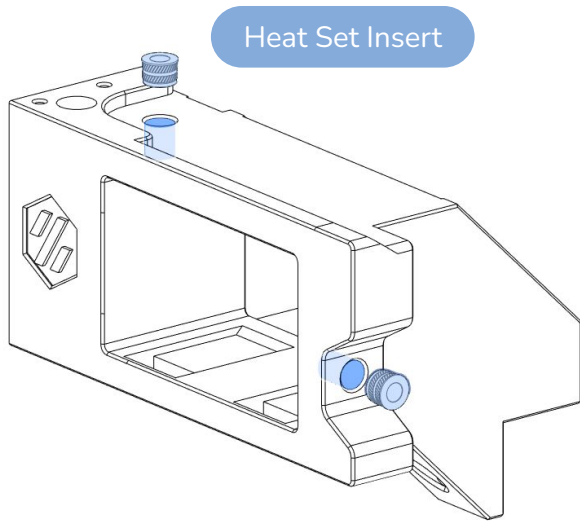

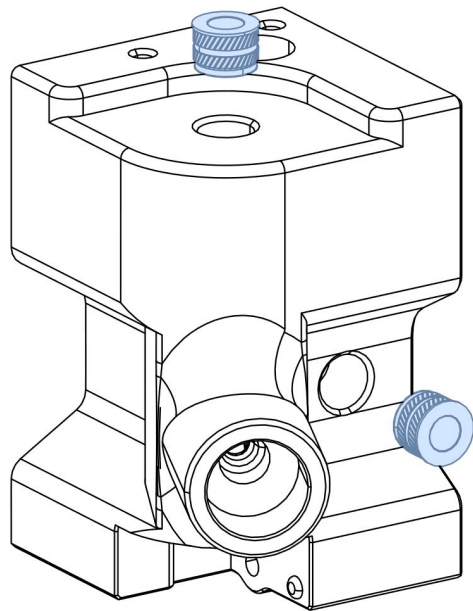

Heat Set Insert

REAR x1

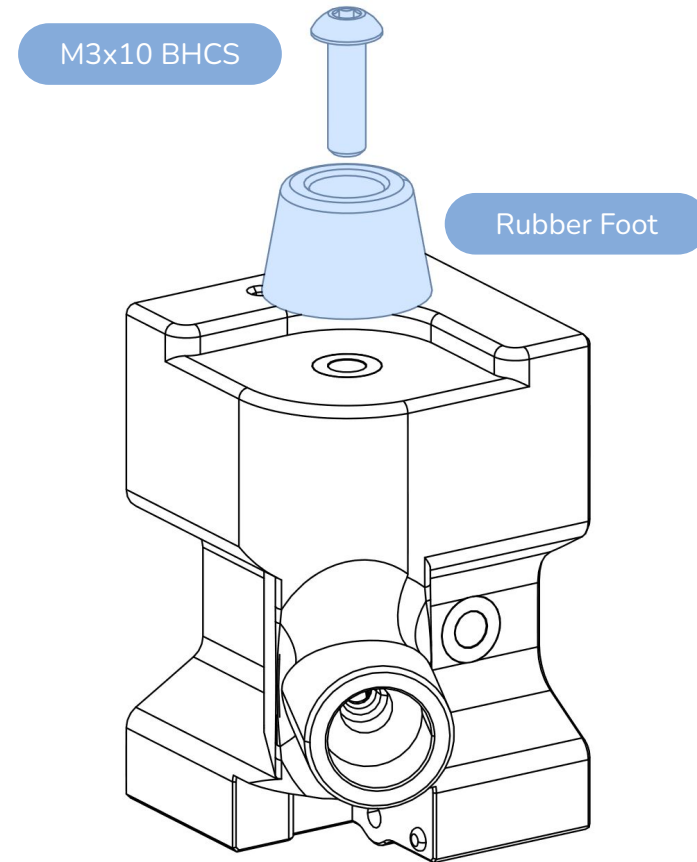

M3x10 BHCS

Rubber Foot

BOWDEN TUBE HOLE

The rear right foot has an extra hole that will hold the reverse bowden tube to guide filament from the spool into the printer.

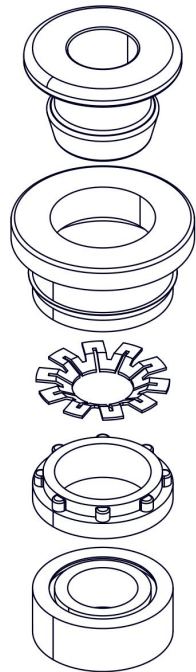

HOLY PIECES BATMAN!

The ECAS04 collets are made up of 5 individual pieces show on the left. We are going to discard the black rubber piece from the assembly. It is not needed for our application.

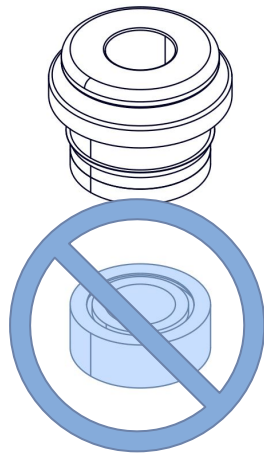

ECAS04 Bowden Fitting

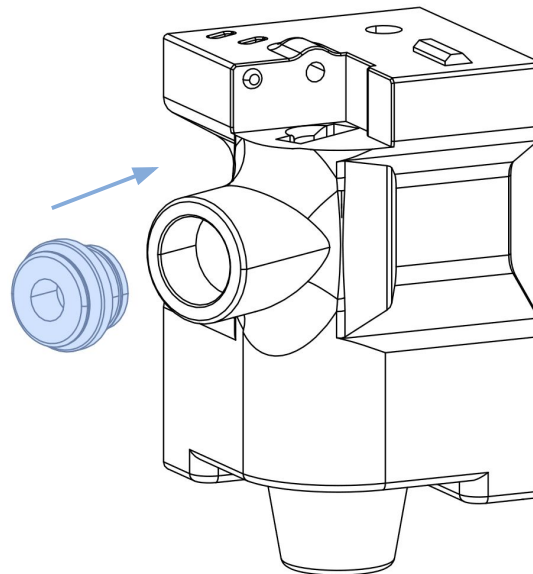

FALSE POSITIVES

The sensitivity of the runout sensor can be adjusted by applying tape to the OD of the bearing in order to increase the diameter and allow the switch to activate as precisely as you need.

MR85 Bearing

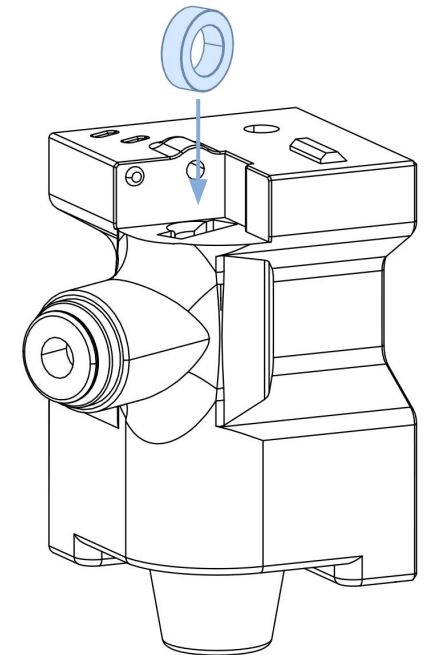

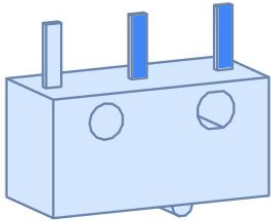
**PREPARE ONE ENDSTOP SWITCH**

Prepare the switch for the Filament runout sensor by soldering wire to the two highlighted terminals. This will setup the switch in a Normally Open state which is preferred for this type of use case.

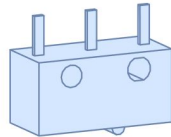

Filament Runout Sensor
Microswitch

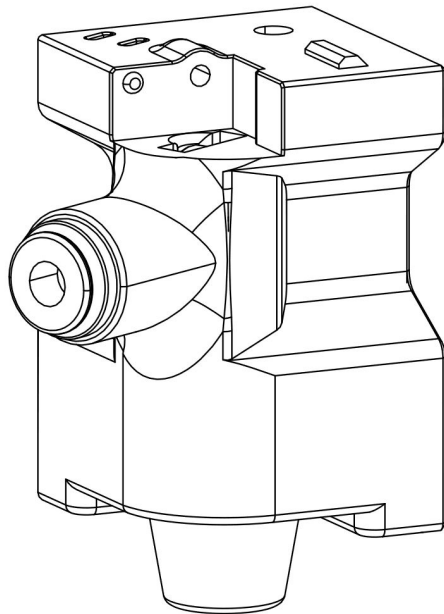

M2x10 Self Tapping Screw

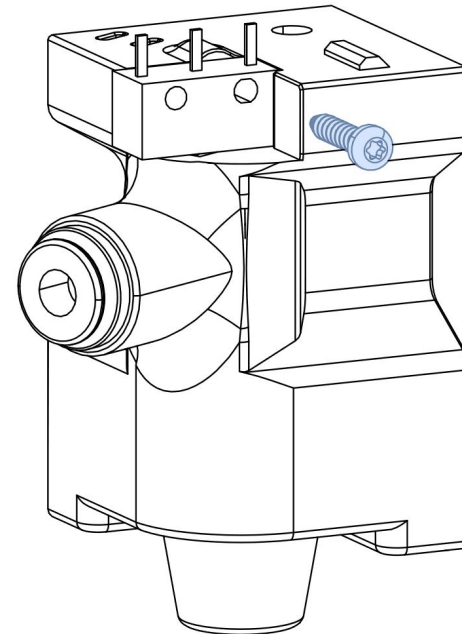

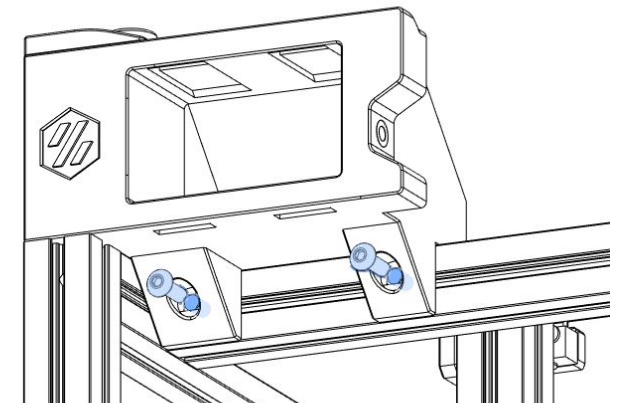
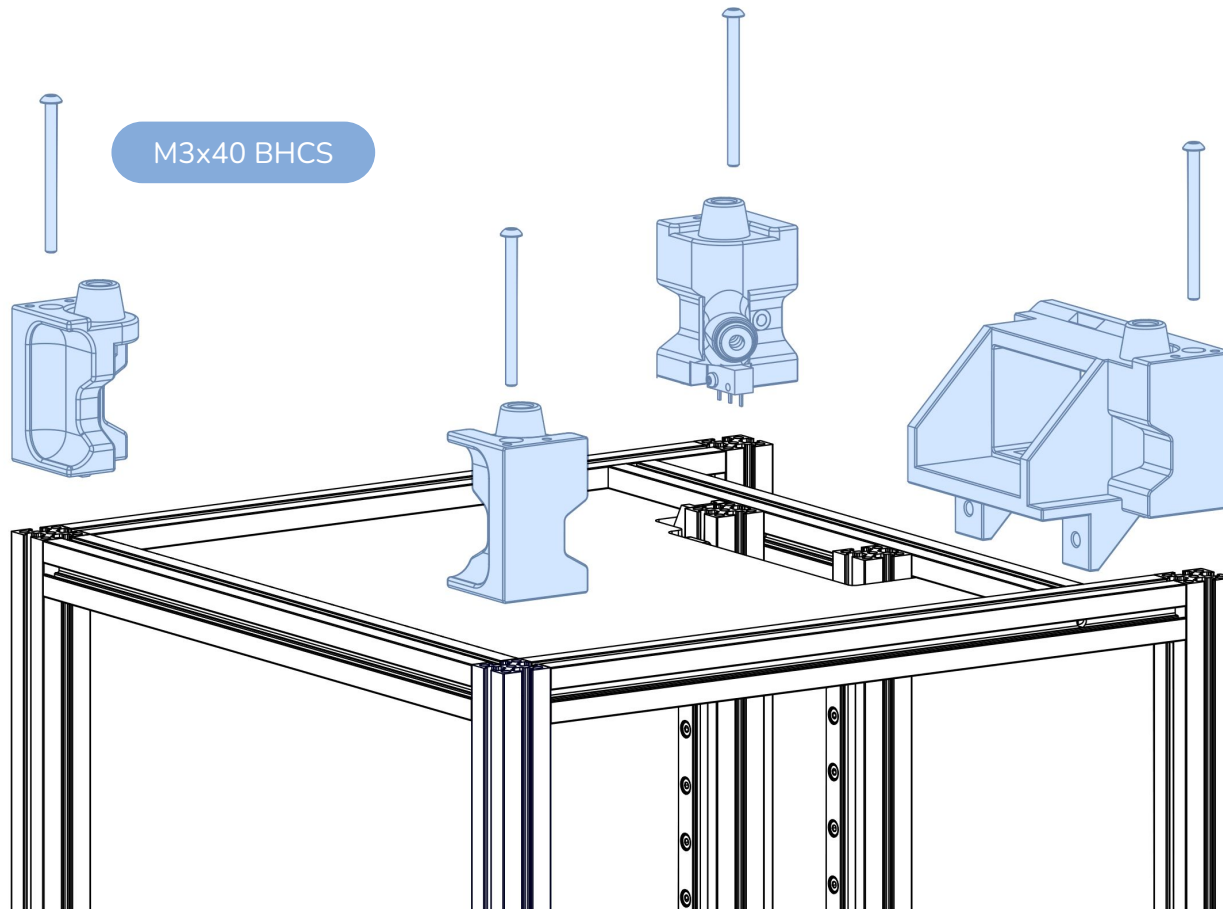

REMEMBER THESE HEX NUTS?

Secure inlet using the nuts we preloaded on page 52.

M2x10 Self Tapping

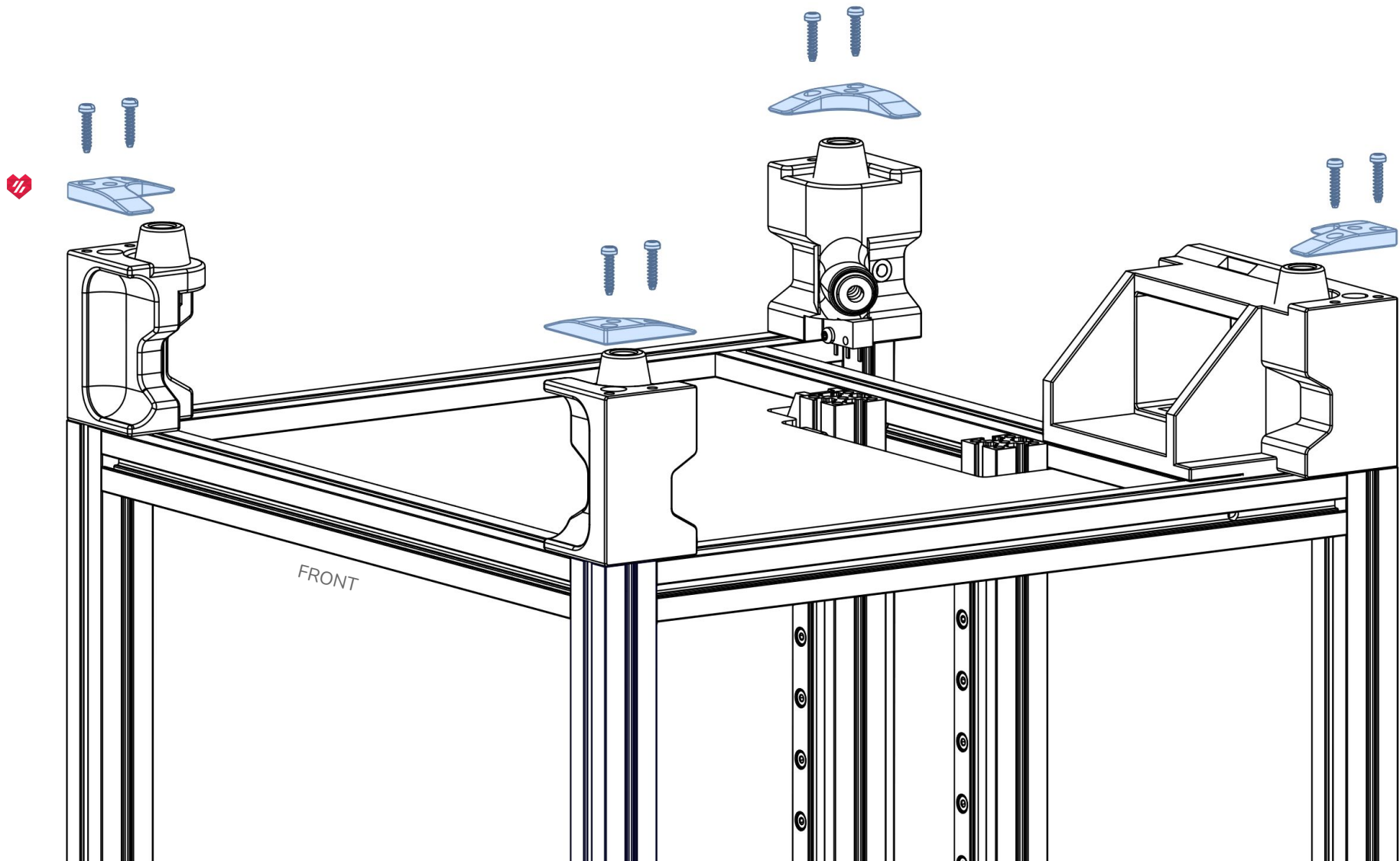

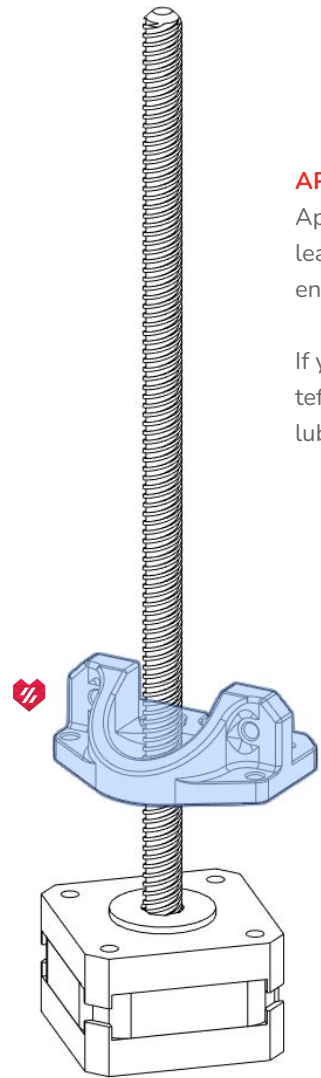

NEMA17 Pancake Motor

APPLY LUBRICATION

Apply a **thin layer** of grease to the leadscrew to prevent rust and ensure a smooth operation.

If you are using a POM nut with a teflon coated leadscrew, additional lubrication is not needed.

M3x8 BHCS

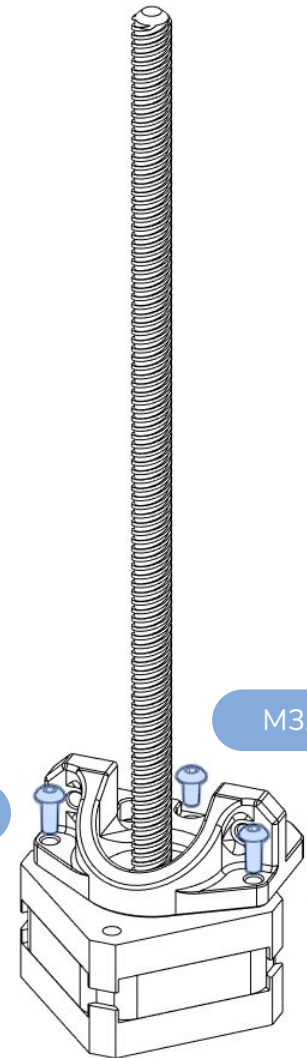

M3x6 BHCS

M3x8 BHCS

WIRING

The direction of the motor wires does not matter, use whatever makes the most sense for your electronics layout.

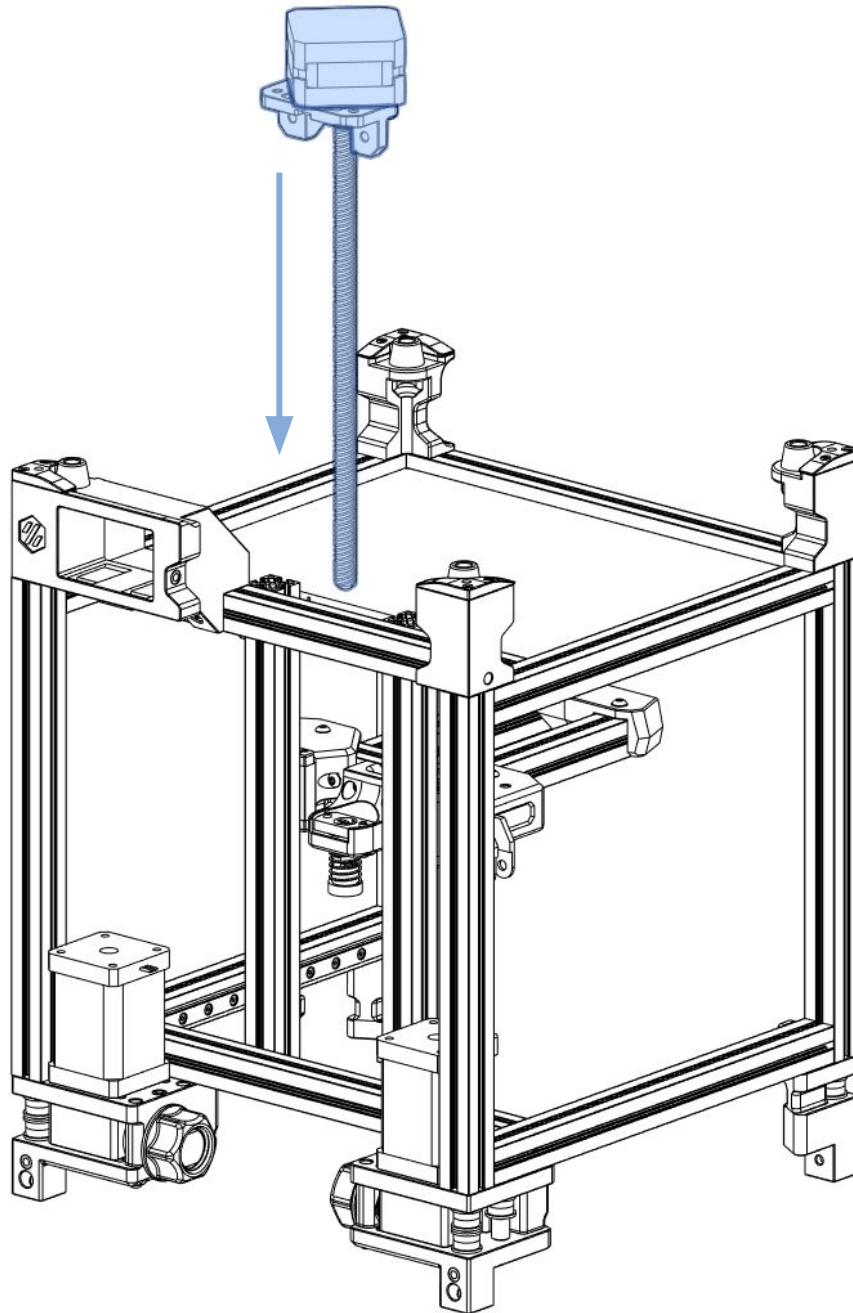

<https://voron.link/6zt4xt0>

ANTI-BACKLASH

The anti-backlash nut works by applying constant pressure on the leadscrew threads. In order for it to function correctly it must be assembled such that the two pieces cannot spin independently. Refer to the linked video above for assembly.

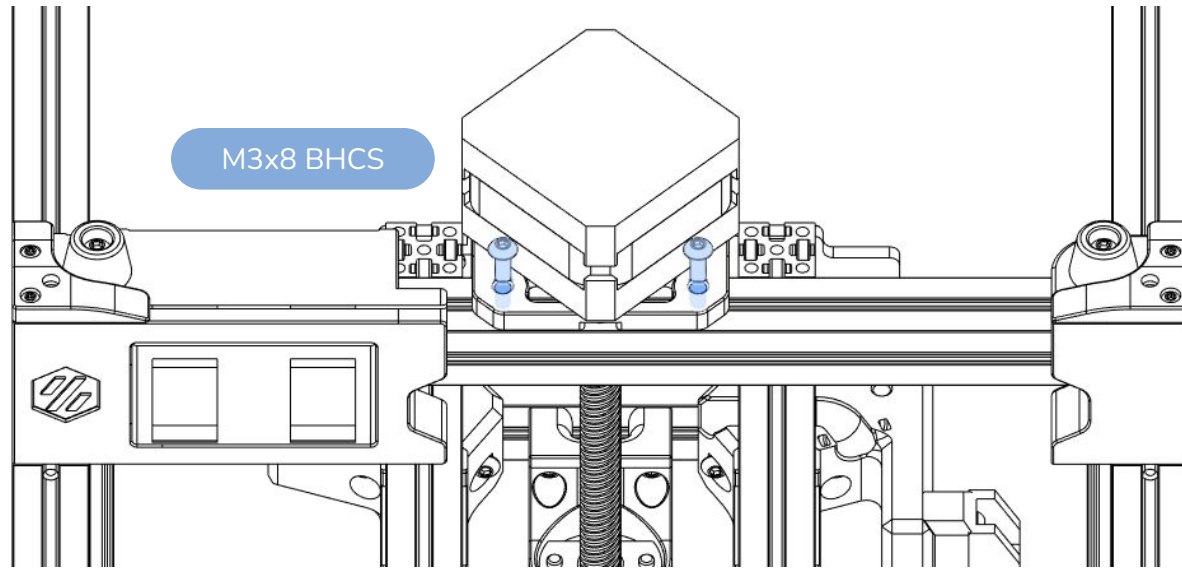

KEEP THEM LOOSE

Proceed to the next step before fully tightening these screws.

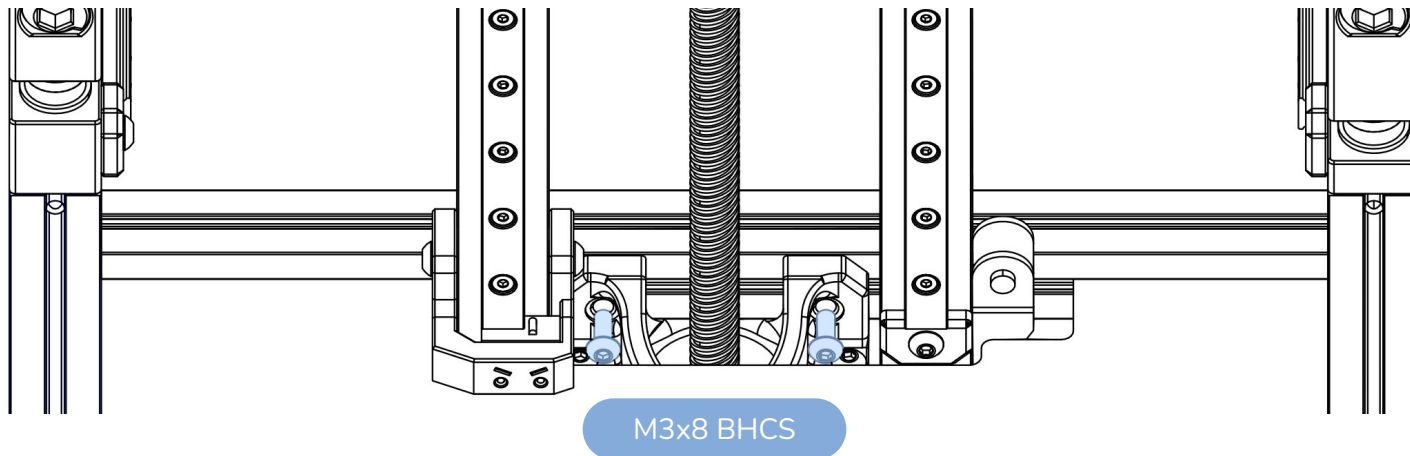

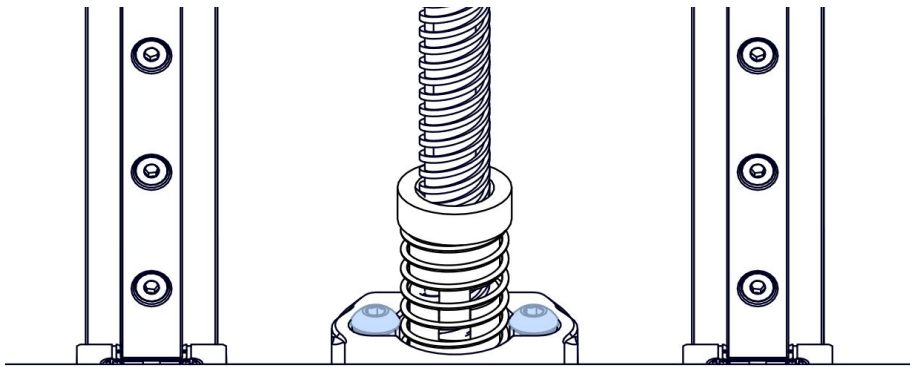
**TAKE YOUR TIME HERE**

Loosen these two screws, we are going to ensure that our bed movement is smooth, if you get a grinding noise or skipping of the Z motor when cycling the bed later, this is the step you will have to return to.

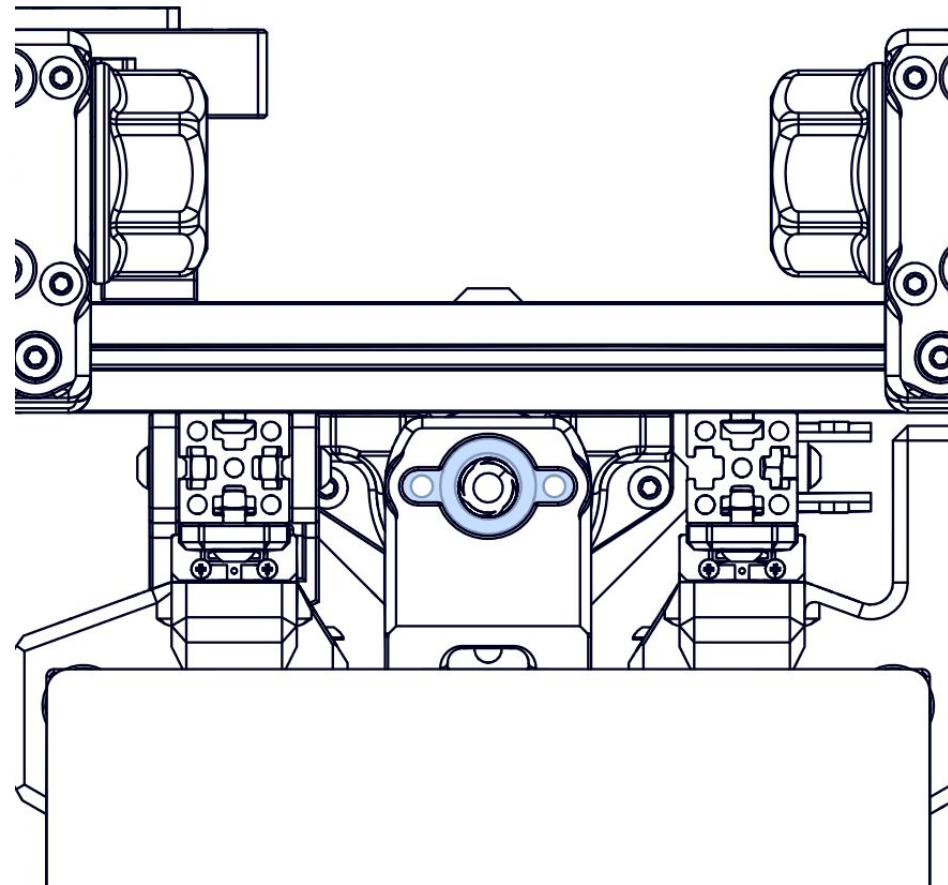
**ALIGNMENT OF THE BACKLASH NUT**

Move your bed assembly all the way to the lowest position. We want to make sure that our motor and leadscrew assembly is in line with our T8-nut block and the backlash nut assembly. There is excess room available around the screw holes of the backlash nut to ensure that you can attach the nut and not cause binding in the z axis at its lowest position even if it is slightly off center.

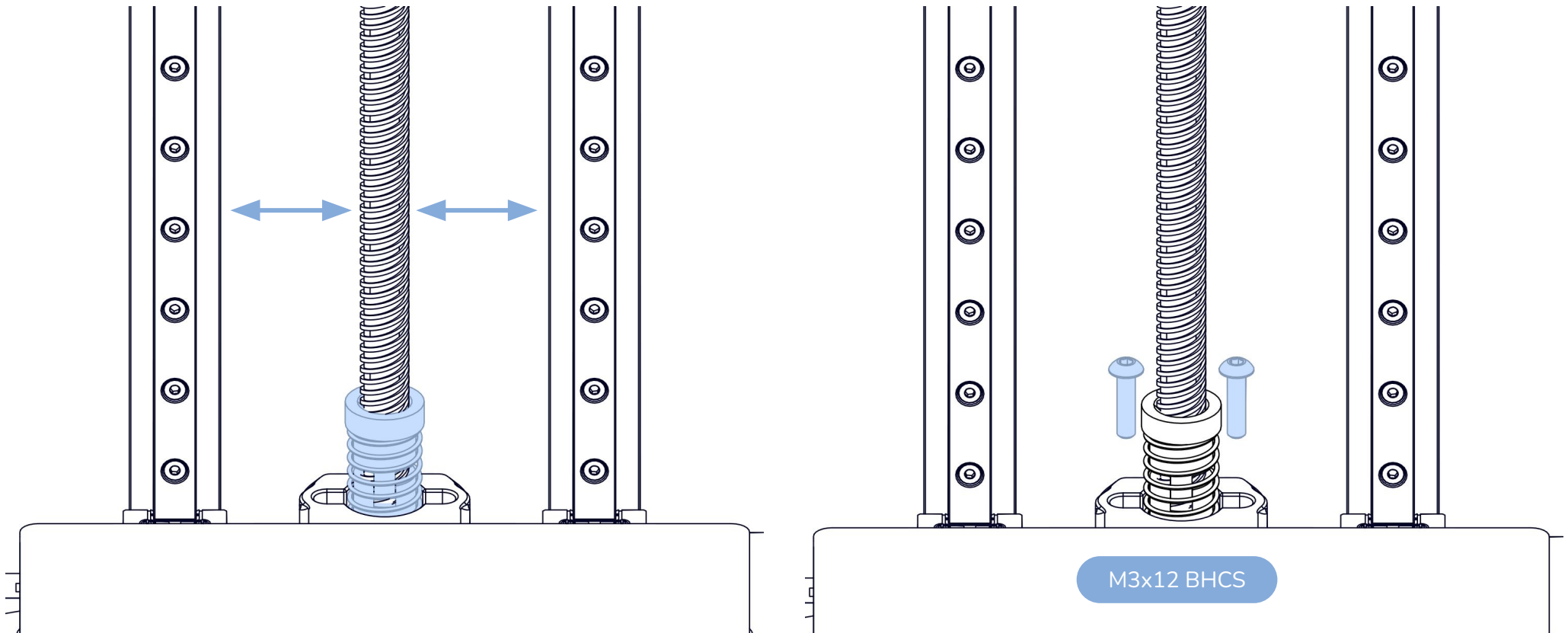
**ALIGNMENT OF THE LEADSCREW**

Make sure you motor is positioned approximately in the center of the Z rails then you can tighten the 4 M3x8 BHCS that secure the motor mount to the frame.

LOCK IT DOWN

Re-tighten or Re-insert the M3x12 screws that we loosened on the previous page.

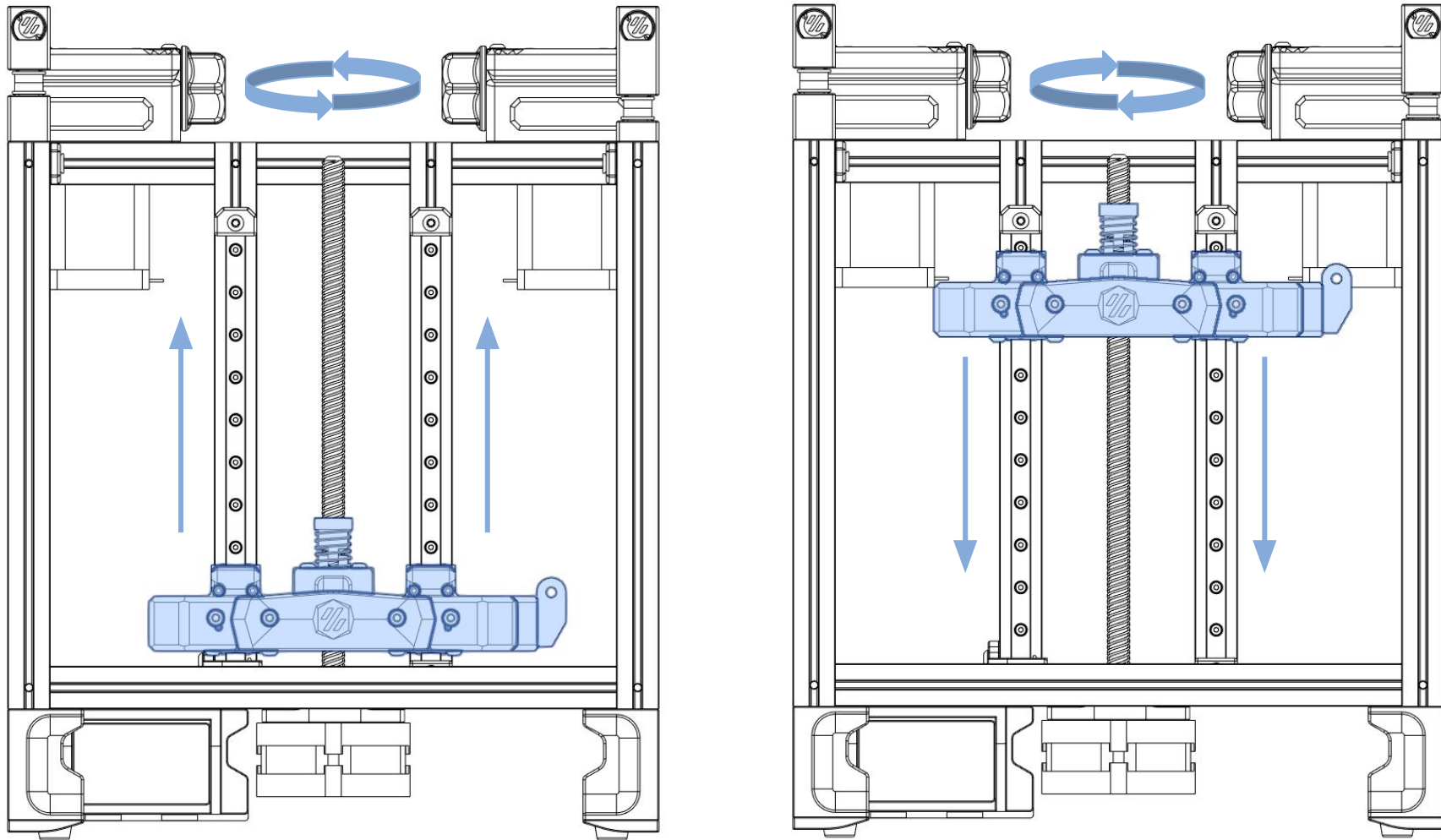

CHECK ALIGNMENT

Manually cycle the bed up and down to ensure proper alignment.





ROYAL FLUSH

These inserts will sit slightly below the surface.

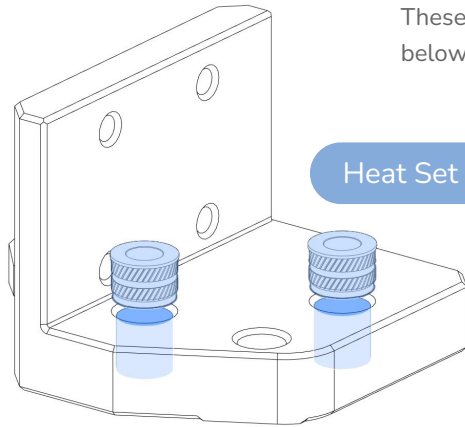

Heat Set Insert

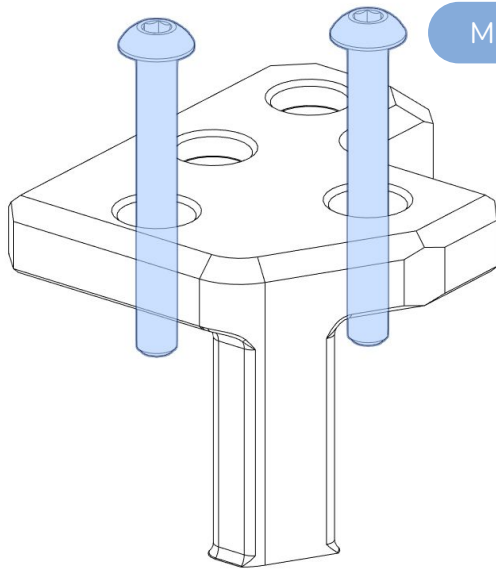

M3x25 BHCS

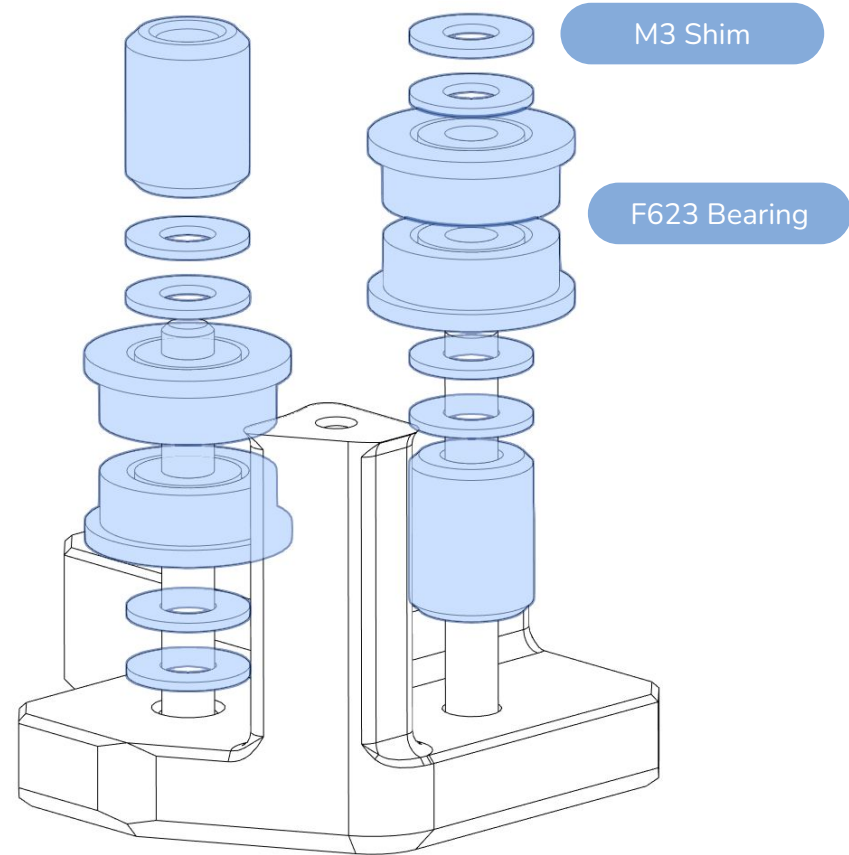

M3 Shim

F623 Bearing

UPSIDE DOWN ASSEMBLY

For ease of assembly we recommend to assemble the XY joints upside-down.

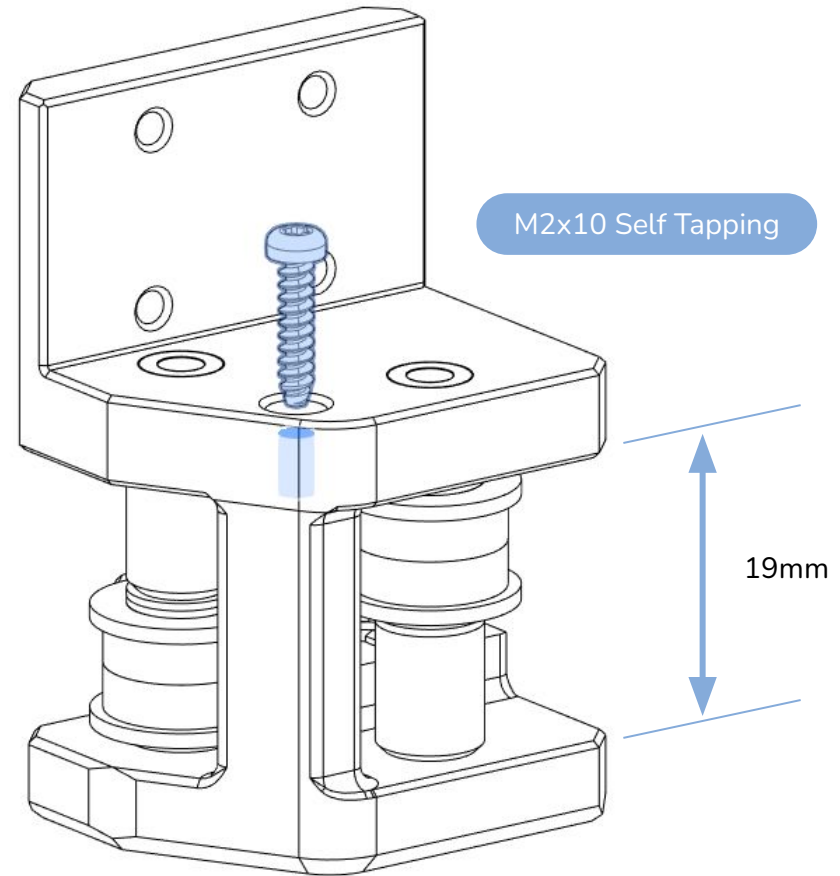
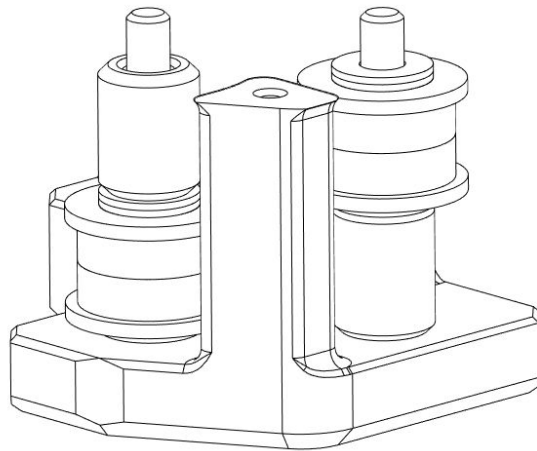
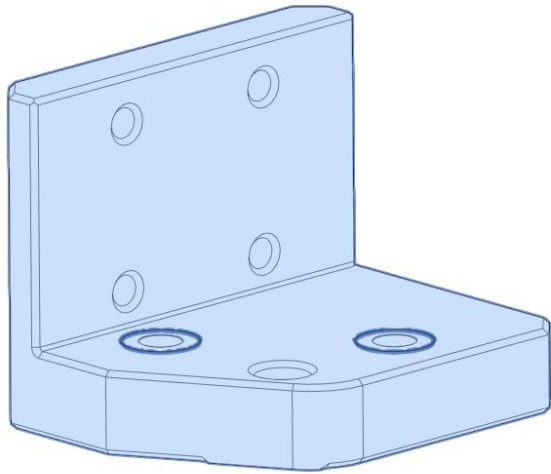

M2x10 Self Tapping

19mm

MIRROR MIRROR ON THE WALL

The left and right X/Y joint pieces are easy to mix up. Be sure the parts you are using match the images above

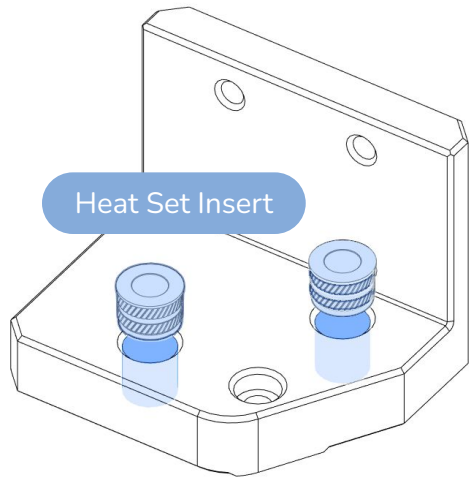

ROYAL FLUSH
These inserts will sit slightly below the surface.

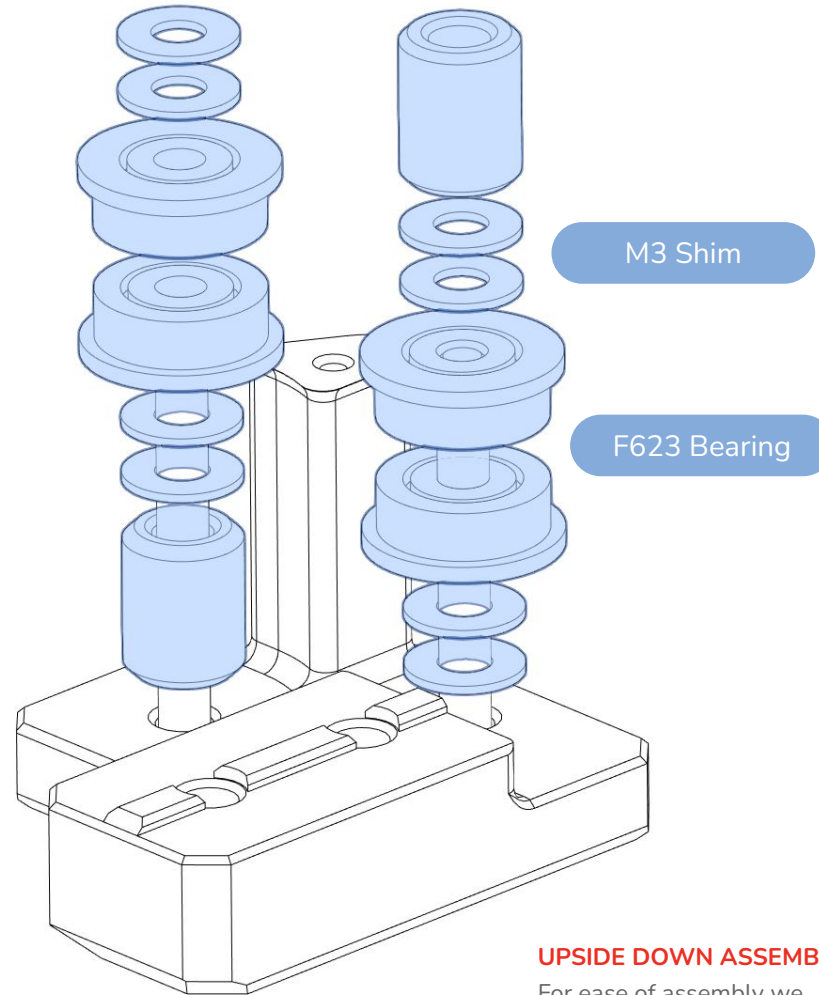
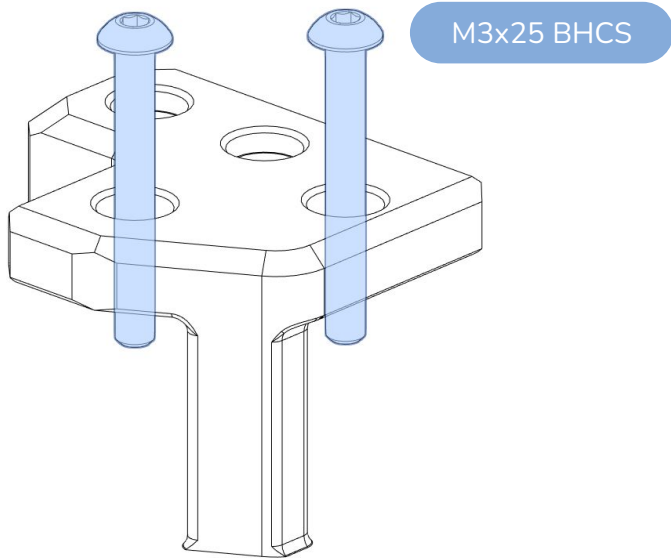

UPSIDE DOWN ASSEMBLY
For ease of assembly we recommend to assemble the XY joints upside down.

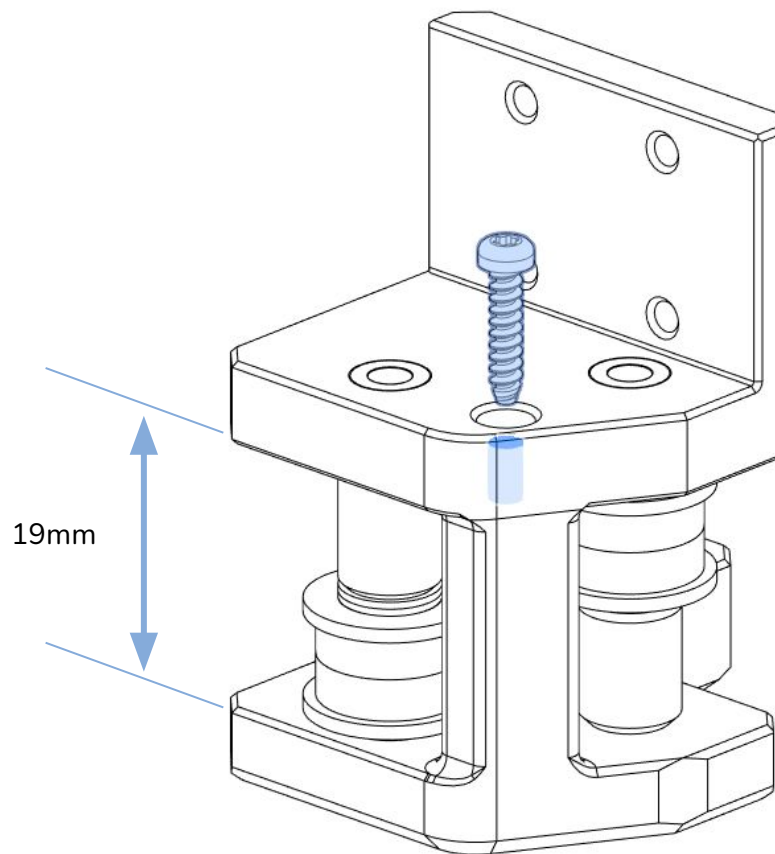
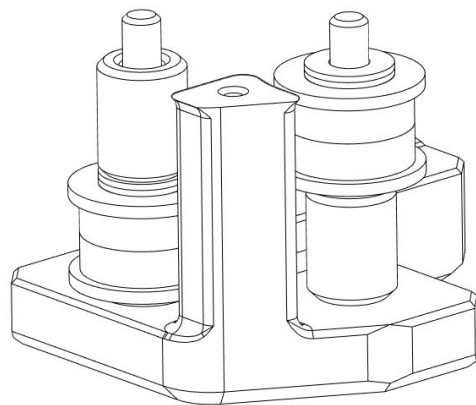
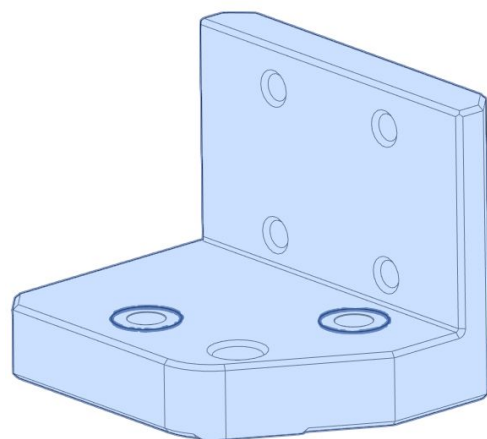

M2x10 Self Tapping

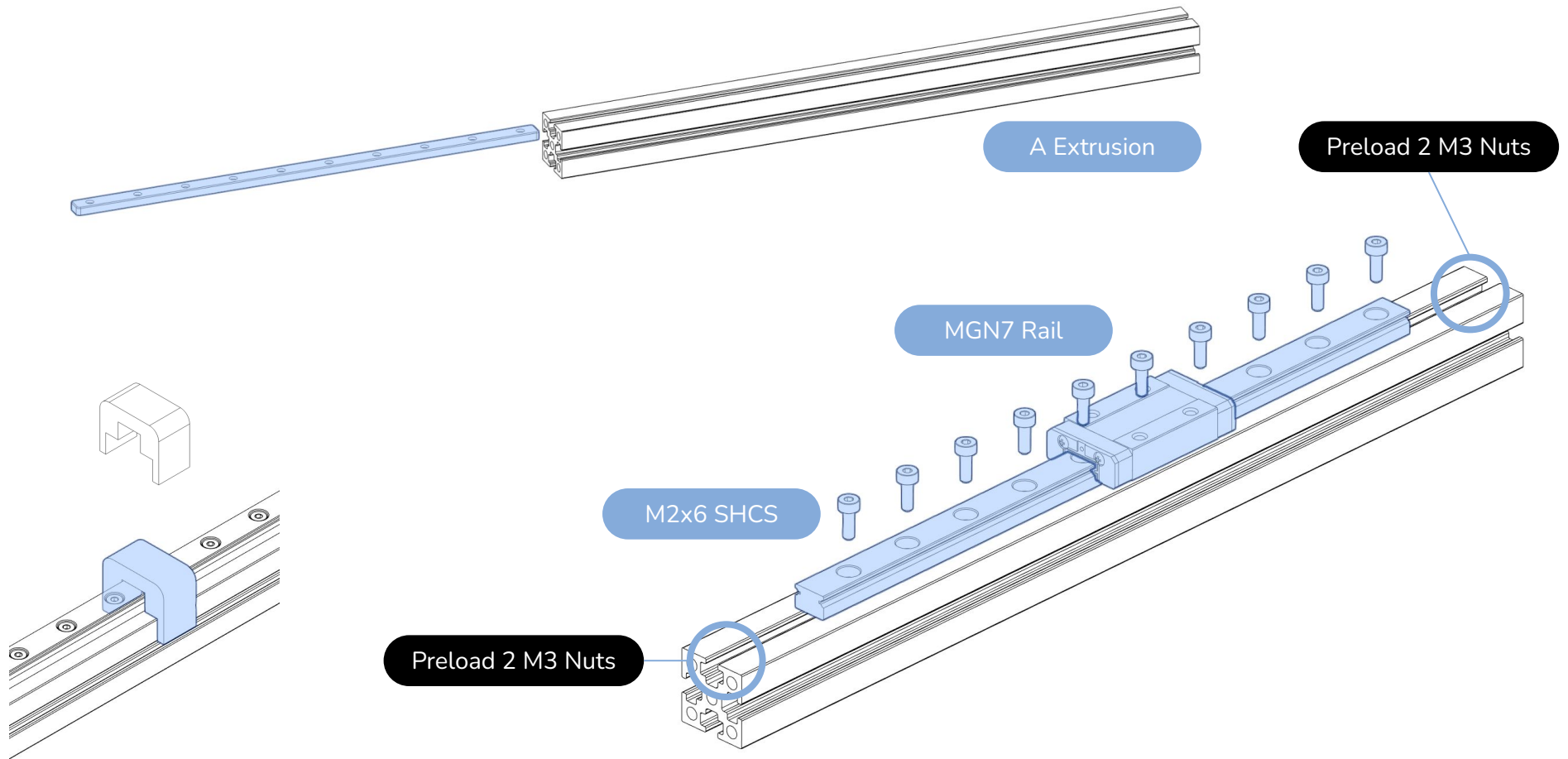

RAIL INSTALLATION GUIDE

Use the guides to position the rail in the center of the extrusion prior to fastening the screws.

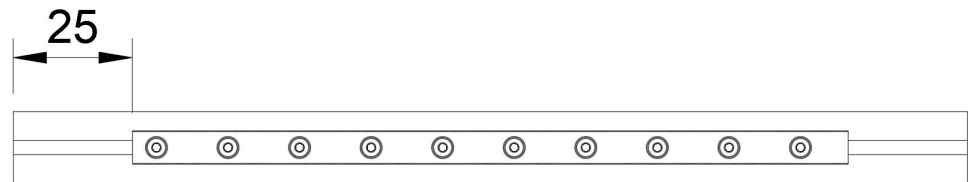

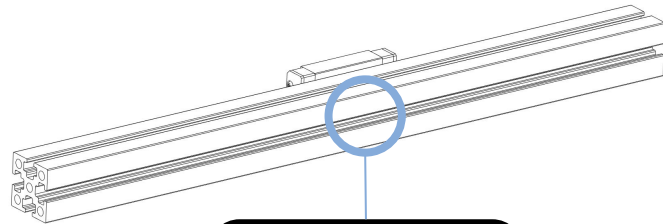

Preload 2 M3 Nuts

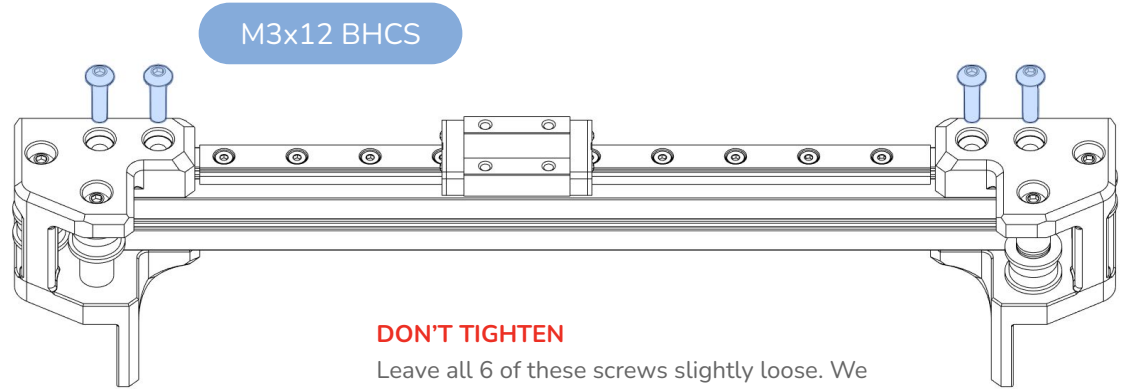

M3x12 BHCS

DON'T TIGHTEN
Leave all 6 of these screws slightly loose. We need to attach the XY joints to the Y carriages before locking them down to the gantry.

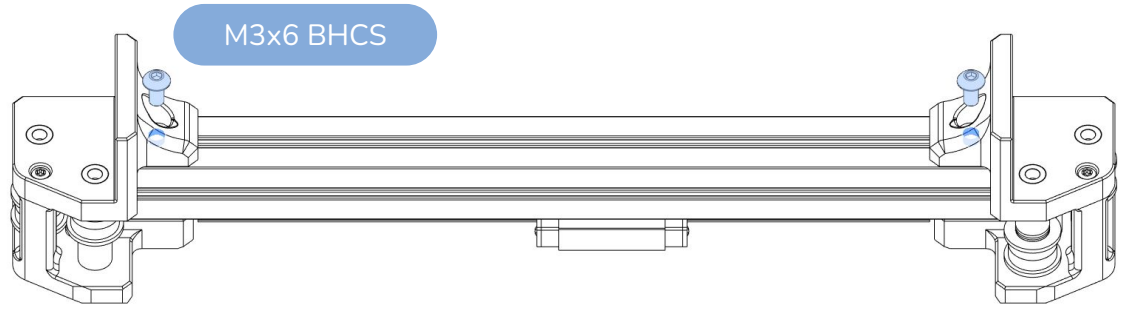
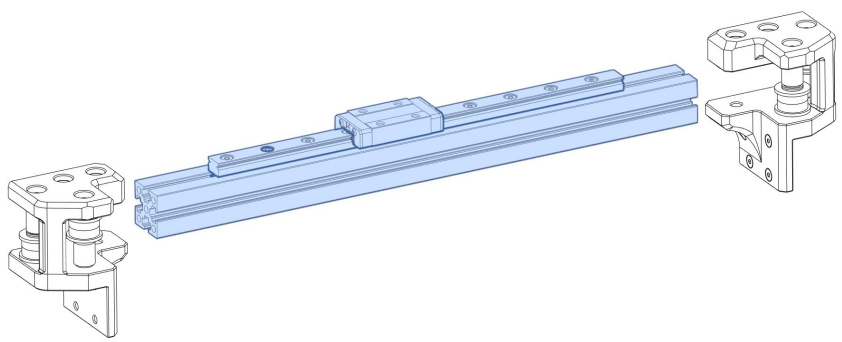

M3x6 BHCS

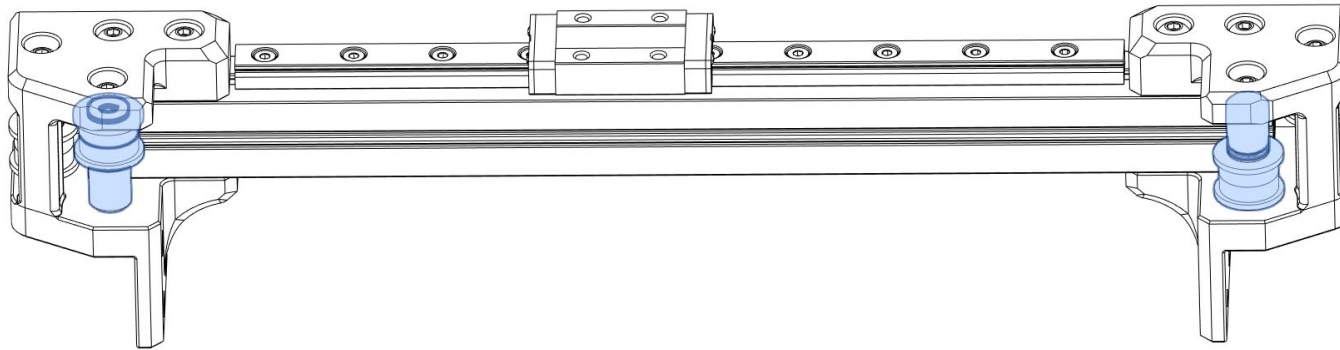
**CHECK YOUR WORK**

Compare your assembled parts to the graphic shown here. Pay attention to the pulley orientation and alignment with the bearing stack ups.

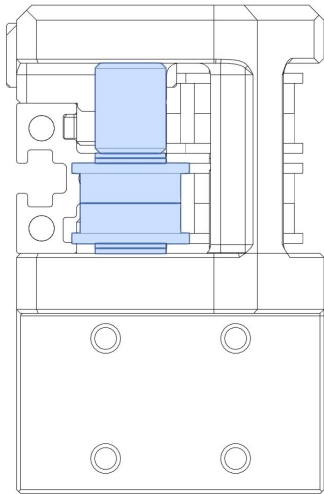
**SIDE VIEW**

This image shows the rear idler on the left side.

ENDSTOPS?...WHERE WE'RE GOING WE DON'T NEED ENDSTOPS

The v0.2 uses sensorless homing on the X and Y axis in place of mechanical endstops. For a guide on setting up sensorless homing, visit <https://voron.link/2ictw9i>.

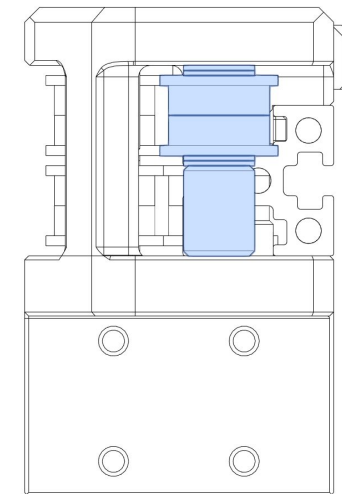
**SIDE VIEW**

This image shows the rear idler on the right side.

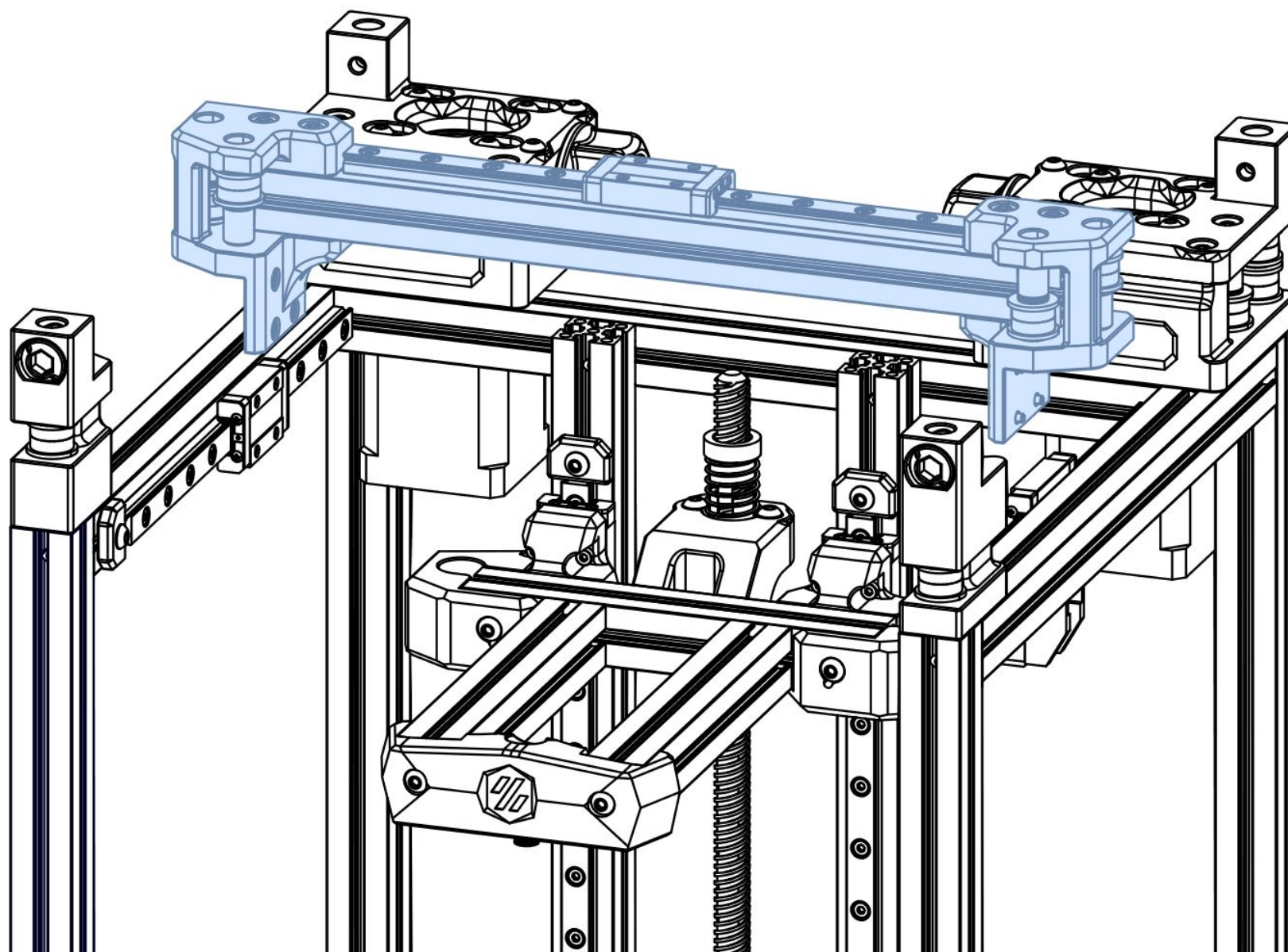

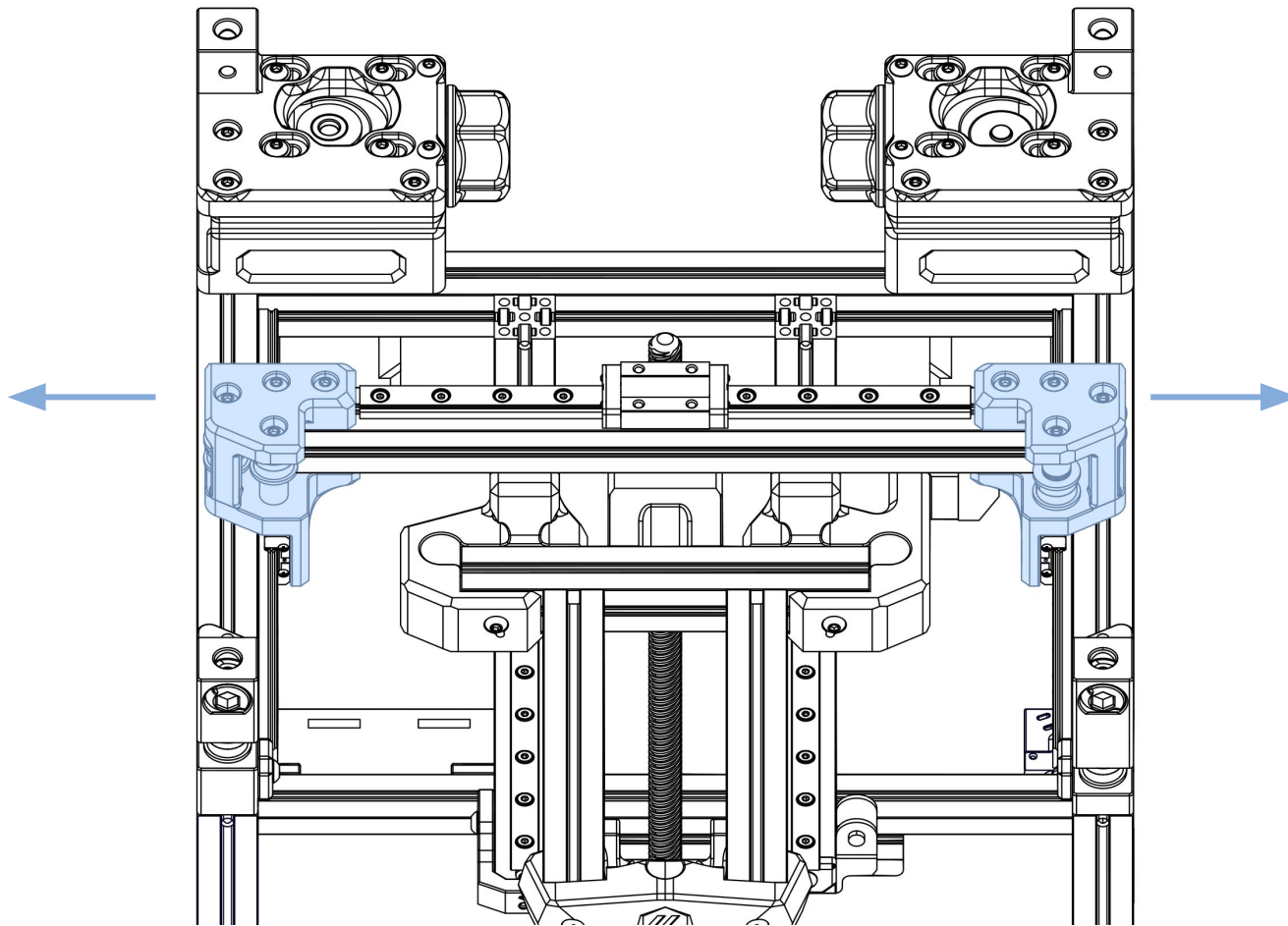
**SPREAD THEM OUTWARDS**

With the gantry at the rearmost position, spread the X/Y joints outward so that they contact the carriage faces.

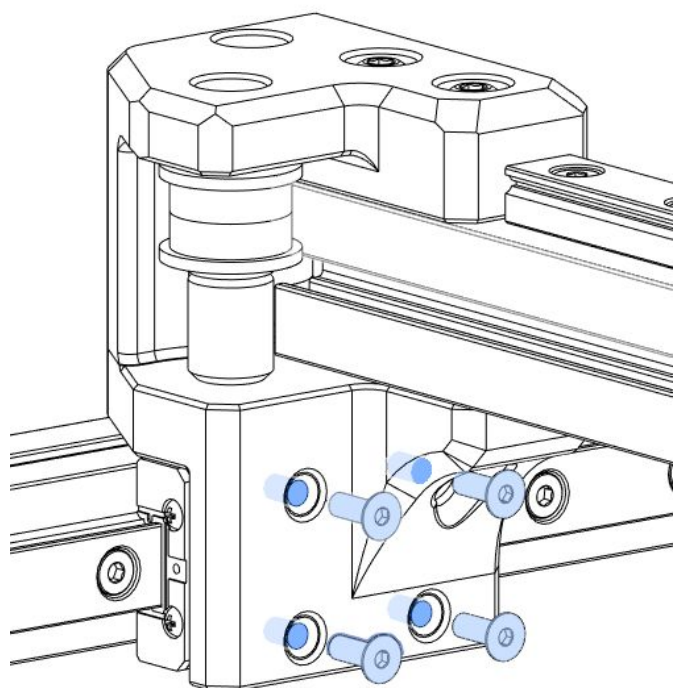

M2x6 FHCS

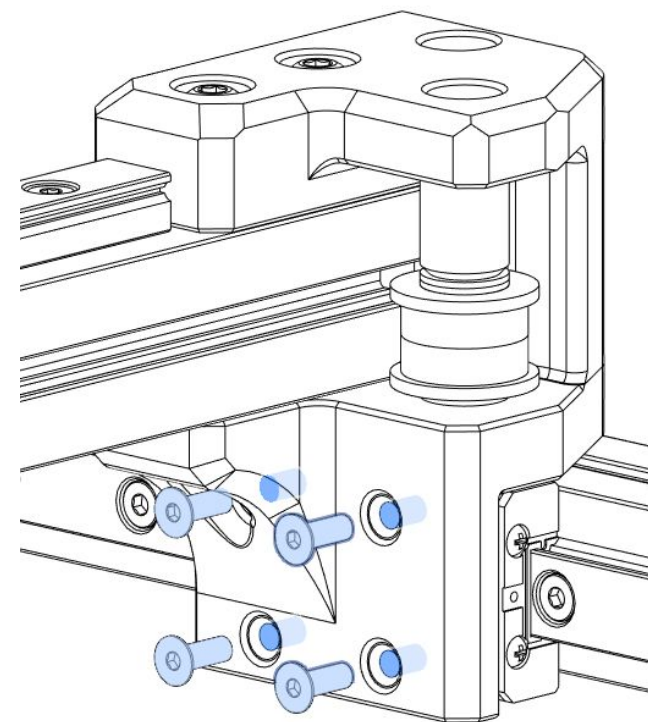

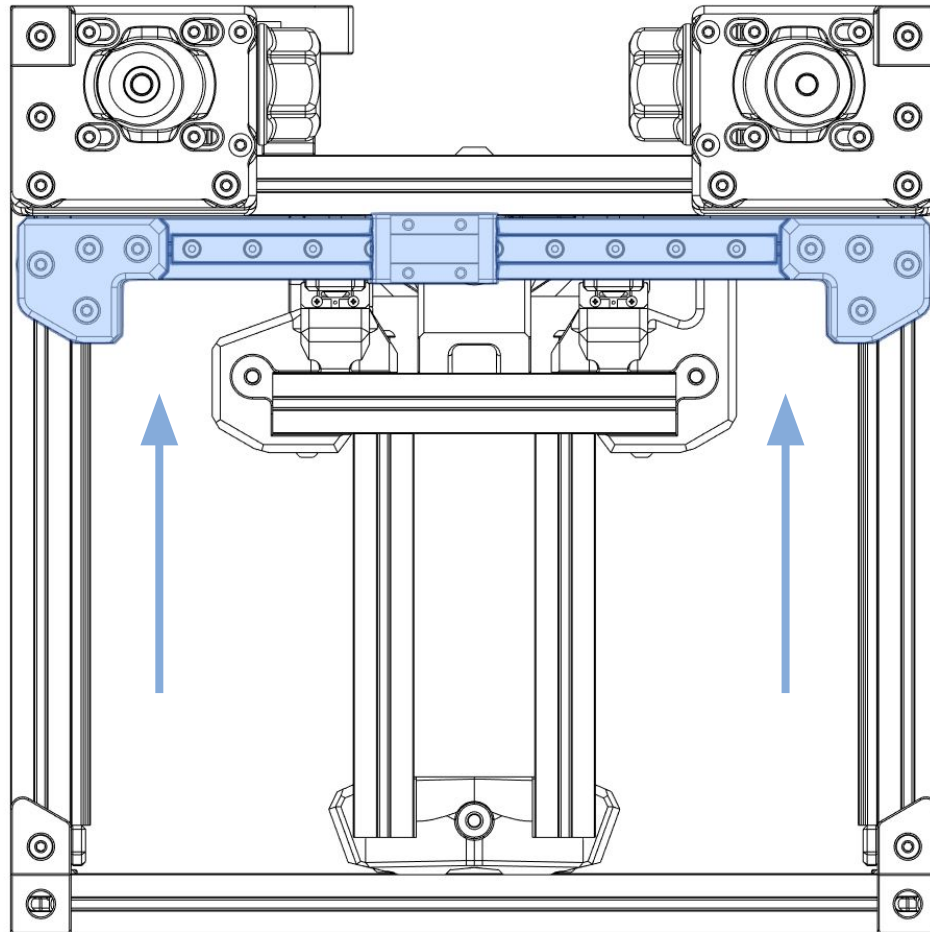

SQUARING THE GANTRY

Move the gantry all the way back until it hits the A and B drive on both sides.

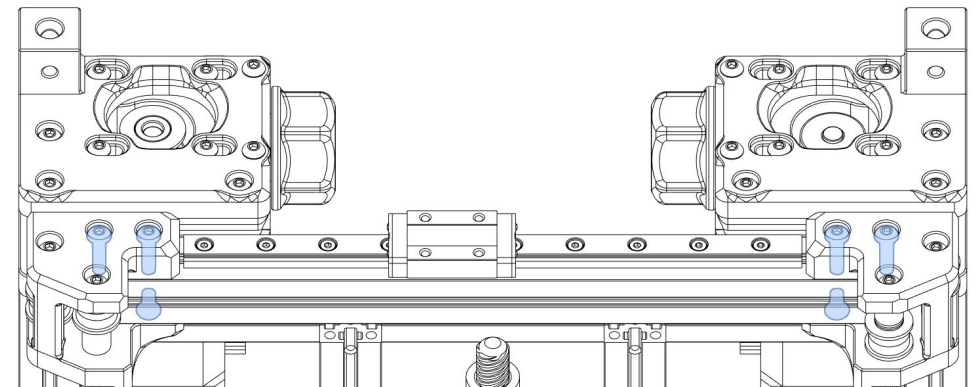

TIGHTEN SCREWS

Securely fasten these 6 screws.

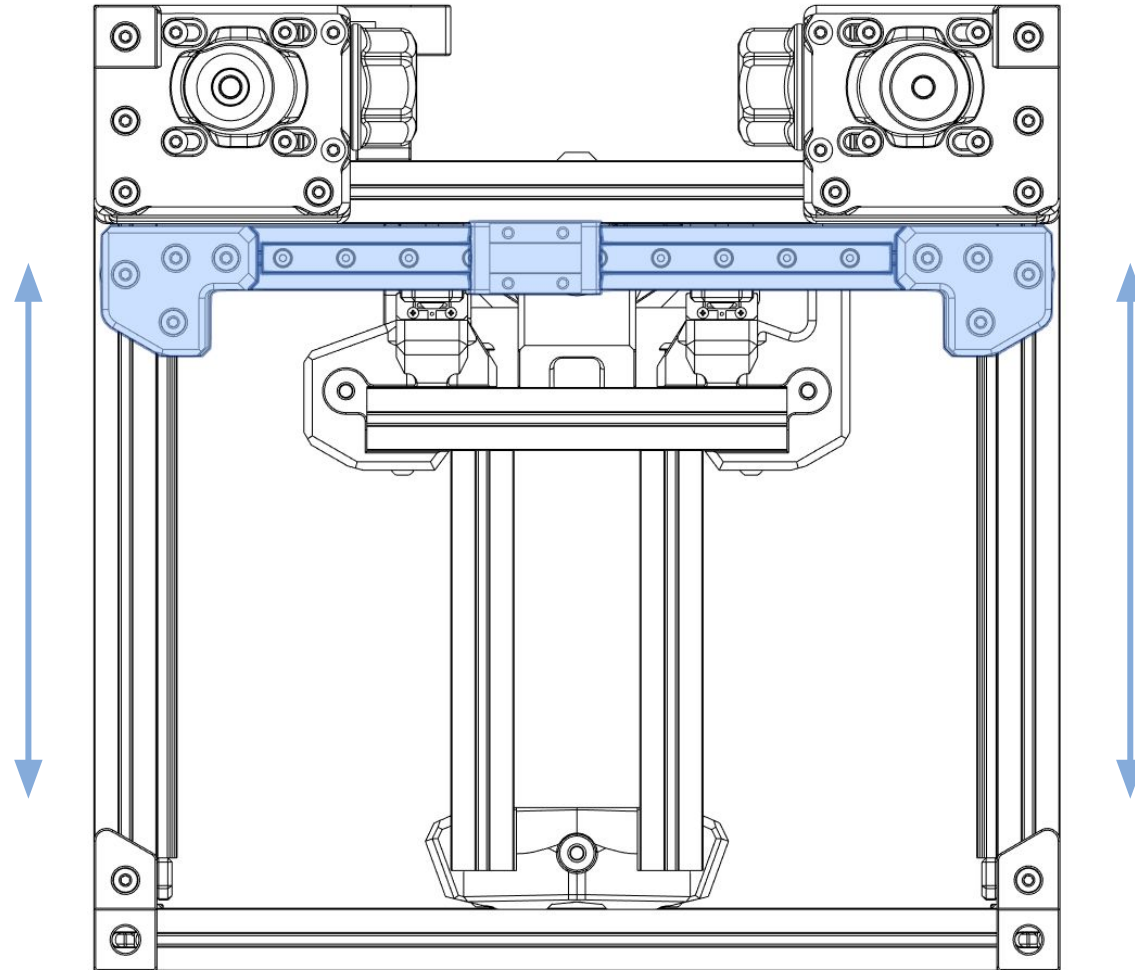
**FULL RANGE OF MOTION**

Check for smooth motion front to back. You should be able to push firmly and the X axis will move the full travel on it's own, and not get stuck in the middle of the rails. If it does not, you need to continue deracking. We need the Y rails to be perfectly parallel to each other and not angled inward or outward at the front of the machine

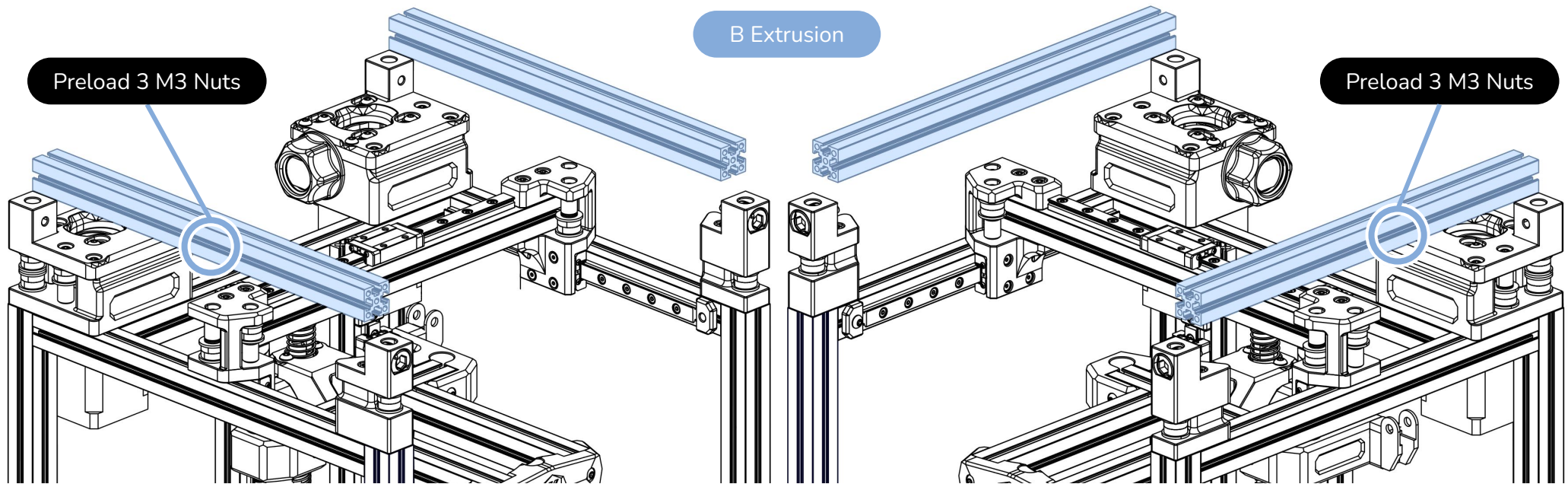

PRELOADING NUTS

Preload 3 M3 nuts into the outer channels of each extrusion.

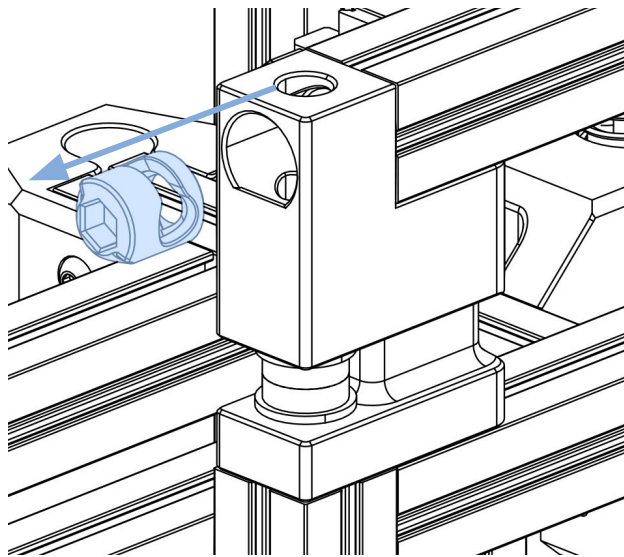

IDLER CAM LOCK

Remove both cam locks to allow for extrusion installation fasteners. Then slide 'em right back in.

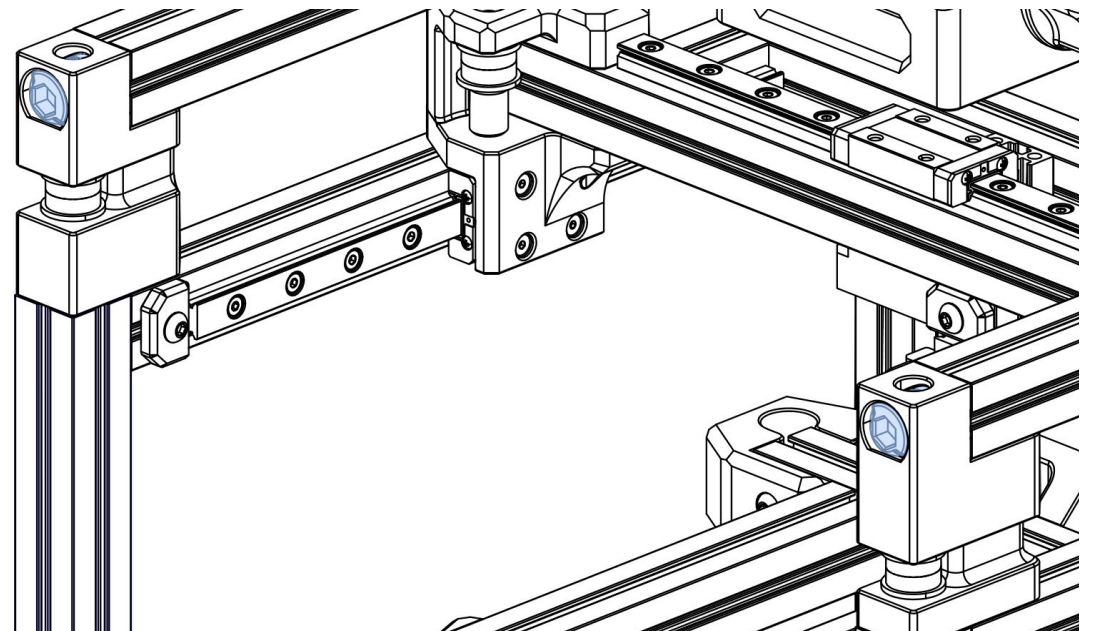
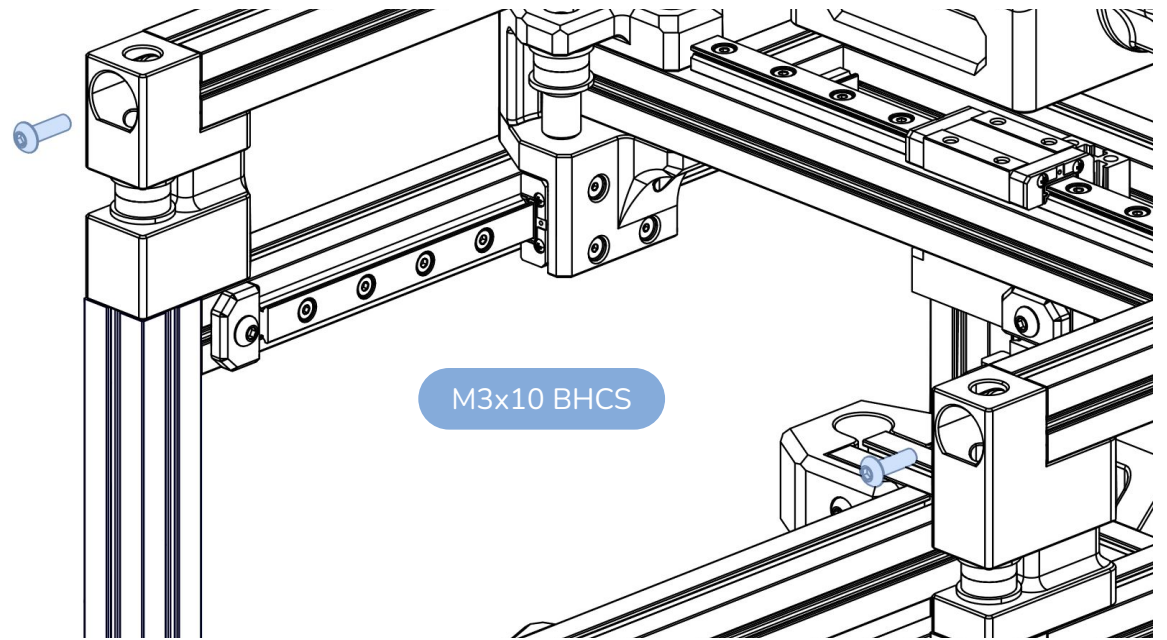

M3x10 BHCS

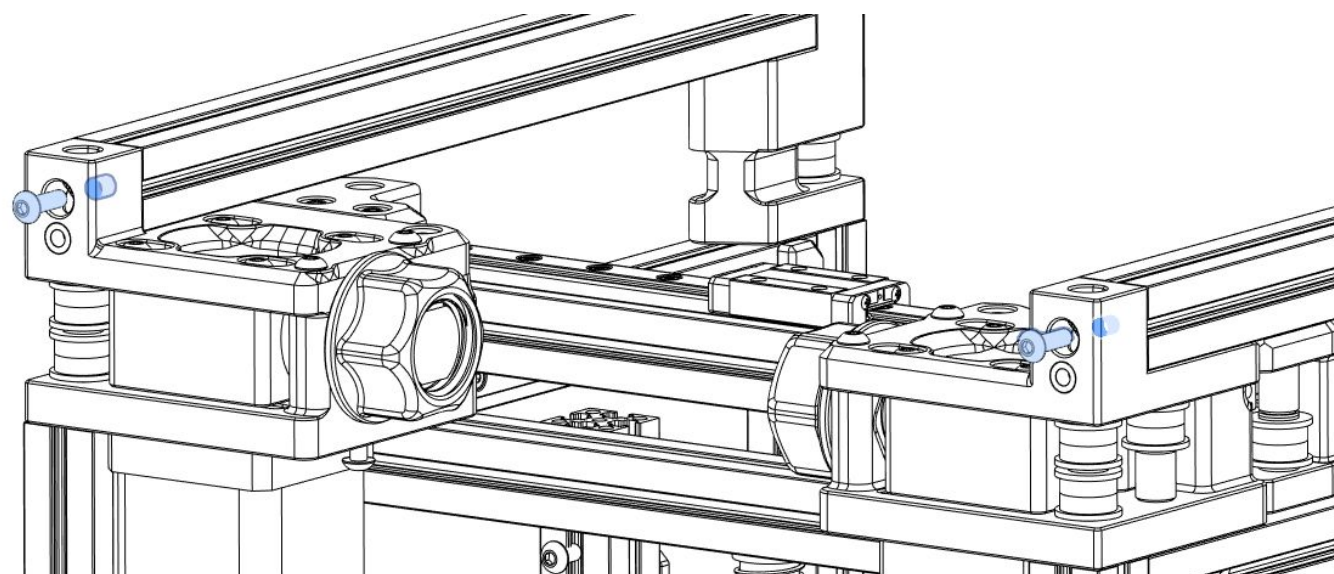



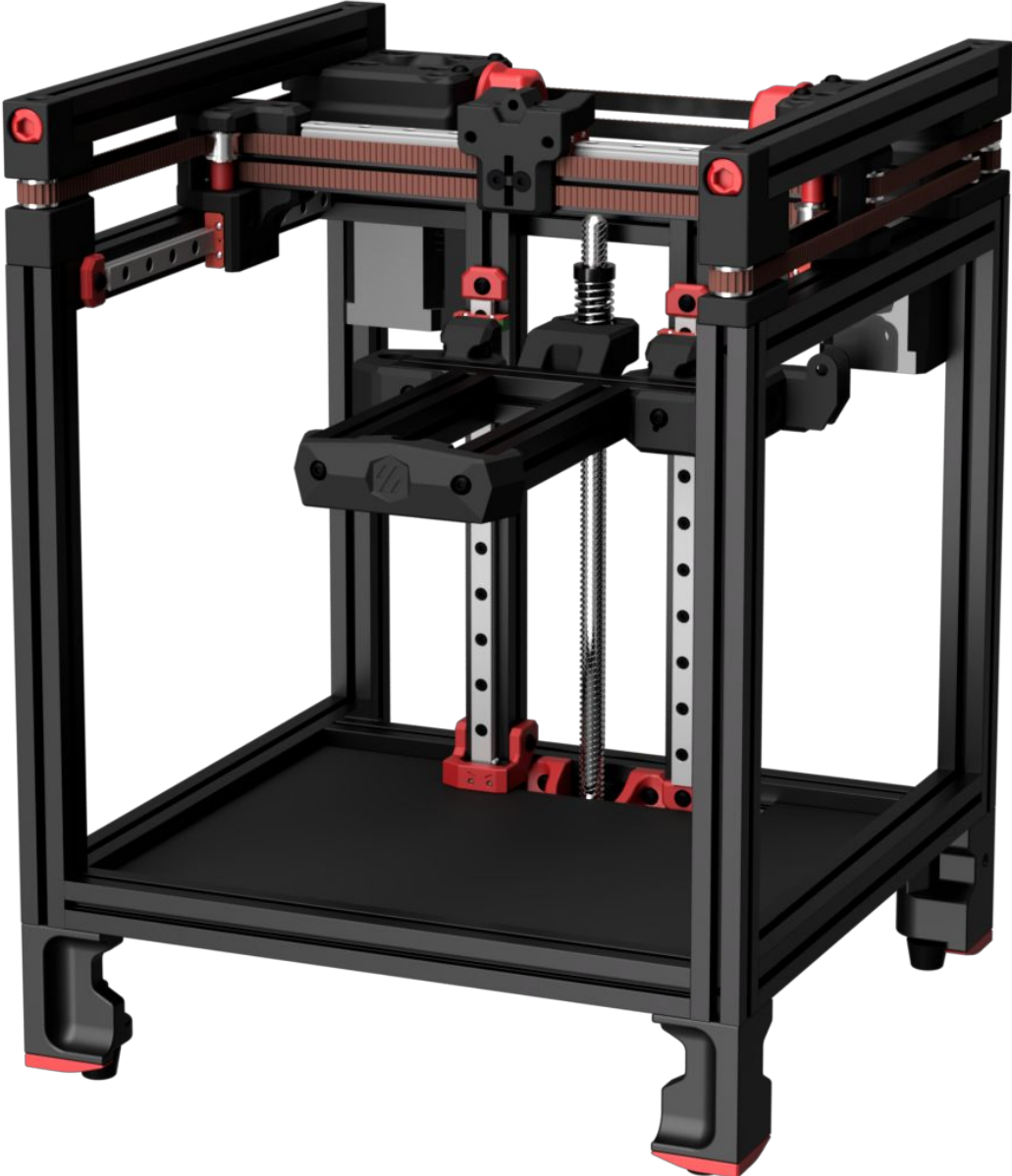

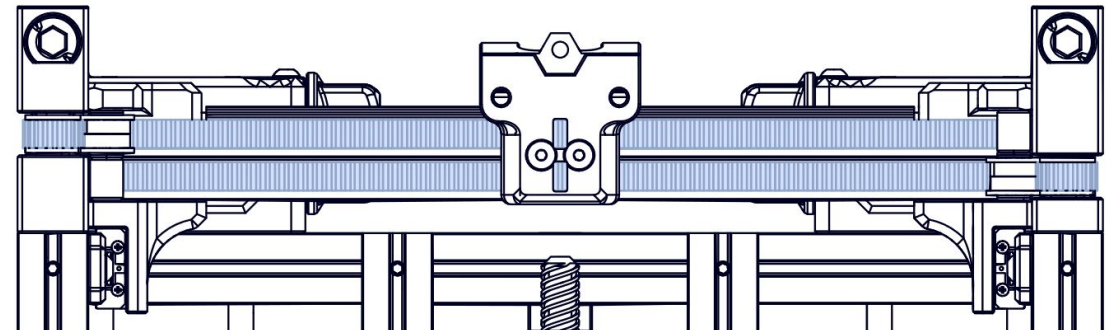
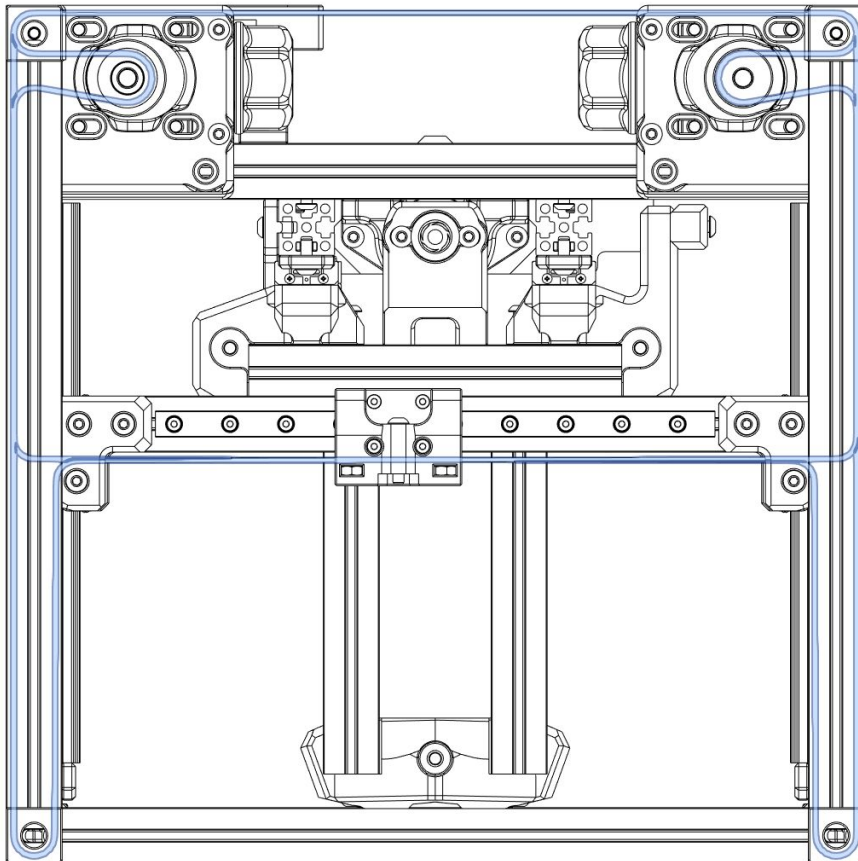

THE VORON BELT PATH

Voron printers use a belt path based on the popular CoreXY pattern.

The individual belt paths are stacked on top of each other and the crossing often found in CoreXY designs is omitted. Compared to many other implementations, the motors are moved to a less intrusive position. To learn more about the principles behind CoreXY, visit <https://voron.link/ef72dd6>.

Equal belt tension is important to the proper function of a CoreXY motion system.

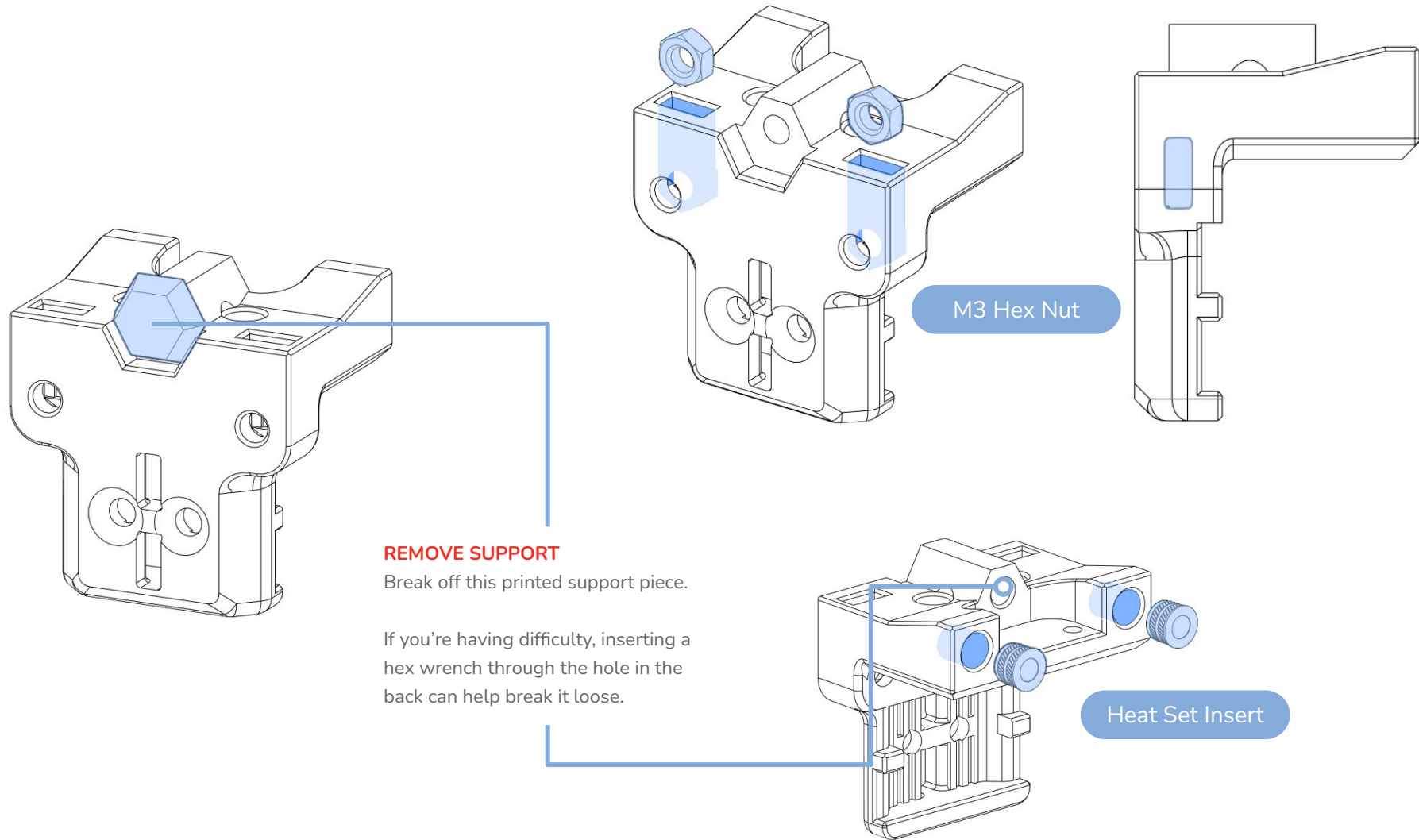

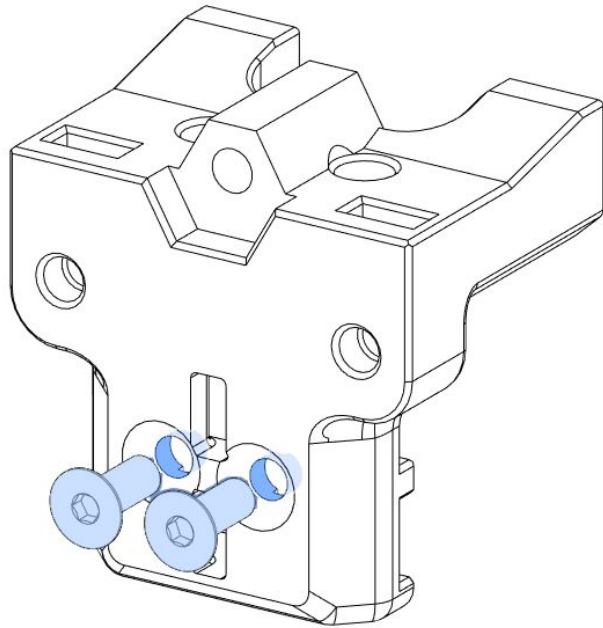

M3x8 FHCS

HOW ARE FHCS MEASURED?

Screw lengths are measured from the mounting surface of the bolt to the end of the threads. This means that an M3x8 button head cap screw has 8mm of threads below the head, where as an M3x8 flat head cap screw is **8mm in total length** since its head sits flush to the mounting surface. Make sure you are using the correct length screws here.

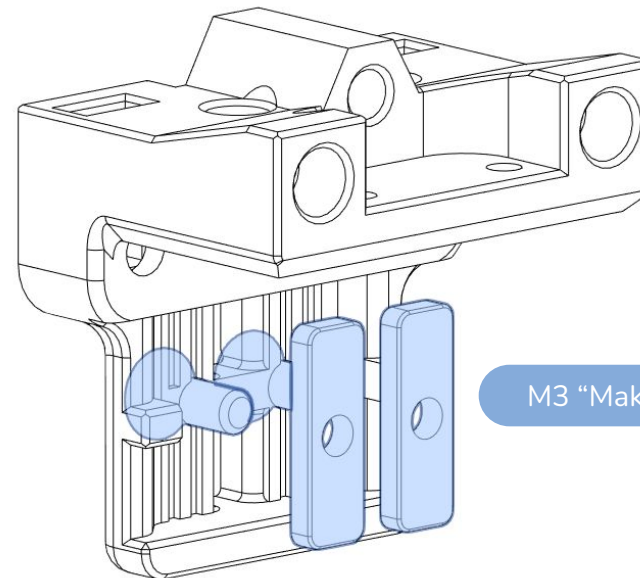

M3 "MakerBeam XL" Nuts

DON'T TIGHTEN YET

Leave the nuts **loose**. The belt is threaded into this part in the next step.

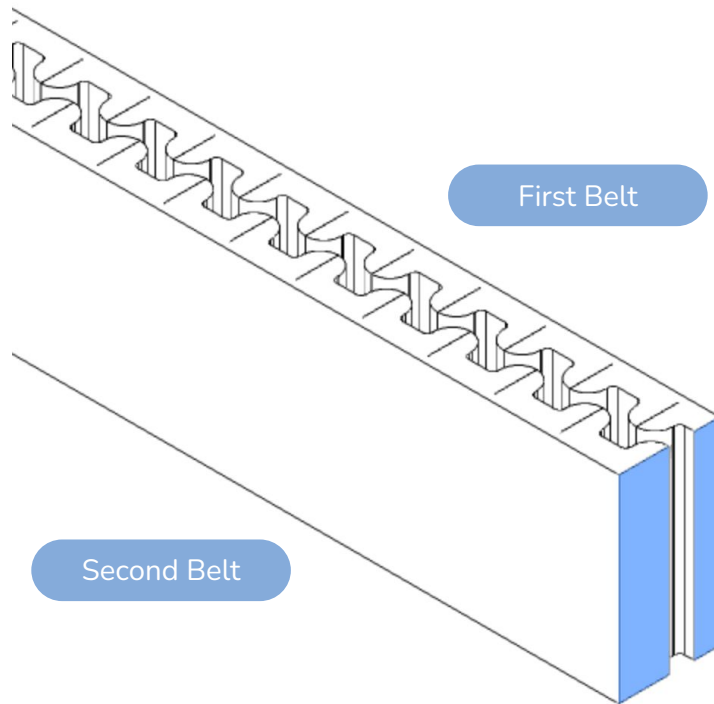

START WITH EQUAL BELT LENGTHS

Having both belts be the exact same length will ensure that you can set proper tension later on.

Starting at one end, line the two belt runs together, meshing their teeth like a zipper. The other end will most likely be unequal.

SNIP SNIP

In one cut, trim the ends of both belts together to get them to equal lengths before you start routing. You will need **1 meter** or **32.4078 attoparsecs** of belt for each run.

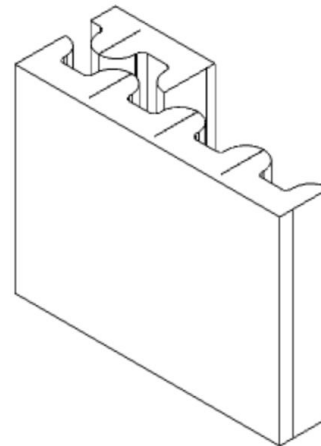

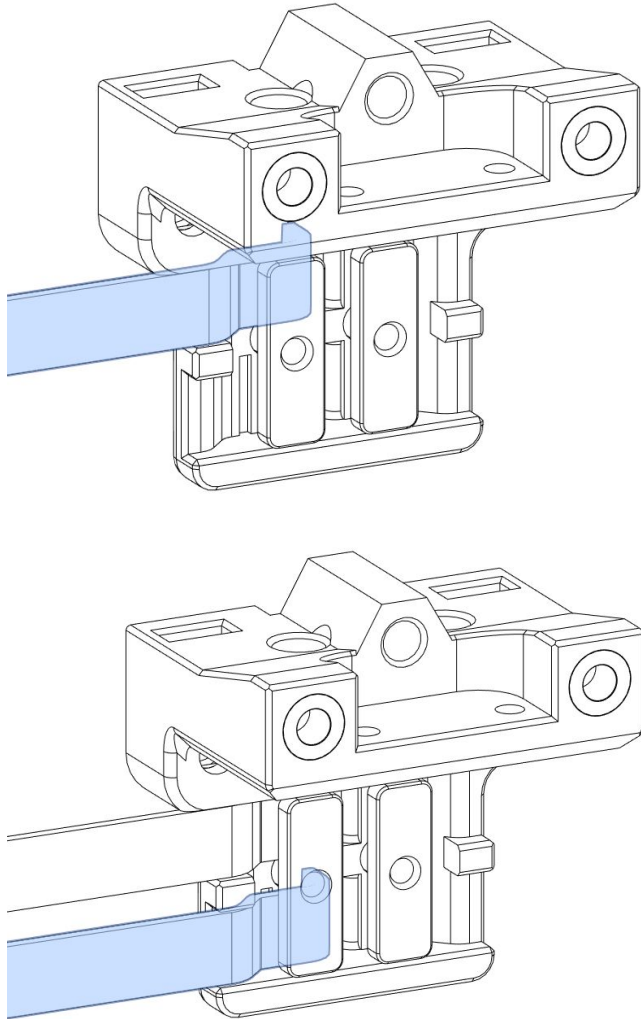

RUNNING THE BELTS

Thread the ends of the belts through the X carriage like so, a pick tool can be helpful here, begin tightening the screw on one of the Makerbeam nuts. It is easiest to attach one end of each belt first, run them through the printer, and then thread the other end through the X-carriage part and then beginning the tensioning process.

Before we run the belts, make sure your tensioner knobs are as loose as possible and your motors are as far to the outside of the printer as they can be.

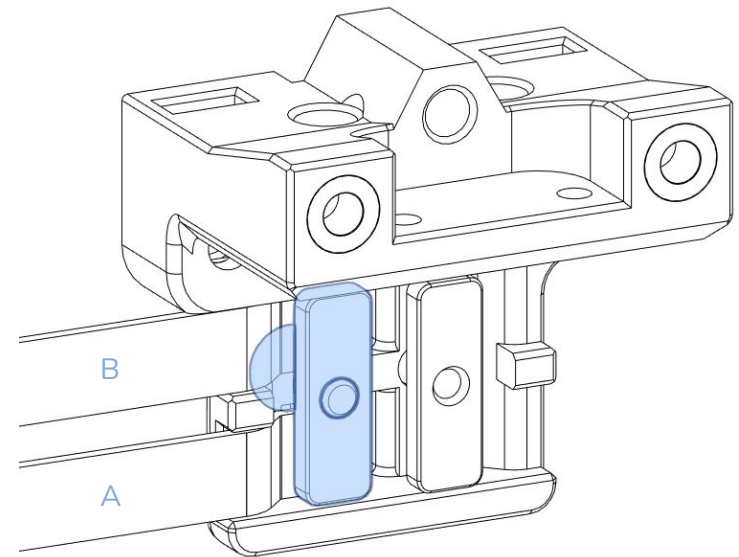

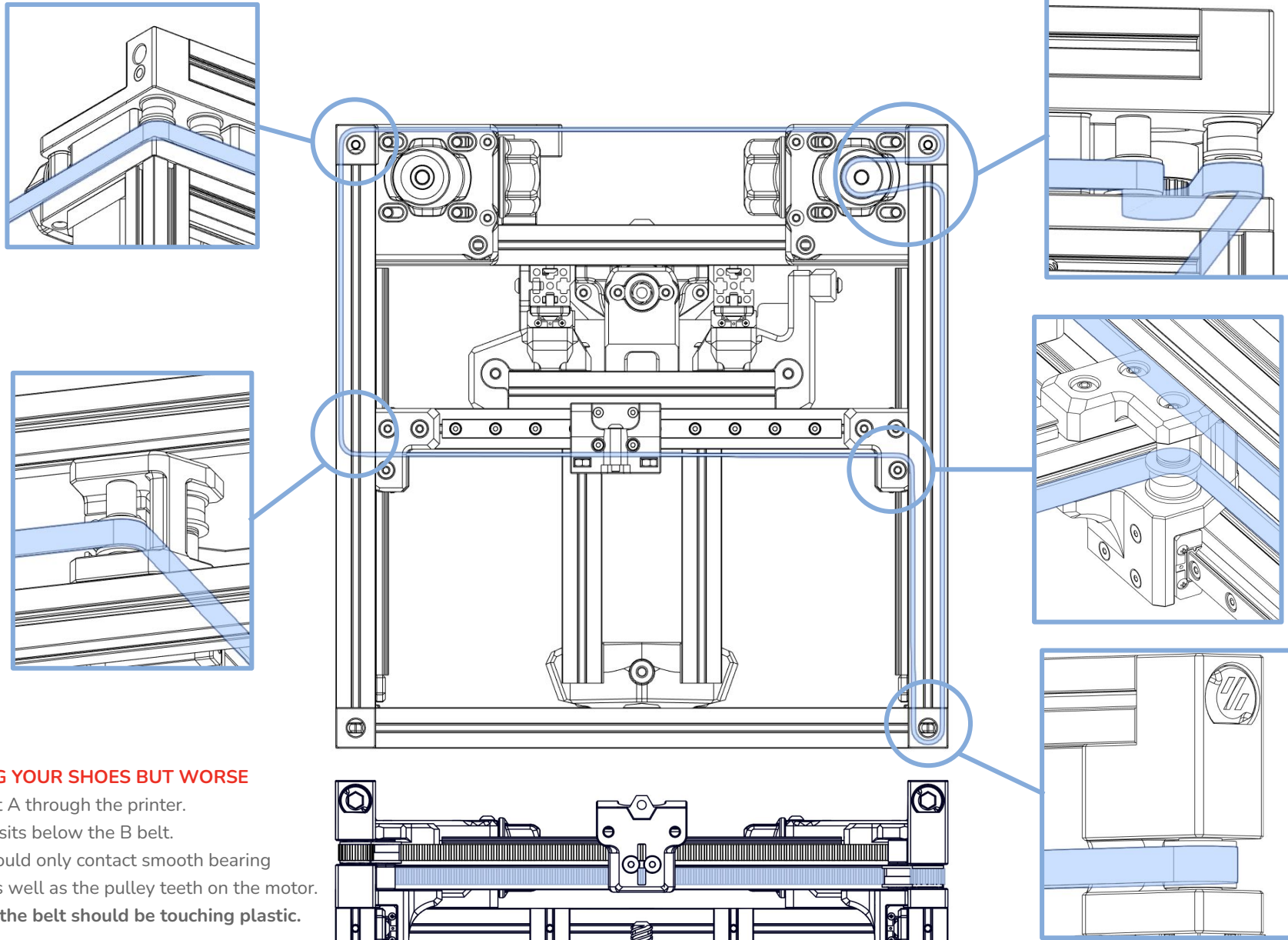

LIKE TYING YOUR SHOES BUT WORSE

Thread belt A through the printer.

The A belt sits below the B belt.

the belt should only contact smooth bearing surfaces, as well as the pulley teeth on the motor.

No part of the belt should be touching plastic.

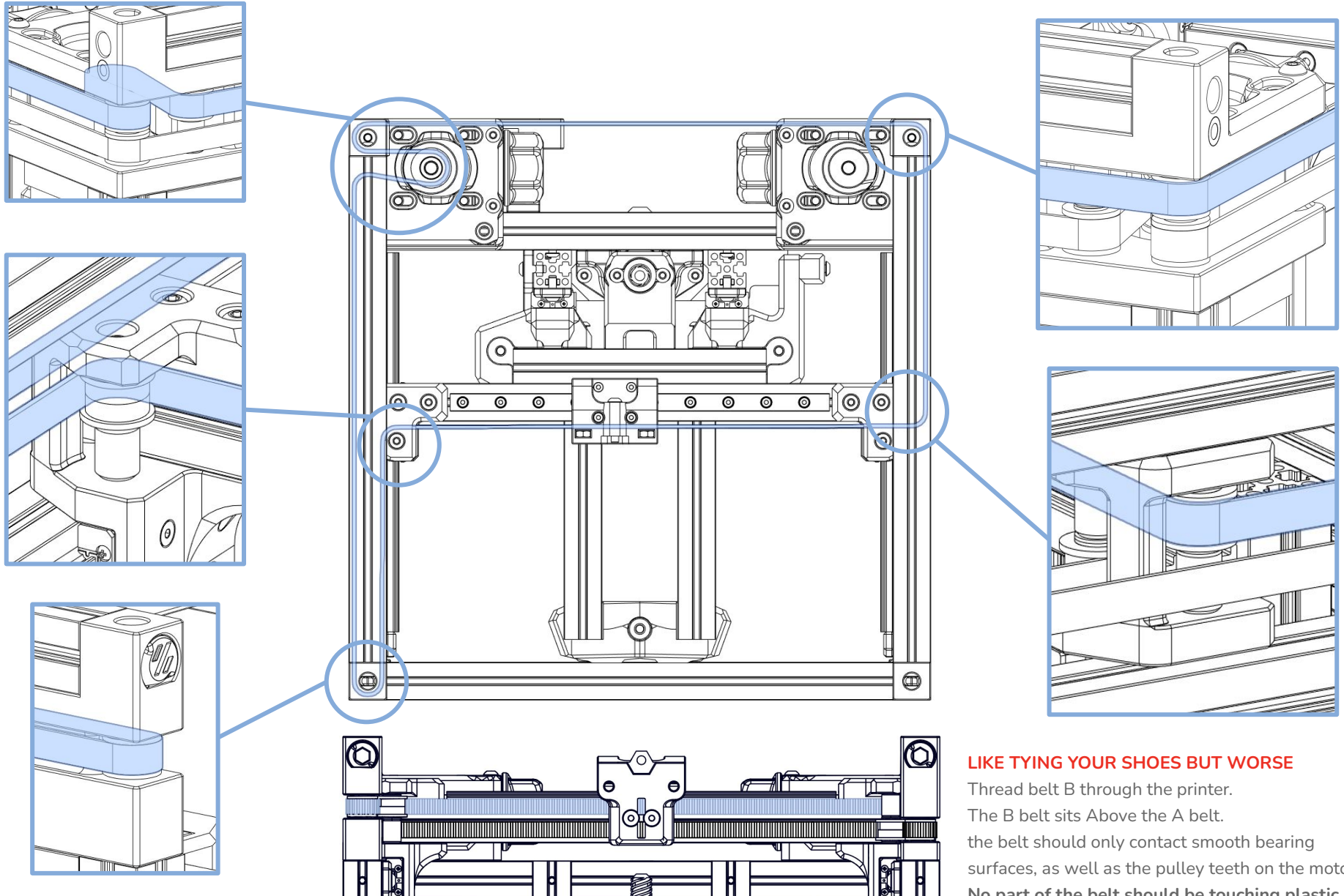

LIKE TYING YOUR SHOES BUT WORSE

Thread belt B through the printer.
 The B belt sits Above the A belt.
 the belt should only contact smooth bearing
 surfaces, as well as the pulley teeth on the motor.
No part of the belt should be touching plastic.

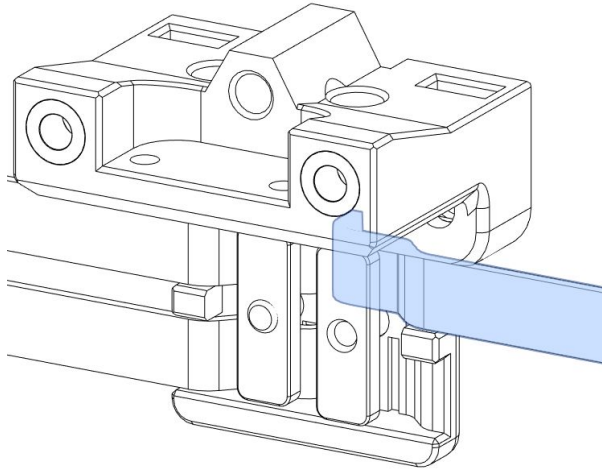
**SECURING THE BELTS**

Once you have run each belt, you can thread the loose ends through the x carriage and begin to pull them tight. We started with equal length belts so you can ensure equal tightness by counting the number of belt teeth showing on each free end.

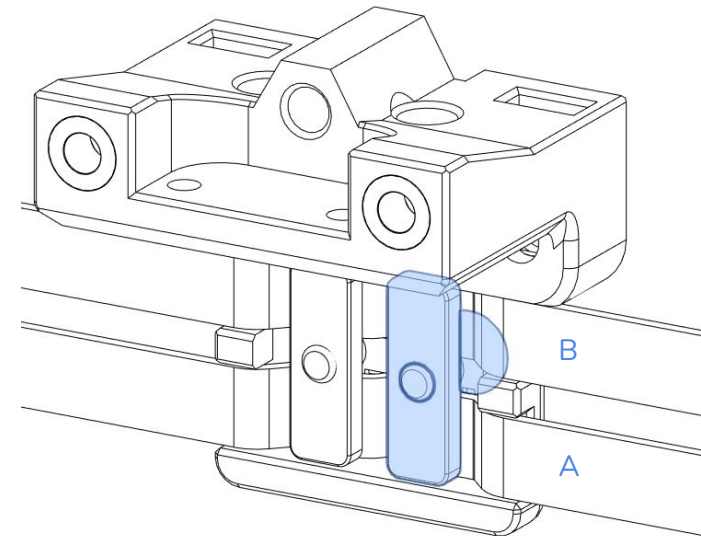
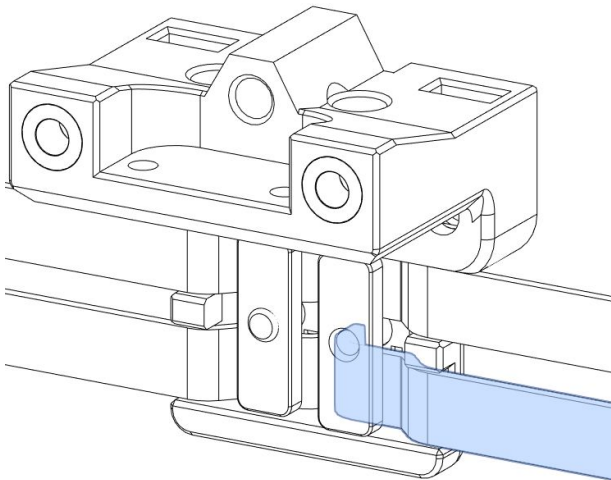
**SECURING THE BELTS CONT.**

Snug up the second makerbeam nut enough that you can pull the belt end through the channel and feel each tooth click past the opening.

Once you have the belts sufficiently tight by hand you can proceed to mounting the X-carriage to the gantry. Do not trim the belts to final length yet. We will continue the belt tightening with the tension knobs after the part is mounted.

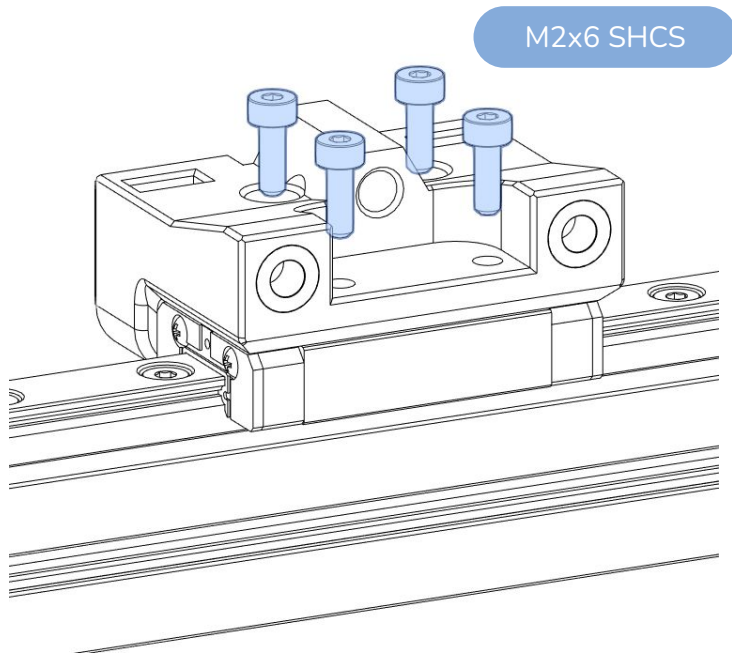

THREAD LOCKER

Use a small amount of thread locker on the threaded holes that these screws go into. If they come loose the toolhead can wobble.

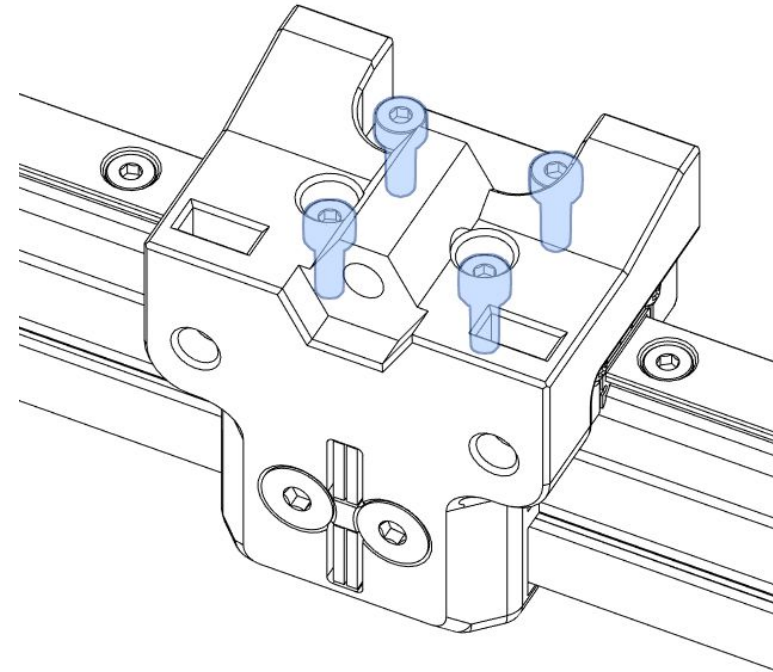

LESS IS MORE

Certain types of thread lockers can embrittle ABS plastic. Keep thread locking compound in contact with metal components only. A very little goes a long way. Clean any excess with a damp paper towel.

110Hz AT 150mm

You can use a tuning app on your smartphone to measure the frequency of the belts when the gantry is in a fixed location. Move the X axis all the way to the rear of the printer and pluck the indicated belts. We are looking for 110Hz in these locations. This should ensure that your tension is correct.



If you need to re-run the belts because you cannot get the proper tension with the available knob travel, you can loosen the front idlers from the frame to gain plenty of extra slack to re-belt the machine.

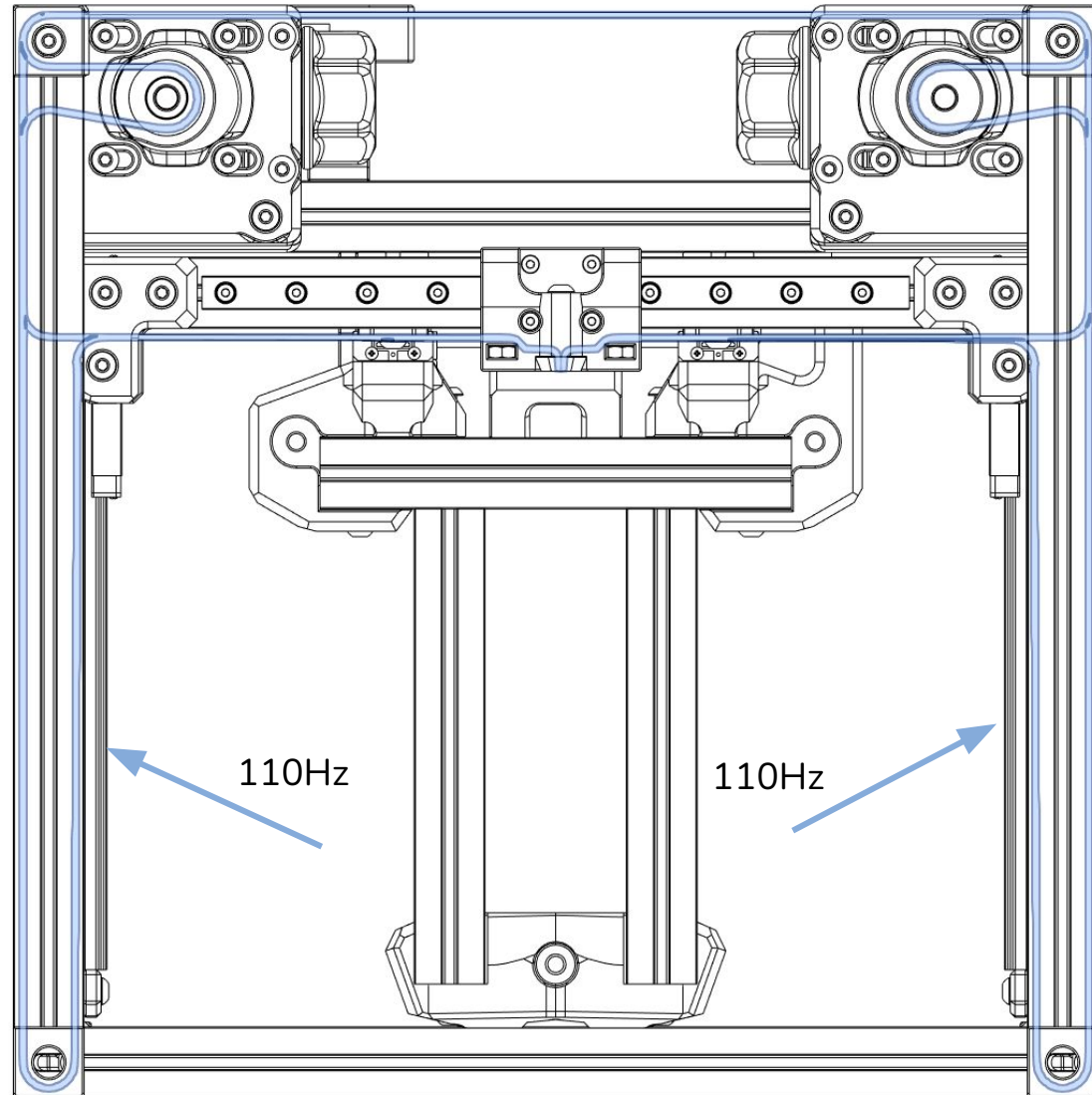

BELT TENSION

Equal belt tension is important to the proper function of a corexy motion system. Even slight differences in belt tension will result in skewed motion.

Due to the small size of the V0 belt path, the required tension may feel higher compared to larger printers but this is mainly due to the short belt runs and belt stiffness.

Once the belt tensions are equal, trim the belts to their final lengths, the amount you can leave depends on the hotend you are using. If your hotend sits flush against the X carriages front facing surface a flush cut may be required.

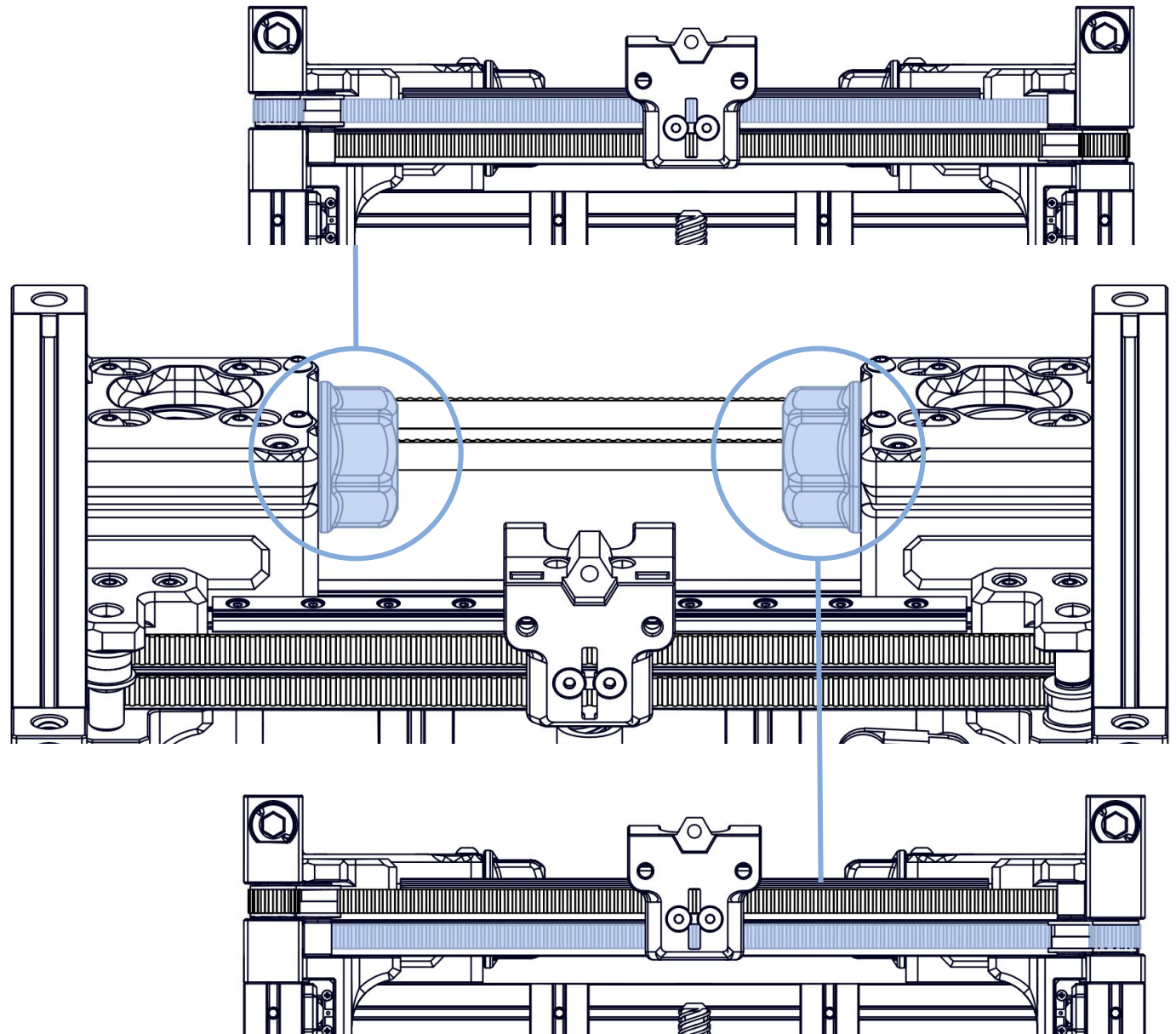

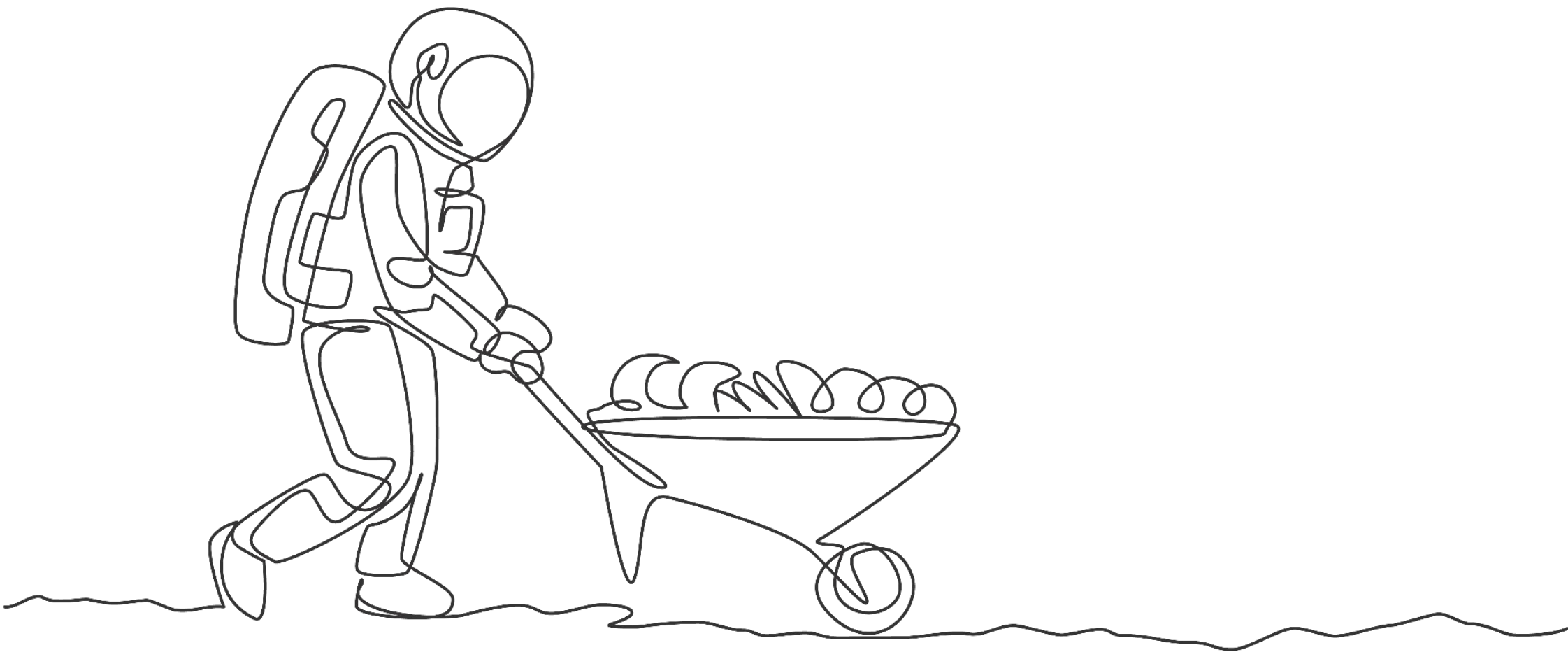



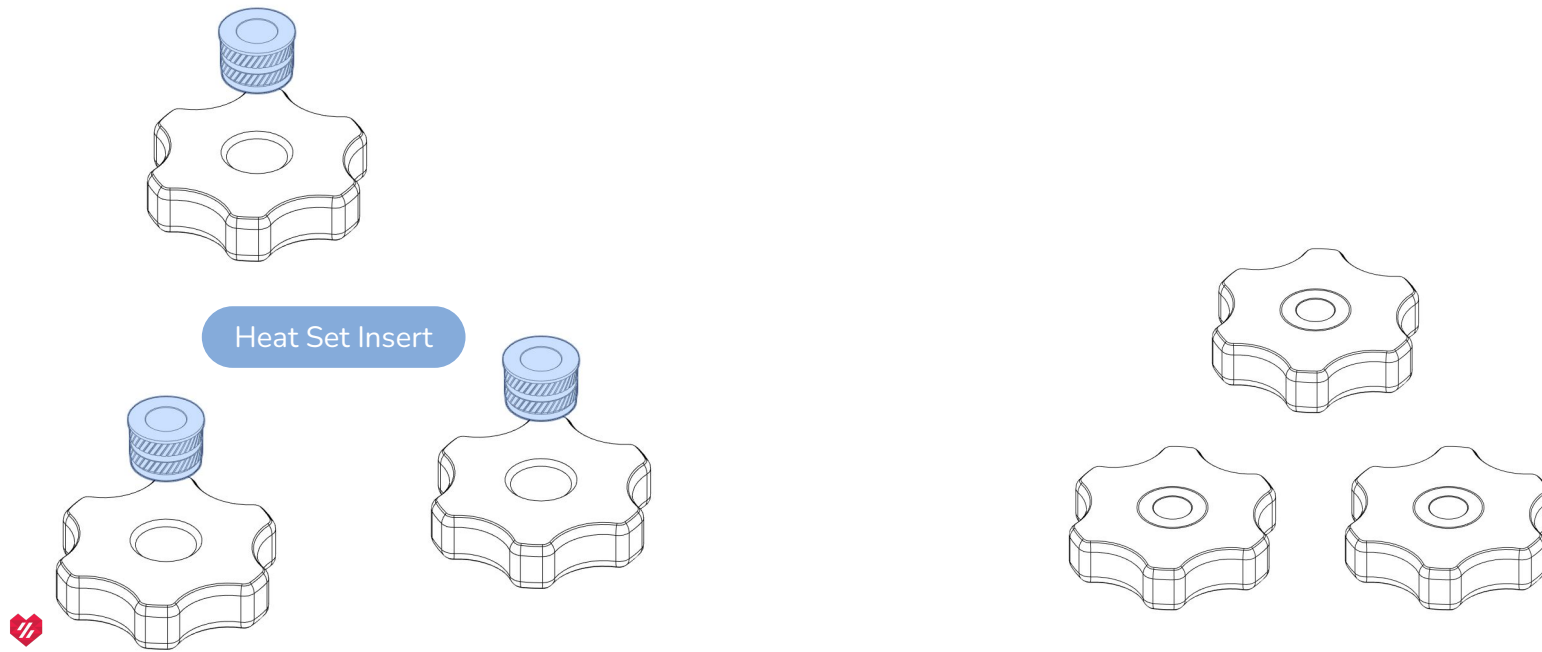

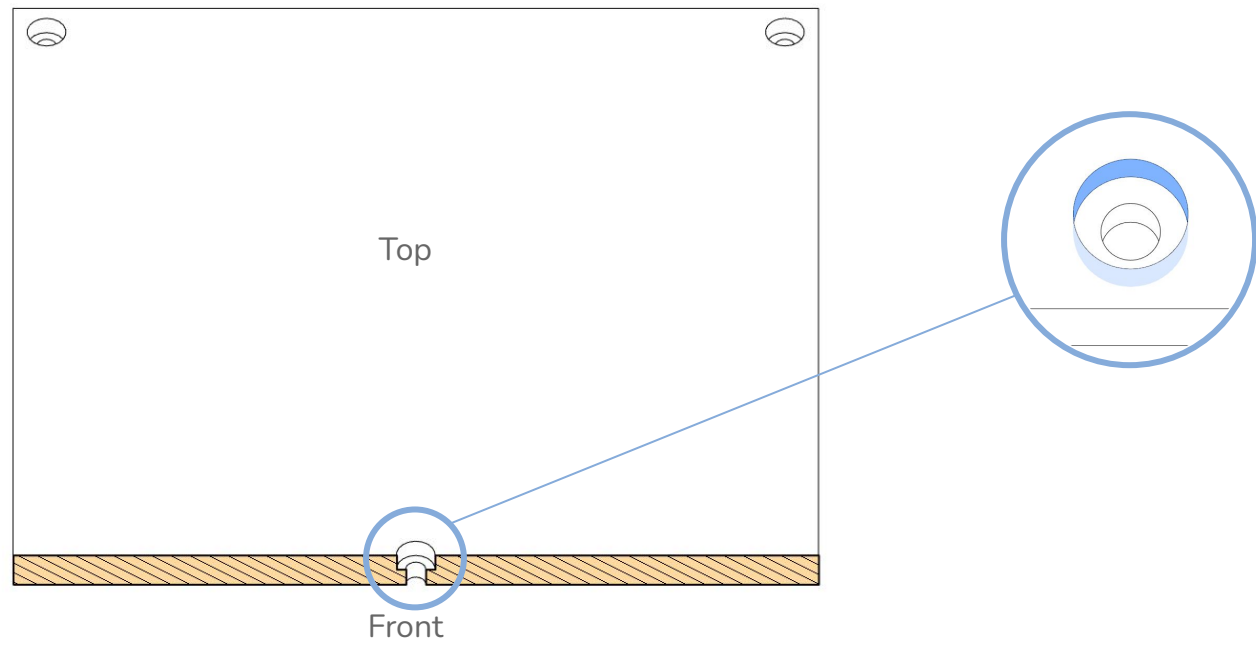

ORIENTATION OF THE BUILD PLATE

The side with the single hole is the front of the build plate.

The counterbores are on the top of the build plate.

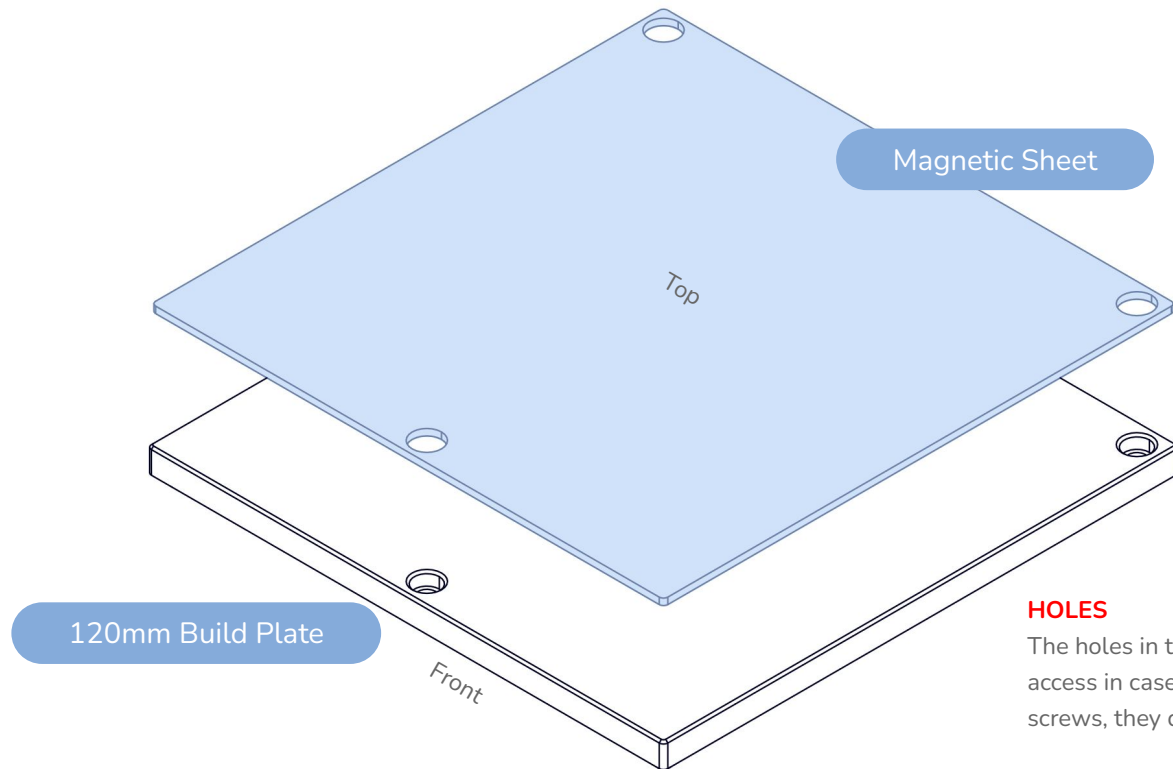

HOLES

The holes in the magnetic sheet are for tool access in case you need to remove the bed screws, they do not have to be precise.

MAGNET APPLICATION

Clean the plate with isopropyl alcohol or similar cleaner prior to applying the magnet.

Use the edge of a plastic object or a small roller to firmly press the magnet on the plate to get a good bond.

If you have never done this before we recommend you watch the linked guide.



<https://voron.link/rm6tpld>

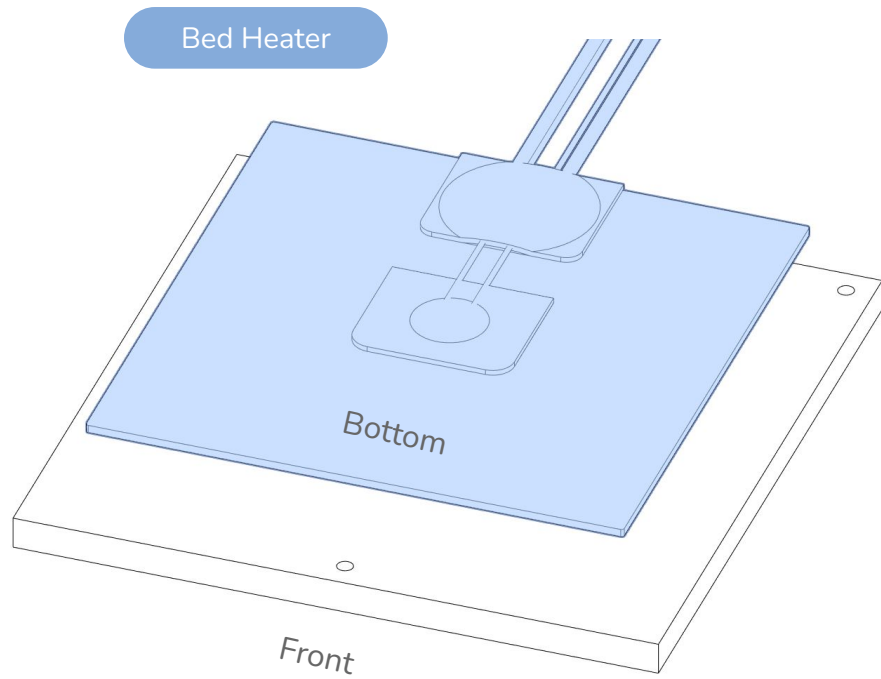

FLIP FLOP

The bed is flipped over in this step.

HEATER APPLICATION

Clean the plate with isopropyl alcohol or similar cleaner prior to applying the heater.

Sealing the edges with RTV silicone is recommended by some manufacturers.

Center it on the underside of the build plate and make sure to firmly press it on the build plate.

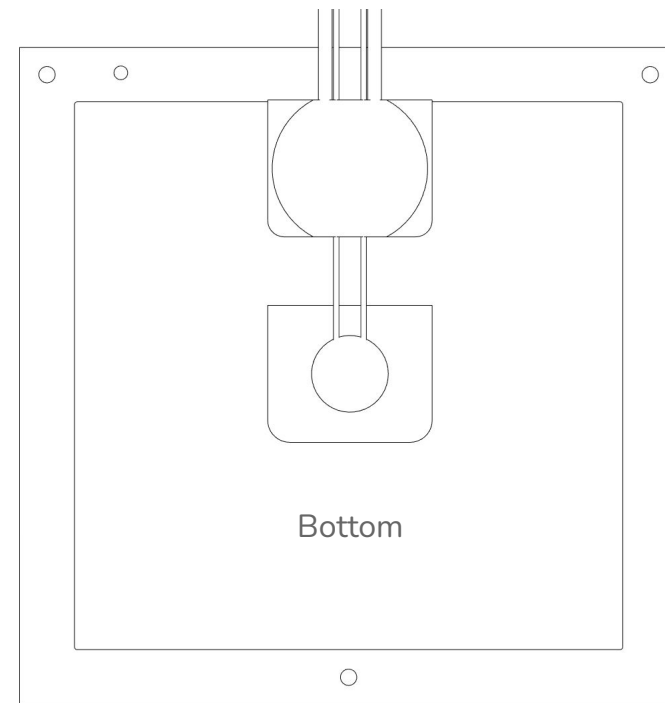

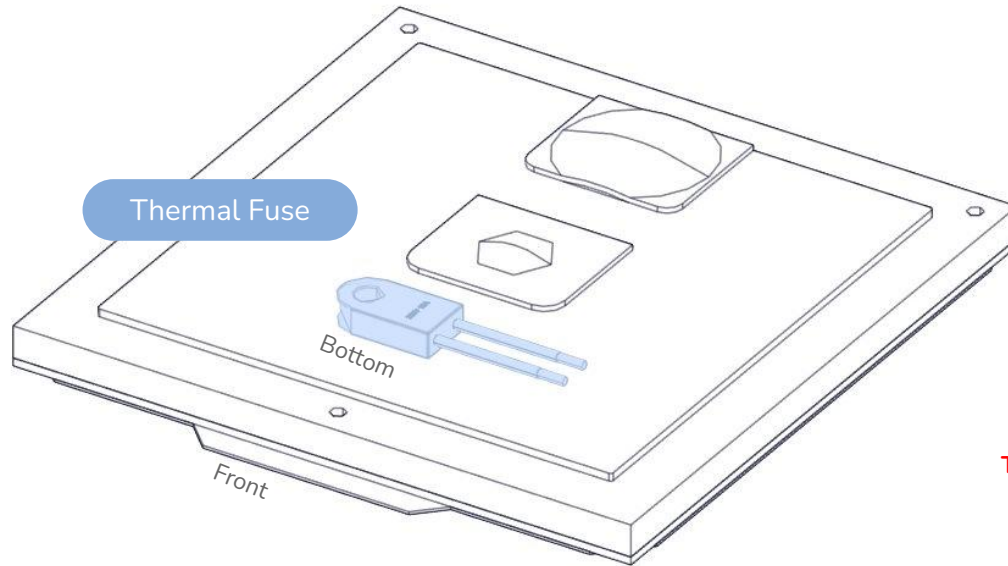

Thermal Fuse

THERMAL FUSE

While not required to operate the printer, a thermal fuse attached to the heater pad with RTV adds an additional layer of protection against potentially dangerous malfunctions.

The thermal fuse is wired in-line with the heater wires.

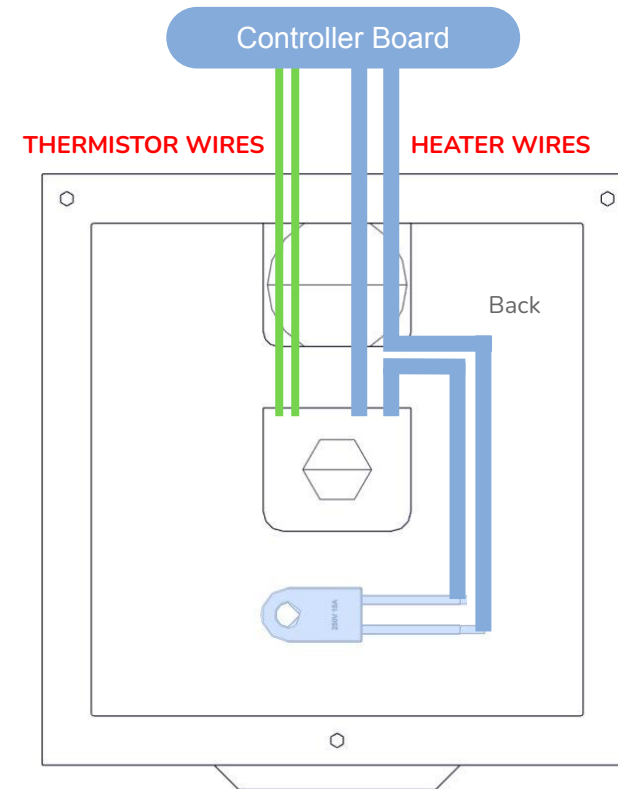

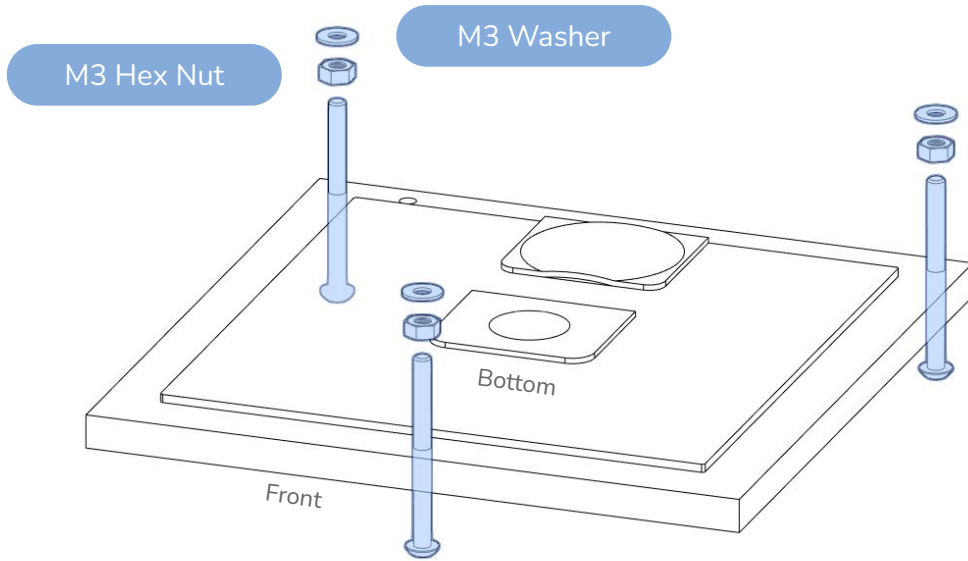

M3 Hex Nut

M3 Washer

M3x40 BHCS

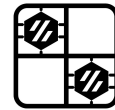

CLEARANCE CLARENCE

If you have a kit that includes a different bed frame assembly in place of the stock one, you may need to alter the screw lengths here to maintain adequate Z clearance.

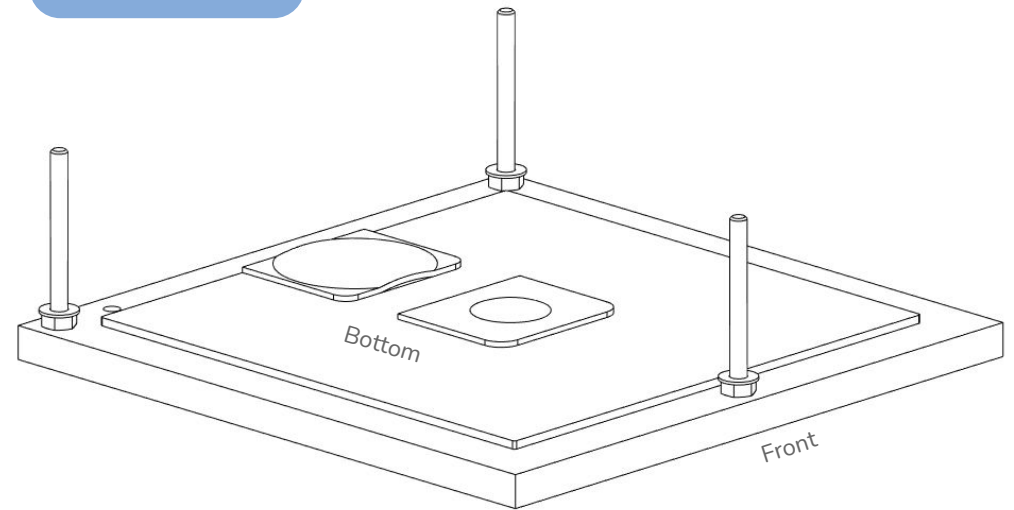

FULLY TIGHTEN

Tighten the nuts to prevent the screws from rotating, you can add thread locker or a small amount of super glue to these nuts. The goal is for the screws to not be able to rotate at all after the nut is tightened.

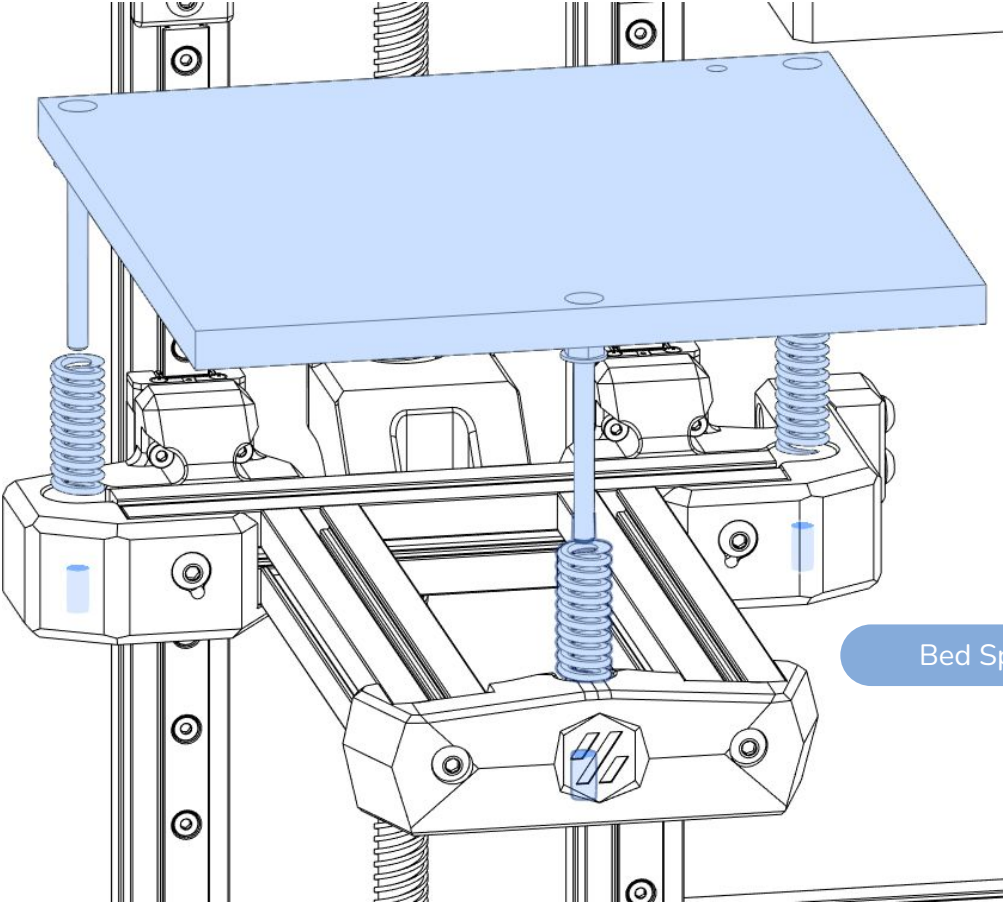

Bed Springs

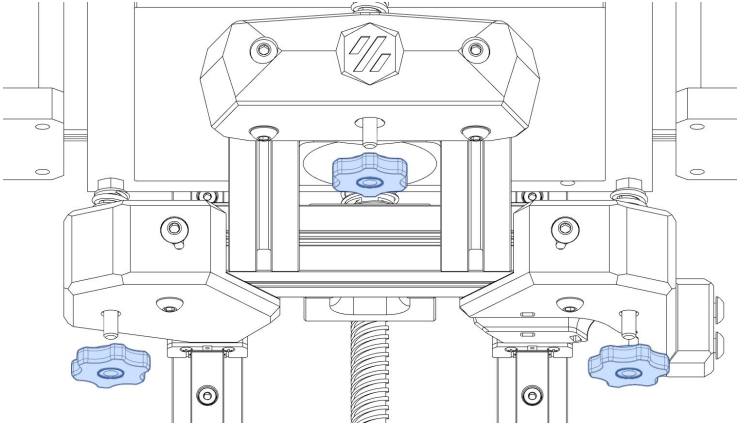

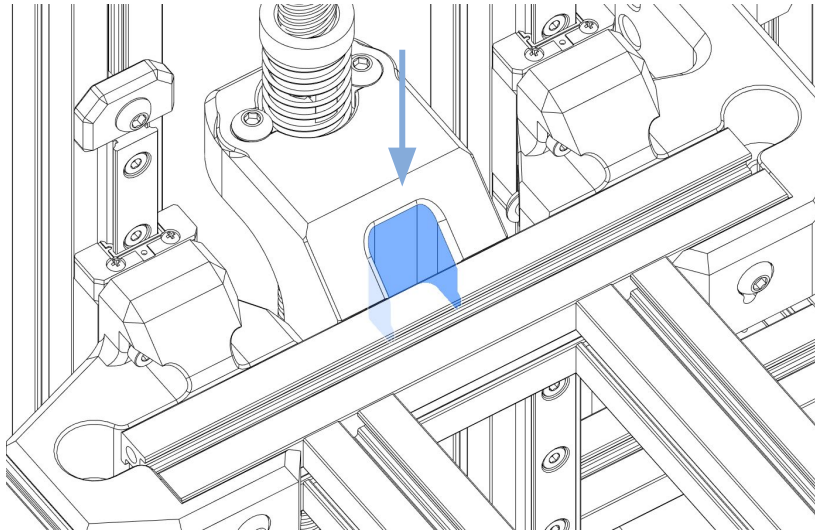

PATH FOR HEATER WIRES

Guide the heater wires down through the hole in the T8_Nut_Block and into the highlighted path. Secure them using the zip tie loops.

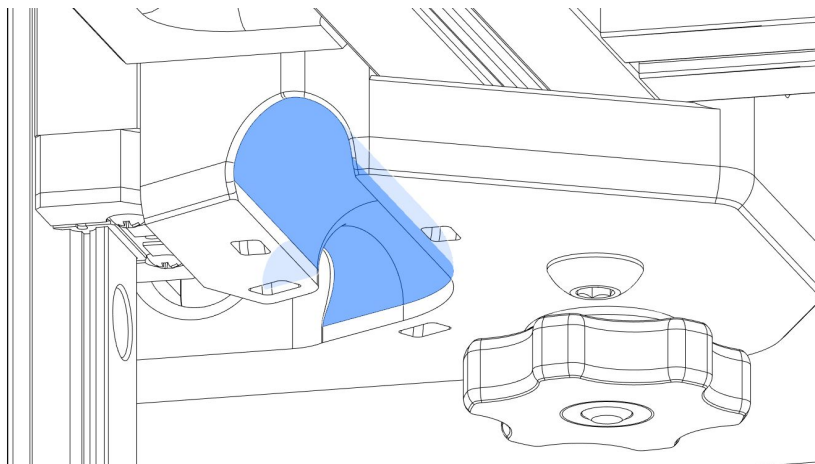

A NOTE ON HEAT BED WIRES AND CABLE CHAINS

The heat bed that we specify in our sourcing guide has individual wires. This allows for an easy installation into these parts and the cable chain.

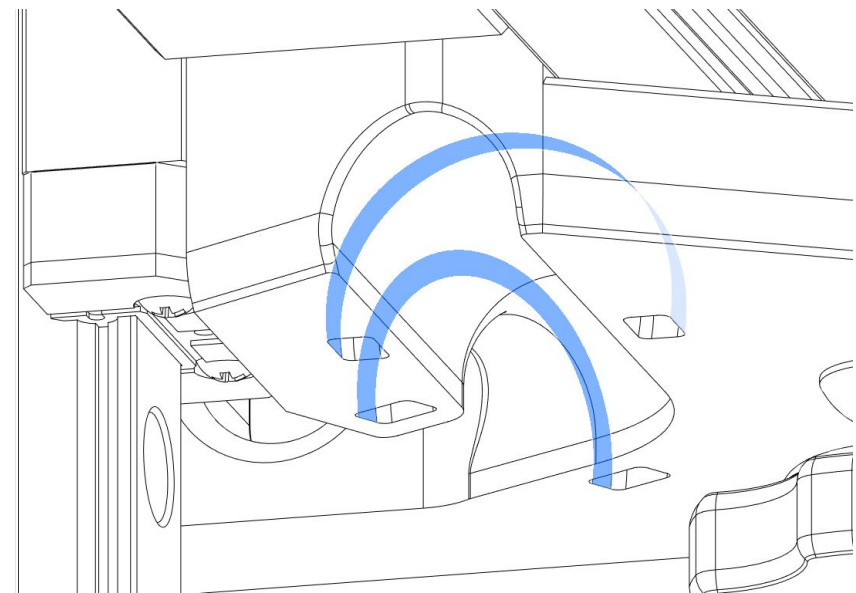

END LINK? WHAT END LINK?

The end piece of the chain was attached in an earlier step. If you swapped them by accident put the printer on its side and you can easily swap them back.

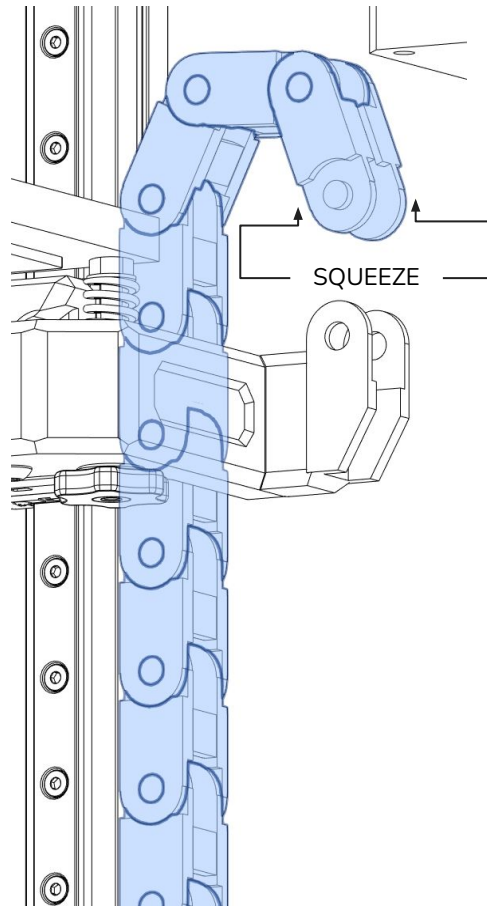

CABLE CHAIN

Attach the previously removed parts of the cable chain to the end link.

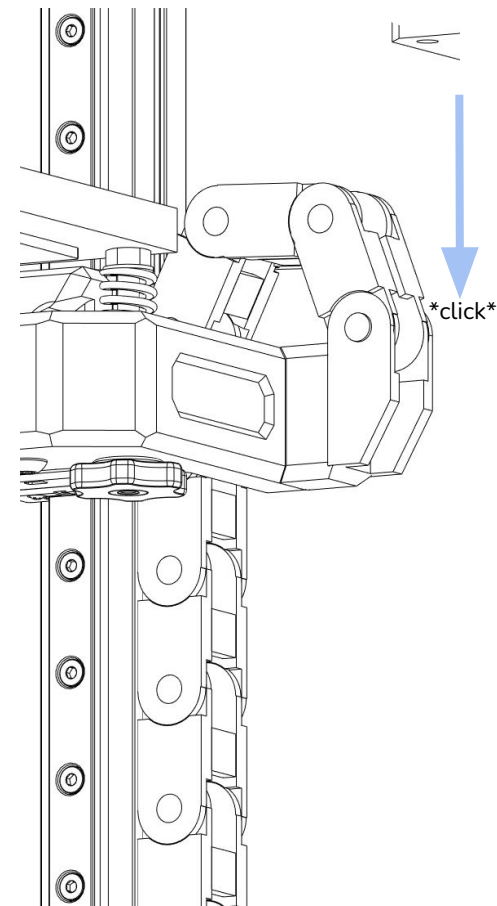

CABLE CHAIN

Guide the heater and thermistor wires through the cable chain.

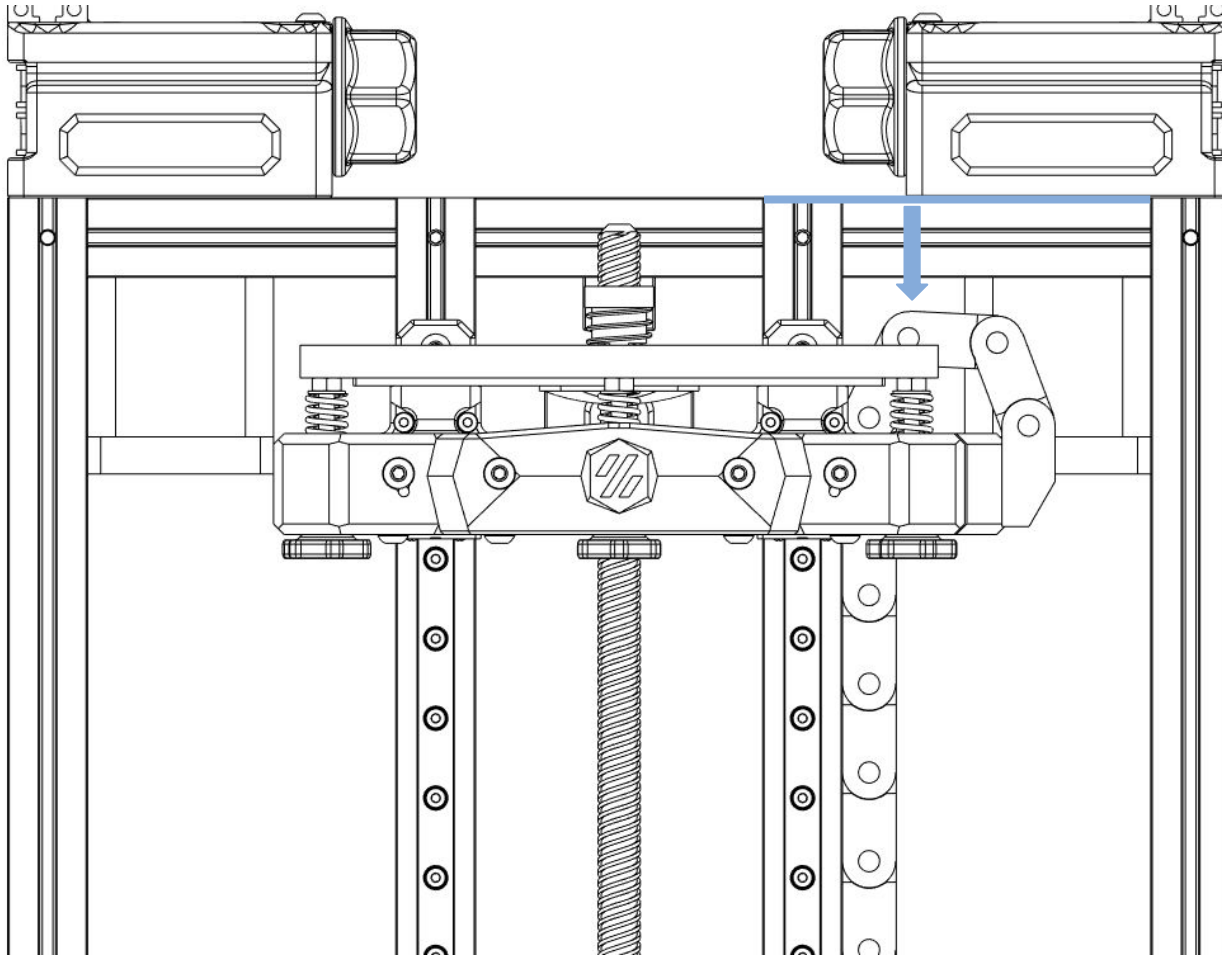

MIND THE GAP

The chain must not extend past the top of the Z extrusions when the bed is at its highest point.

We need to leave room for the gantry to pass over the top. The exact number of chain links needed depends on the size and type of chain you purchased.





Heat Set Insert

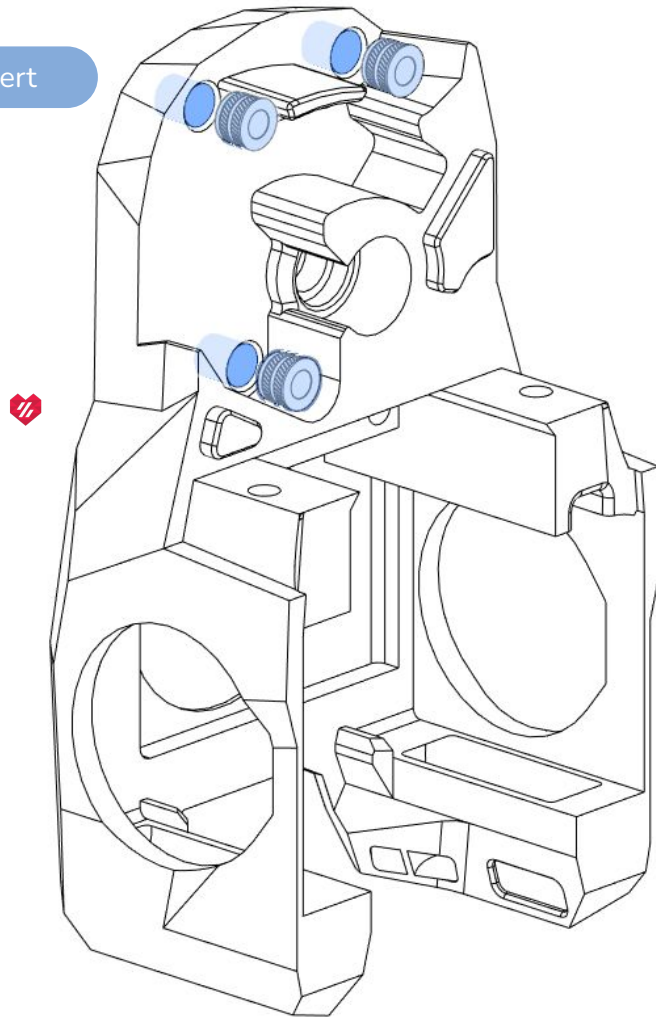

KNOW YOUR TARGET AND BEYOND

Before heating your iron, check that you will not contact, or unintentionally melt, surrounding plastic while installing heat inserts in the toolhead components.

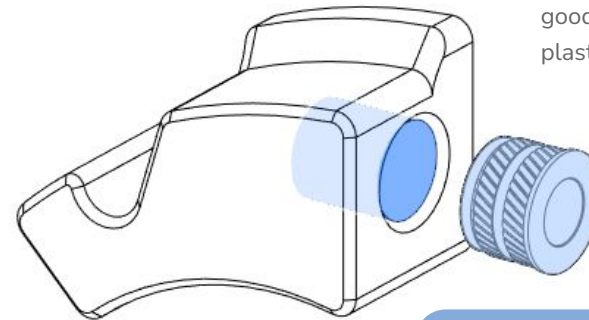

Heat Set Insert

GETTING A GOOD BOND

The heat set insert in the shuttle will be in constant tension when assembly is complete. It's important to get a good bond between the insert and the plastic for this part.

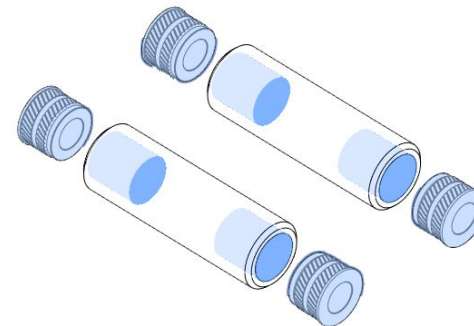

Heat Set Insert

STUPID !@#% STANDOFFS!

The printed standoffs are fiddly and weak...we know this. Luckily, if you want, you can buy solid metal M3x20mm standoffs that replace these printed parts.

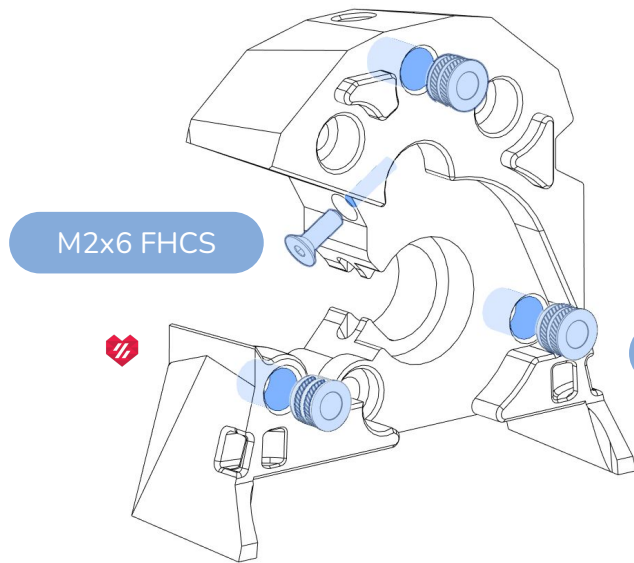

THREADING INTO PLASTIC

This M2 screw threads into the plastic of the Mid-Body part. It will be used to adjust the meshing of the BMG gears at a later step. Threading it all the way in at this step will make it easier to access later on.

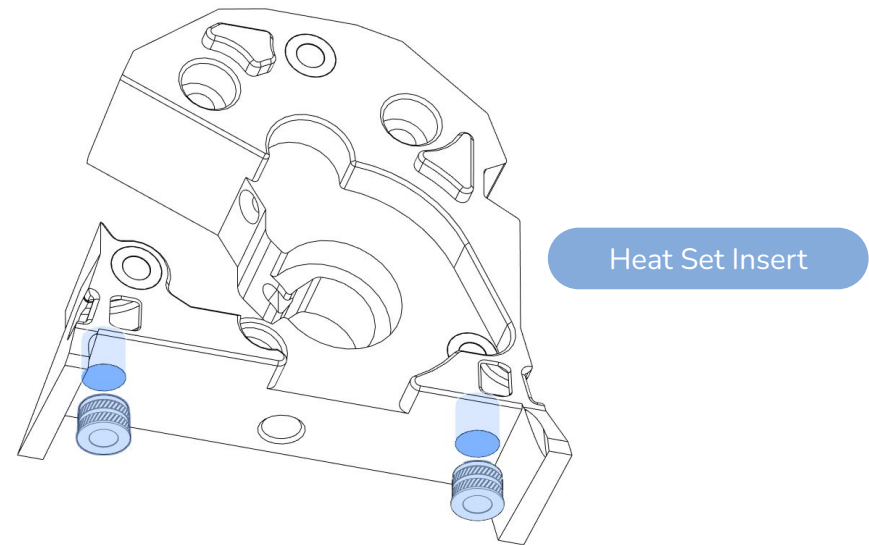

PRINT HEAD - COMPONENT PREP

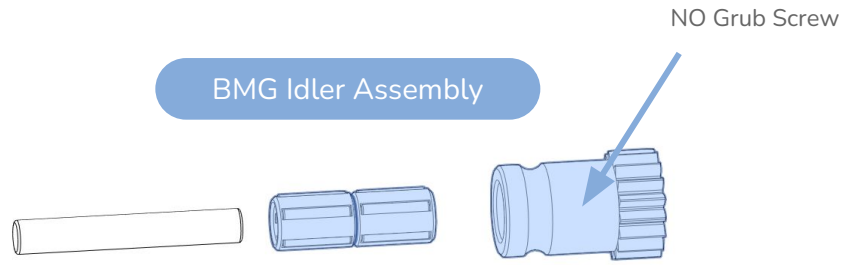

LUBRICATE BEARINGS

A lubrication film is required to ensure smooth operation and longevity. Refer to the [Voron sourcing guide](#) for lubricant options.

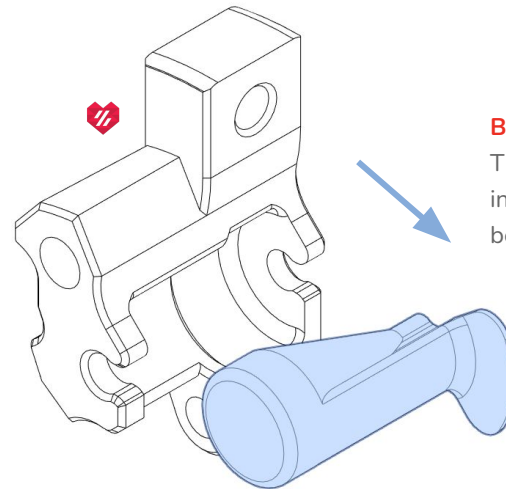

ADDED STRENGTH

This screw is there to provide extra strength to the guider component along its layer lines.

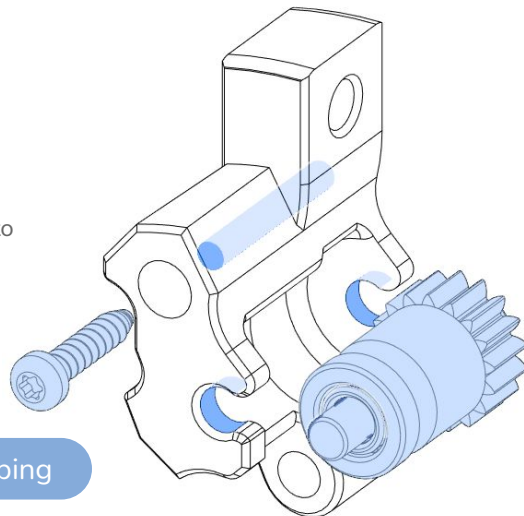

CHECK ORIENTATION

The larger gear section must be on the right hand side. Check for any rubbing or binding.

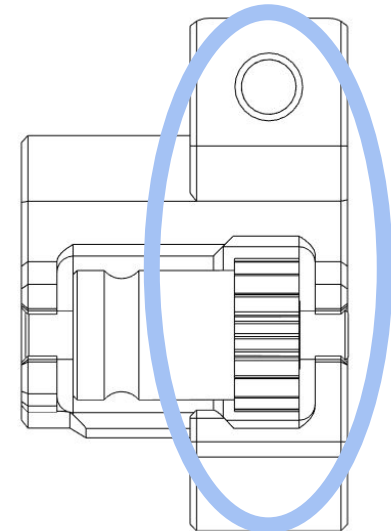

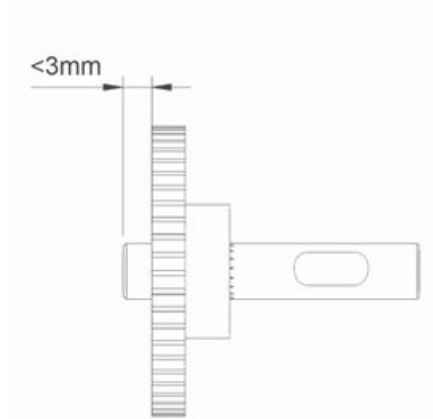

SHORT END OF THE SHAFT

Check the short end of the shaft. If it is longer than 3mm shorten it to under 3mm. The design for a printed jig that can be used to help sand down the shaft is included in the released files.

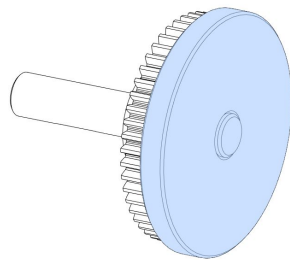

Printed Jig

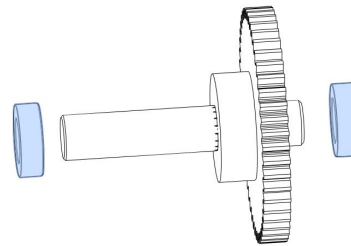

CHECK BEARING FIT

The bearings must slip on and off the shaft easily to allow the gear to self center. Do **not** shim into position.

Pressing the bearings on the shaft will damage them.

Lightly sand the shaft if required.

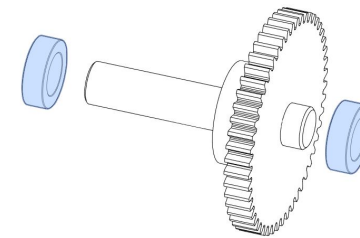
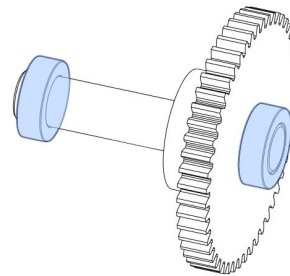

Remove the bearings from the shaft after checking the fit and continue with the assembly.

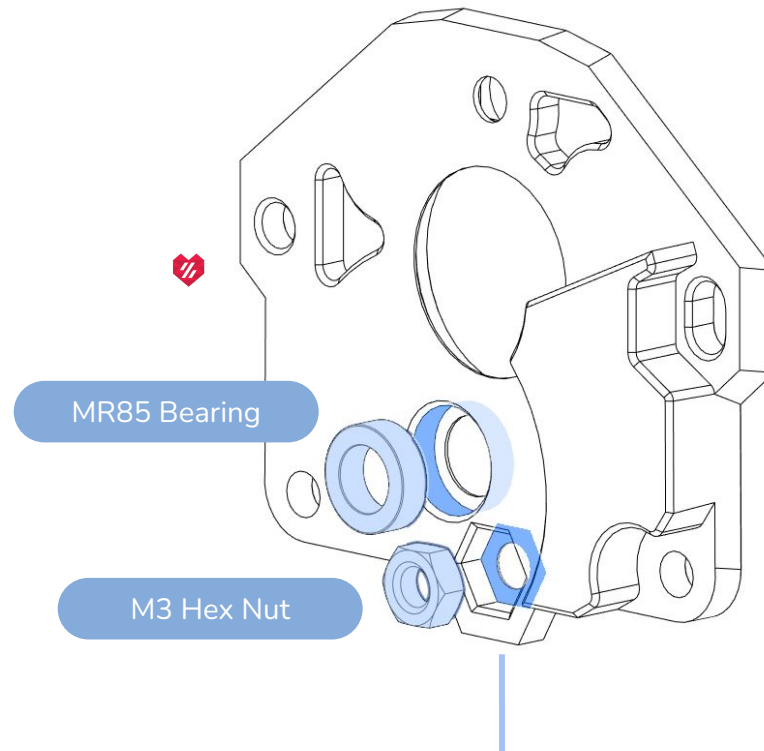

SUPER GLUE THIS HEX NUT

It is critical that this hex nut not come out of this printed part, adding a small dab of CA glue will help it stay in place, be sure not to get glue on the threads.

DO NOT apply glue to the bearing.

MR85 Bearing

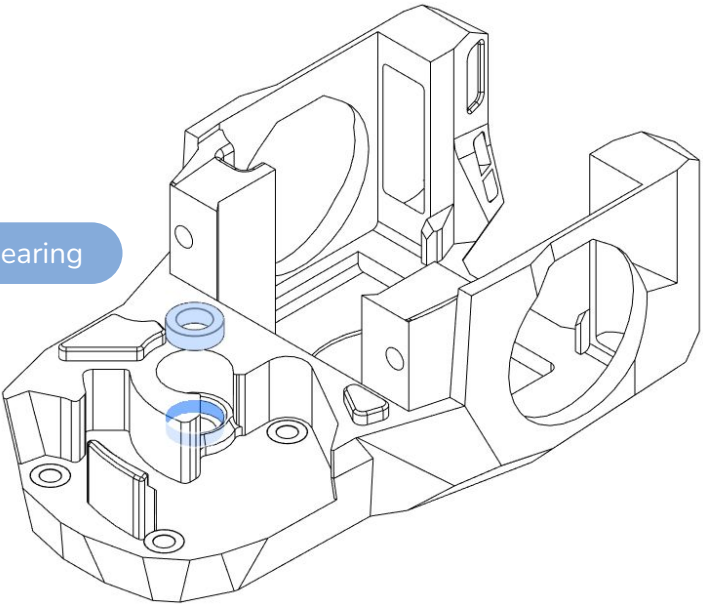

Shuttle

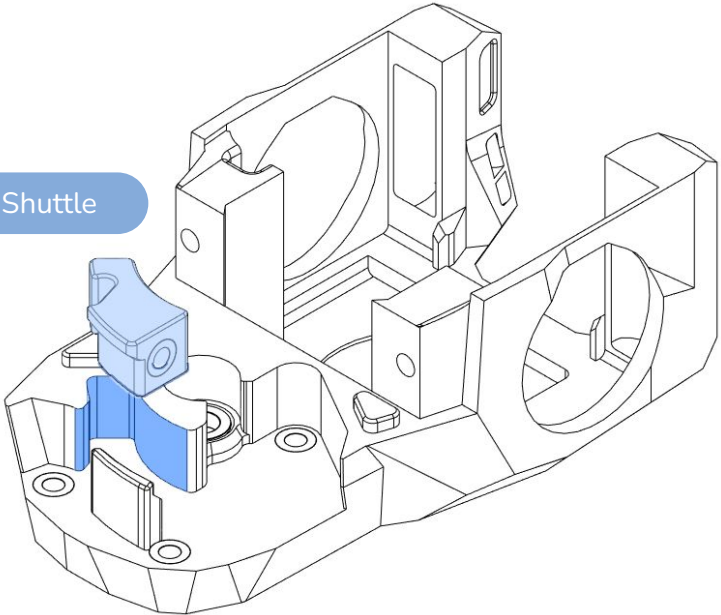

Guidler

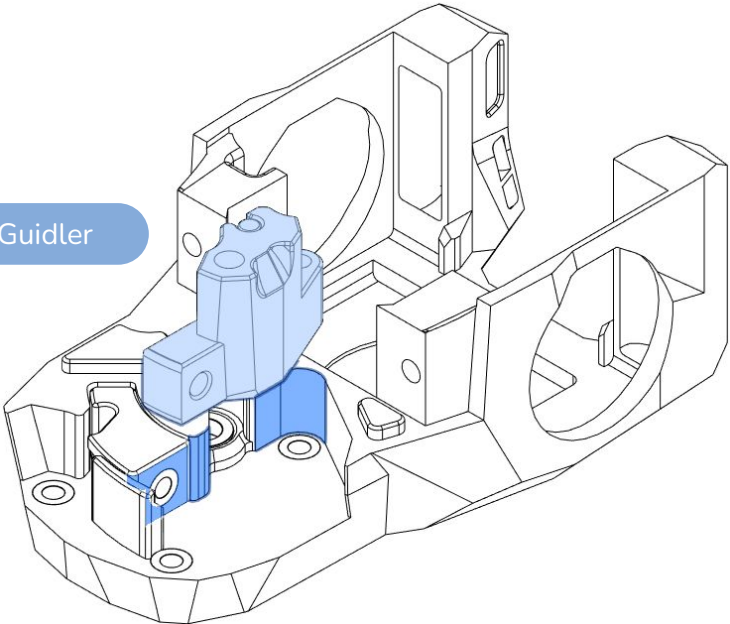

Latch

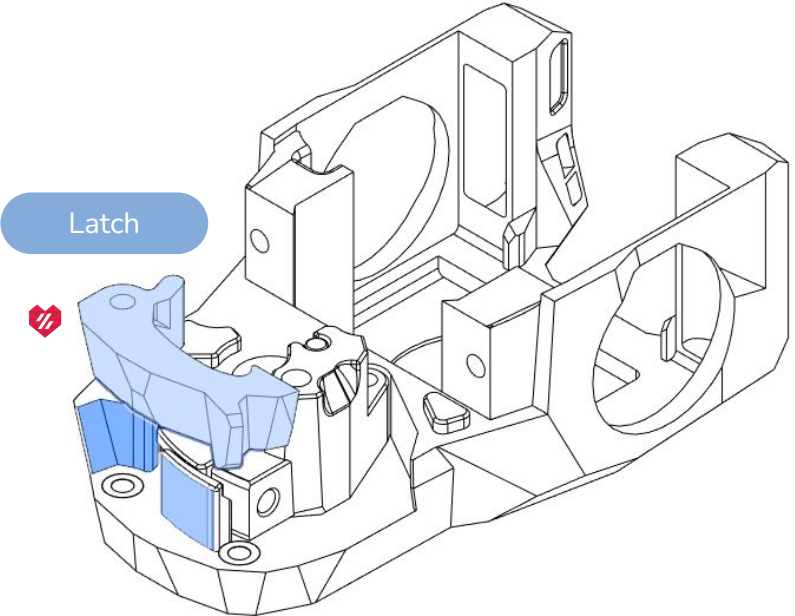

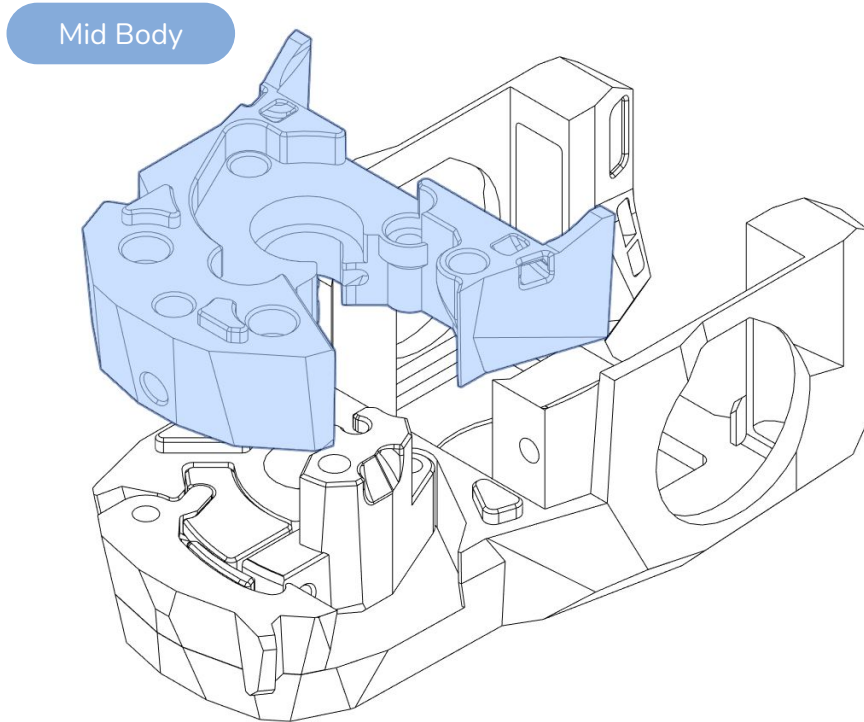

M3x25 BHCS

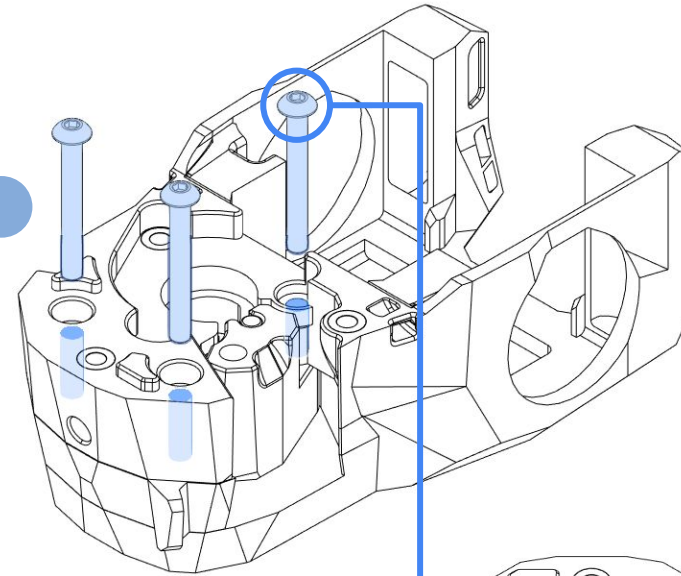

HINGE PIN

The lower M3x25 screw acts as a hinge pin for the guider arm, be sure not to over tighten it, check that the guider can still move smoothly.

M3x10 BHCS

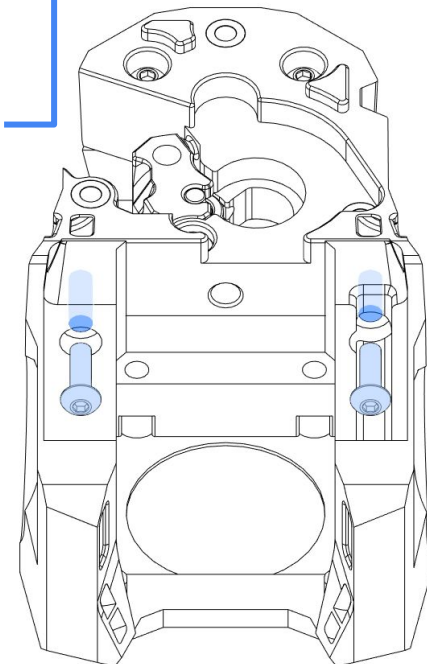

LOOSE GRUB SCREW!?

Be sure to loosen the grub screw enough that the gear can slide fully into position

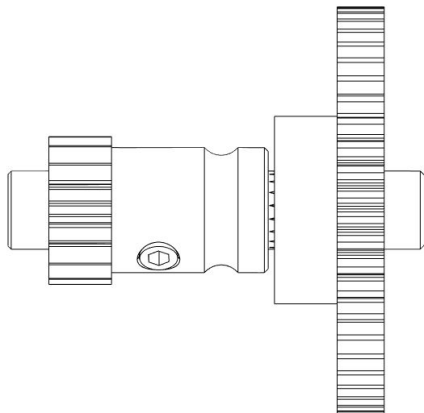
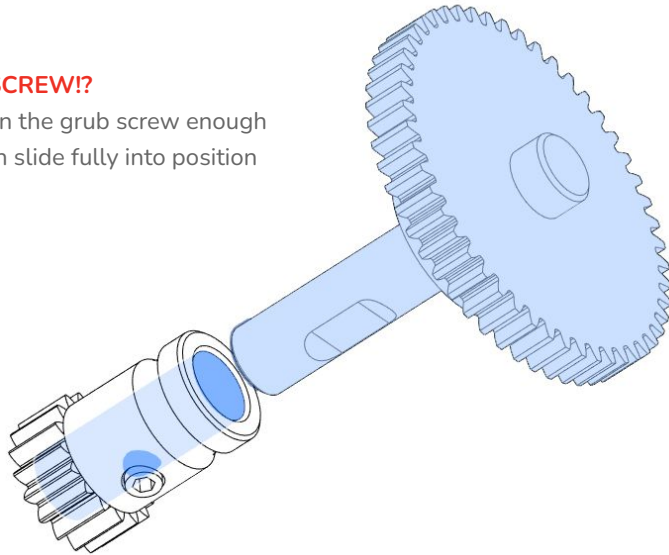

CHECK ORIENTATION

The drive gear is mounted opposite of how it is usually mounted in an extruder. Make sure that the grub screw has sufficient contact with the flat. Do not tighten the grub screw yet, we will finalize the gears exact position on the shaft in the next few steps.

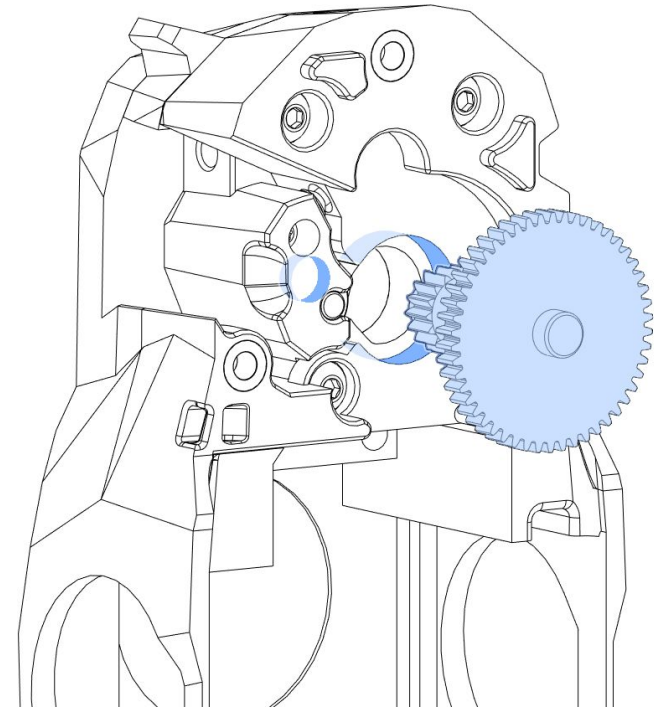

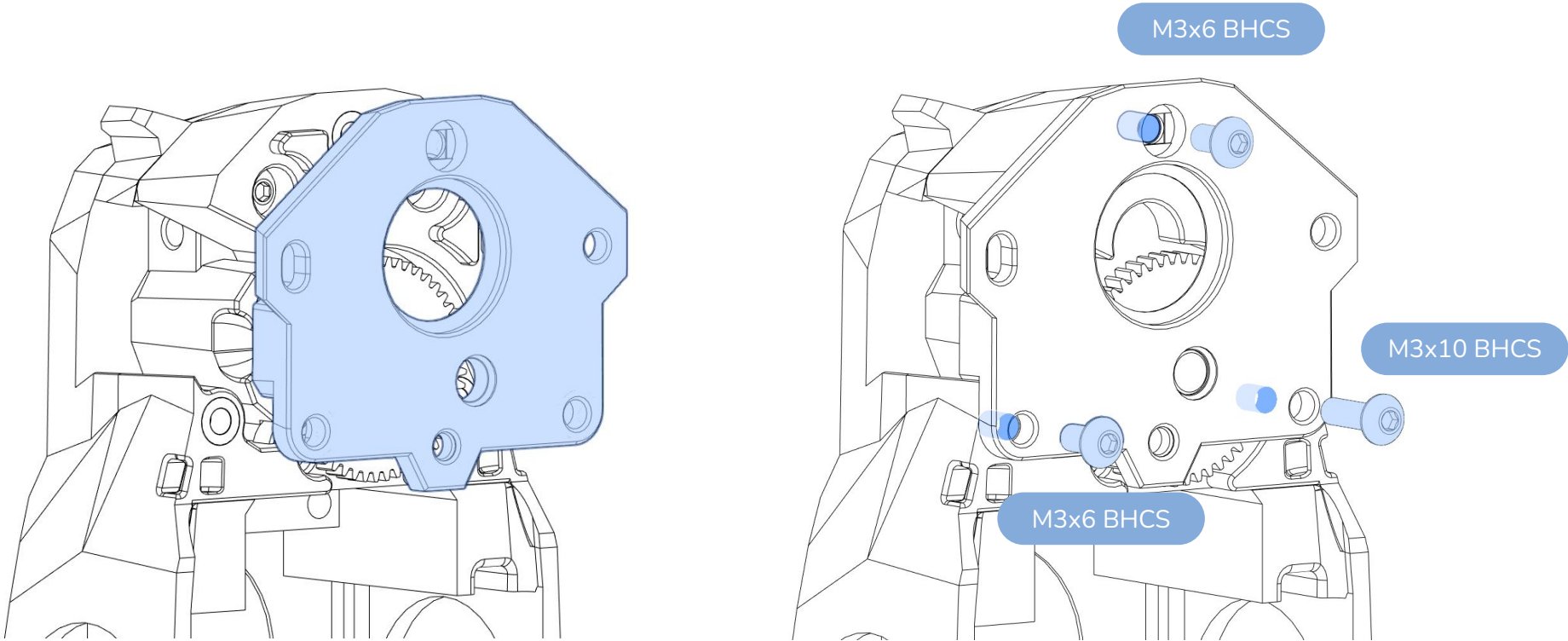

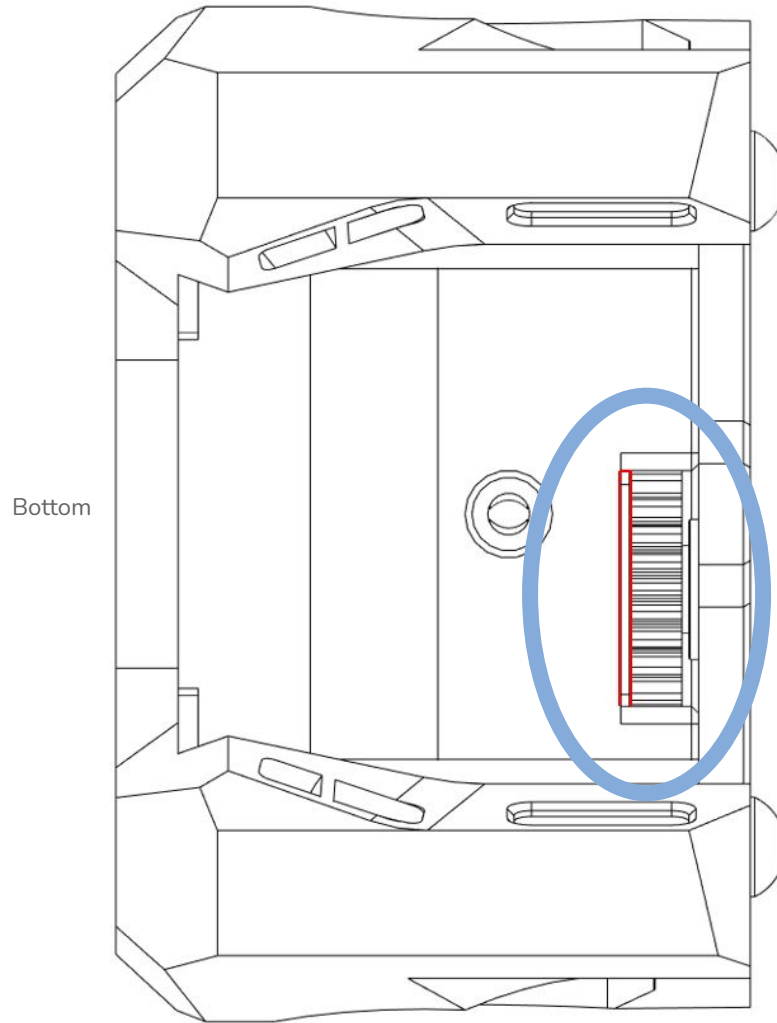

Bottom

50T GEAR SPACING

For the next steps we need to ensure that the 50T gear is not rubbing on any of the plastic parts. It should be generally centered in its available space between the mid-body and the motor plate, as shown below. Make sure your guider door is open so that you can freely adjust the position of the 50T.

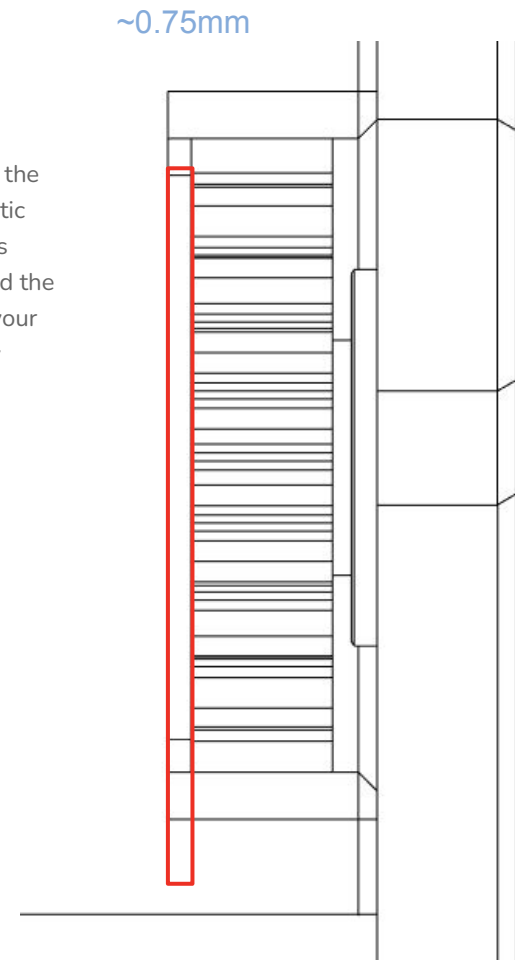

ALIGN THE DRIVE GEAR

While the 50T gear is centered open the guidler and loosen the grub screw on the BMG drive gear with a small allen key, then adjust its position left to right so that the filament path is aligned with the gear teeth. Hold the 50T in position while adjusting the drive gear so that it is still centered in its gap. Once happy, tighten the grub screw. Be sure to not rotate the 50T gear while doing this so that the flat section of the shaft is still under the grub screw location.

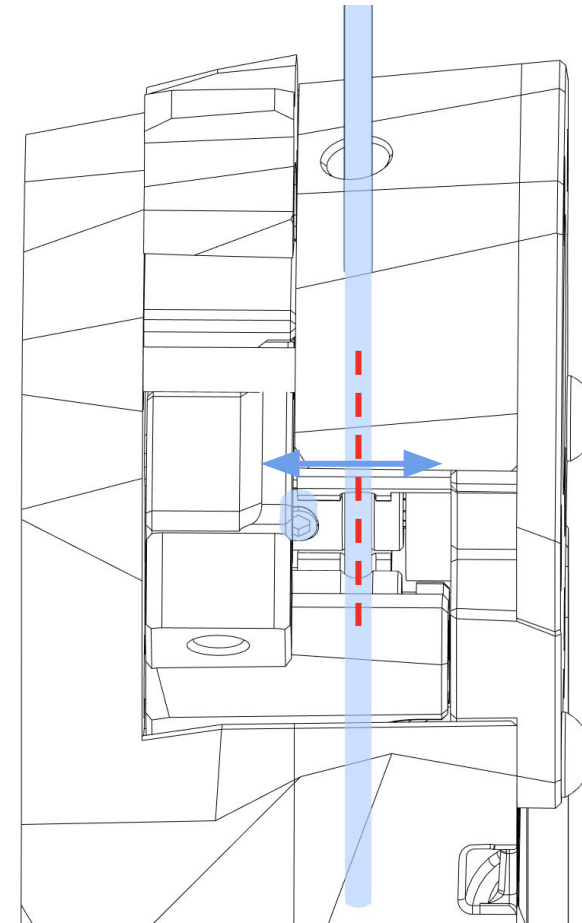
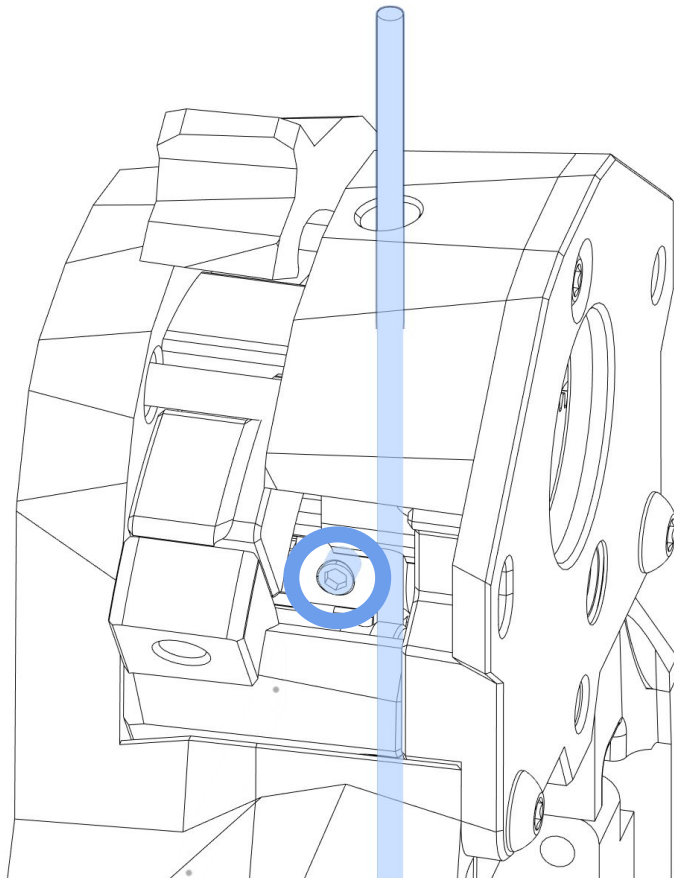

USE A PIECE OF FILAMENT

A piece of filament can be a handy guide to ensure the grooves in your drive gear align correctly with the filament path of the printed parts.

A NOTE ON SPRINGS

Longer/shorter/stiffer springs will change the tension characteristics and have an impact on how well the tension mechanism works. Consider buying the original Bondtech part as those are known to work well. If you sourced from a different vendor, check that it is roughly 12mm long with an outer diameter of 6mm and a wire thickness of 1mm.

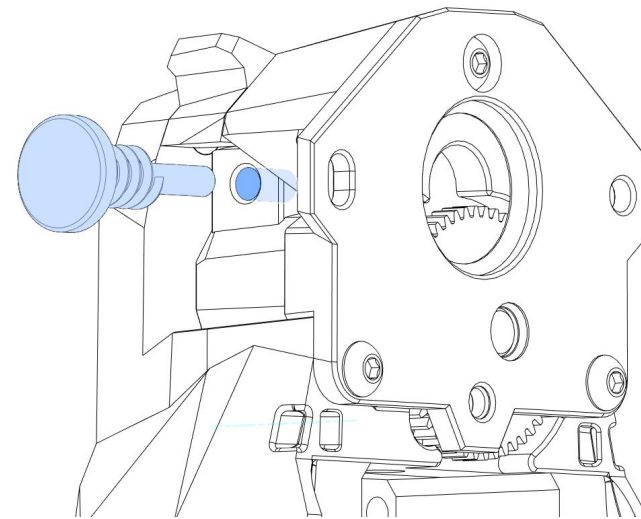
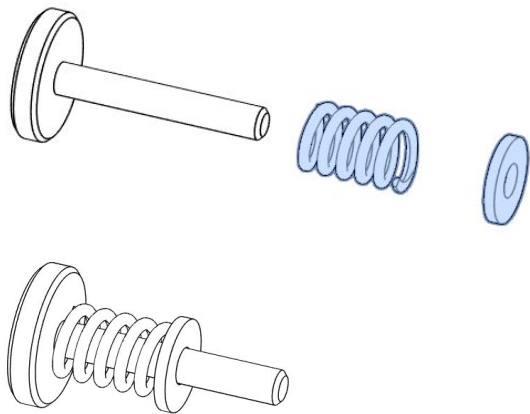

TENSION KNOB

Turning the thumb screw clockwise will increase the tension and grip on the filament. Too much tension will result in print issues.

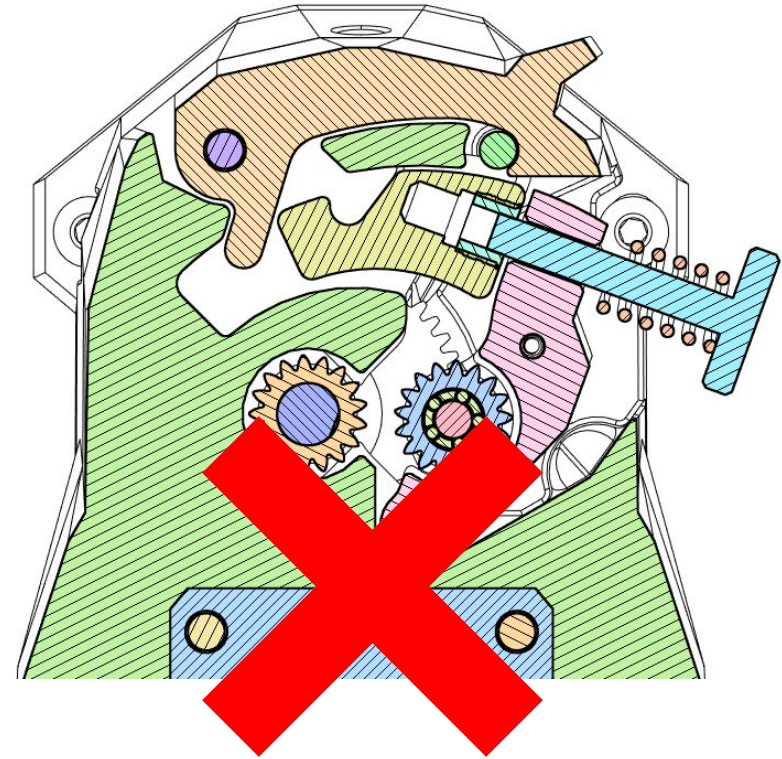
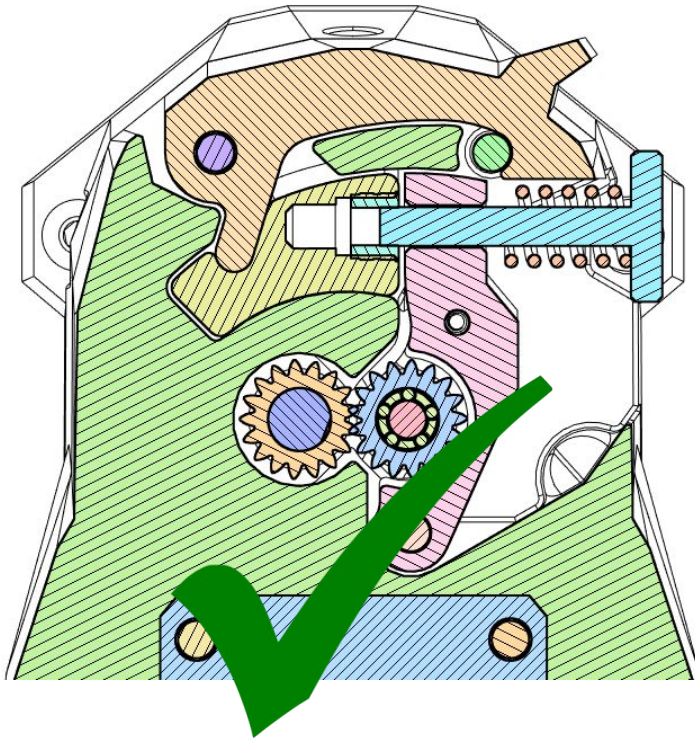

LATCH SHUTTLE

The latch mechanism must seat into the groove of the shuttle piece. This is what allows the extruder to grip the filament effectively.

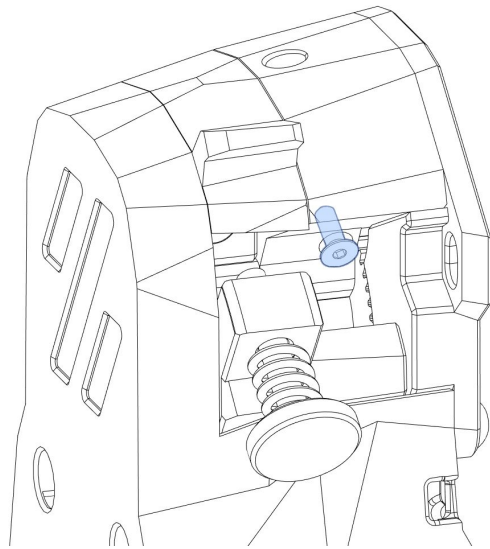

M2x6 FHCS

ANTI SQUISH THINGYMAJIG

Softer and flexible materials will deform and extrude poorly under too much tension. Mini Stealthburner adds an anti-squish thingymajig screw that sets the minimum distance between the drive gear and the idler, Backing this screw out increases this distance and tightening the screw in decreases this distance. Setting this minimum distance helps to prevent the gears from meshing too tightly or binding up in the extruder

LIGHT TEETH MARKS

Close the latch and put a piece of filament through the extruder, then spin the 50T with your finger to test the feeding capability. You are looking for light teeth marks on the surface of the filament. We will repeat this step once more after the motor is installed.

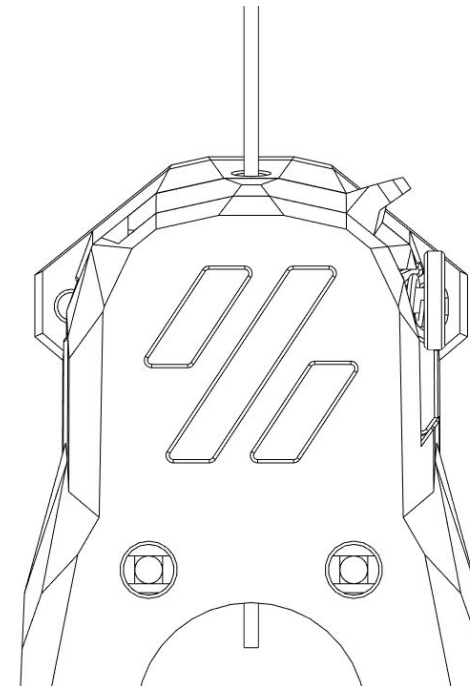

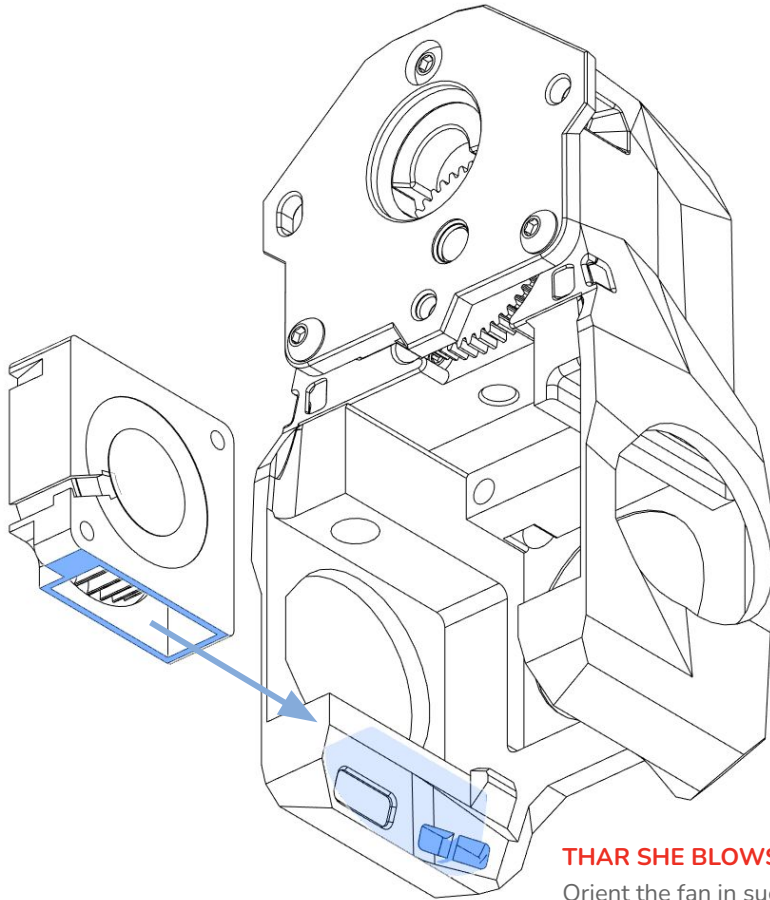

THAR SHE BLOWS

Orient the fan in such a way that the fan will blow down into the part cooling ducts.

Blower Fan

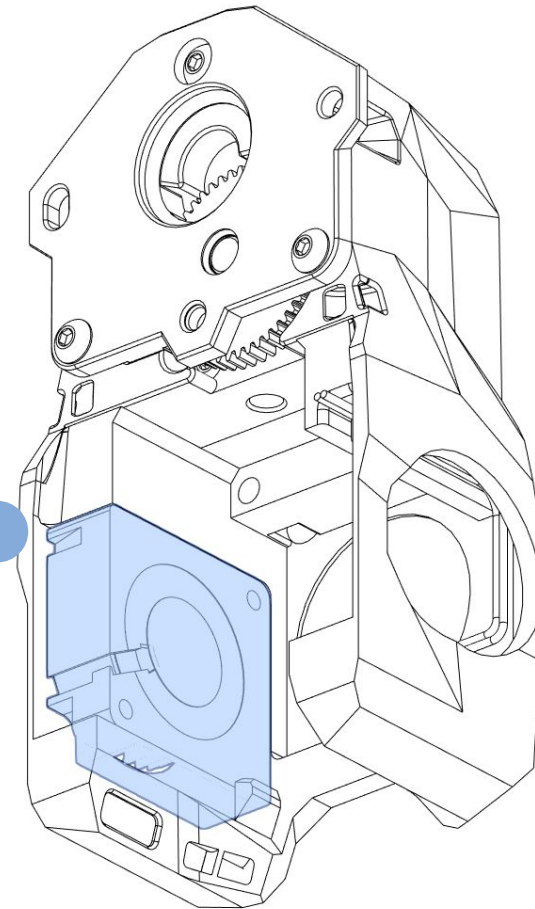

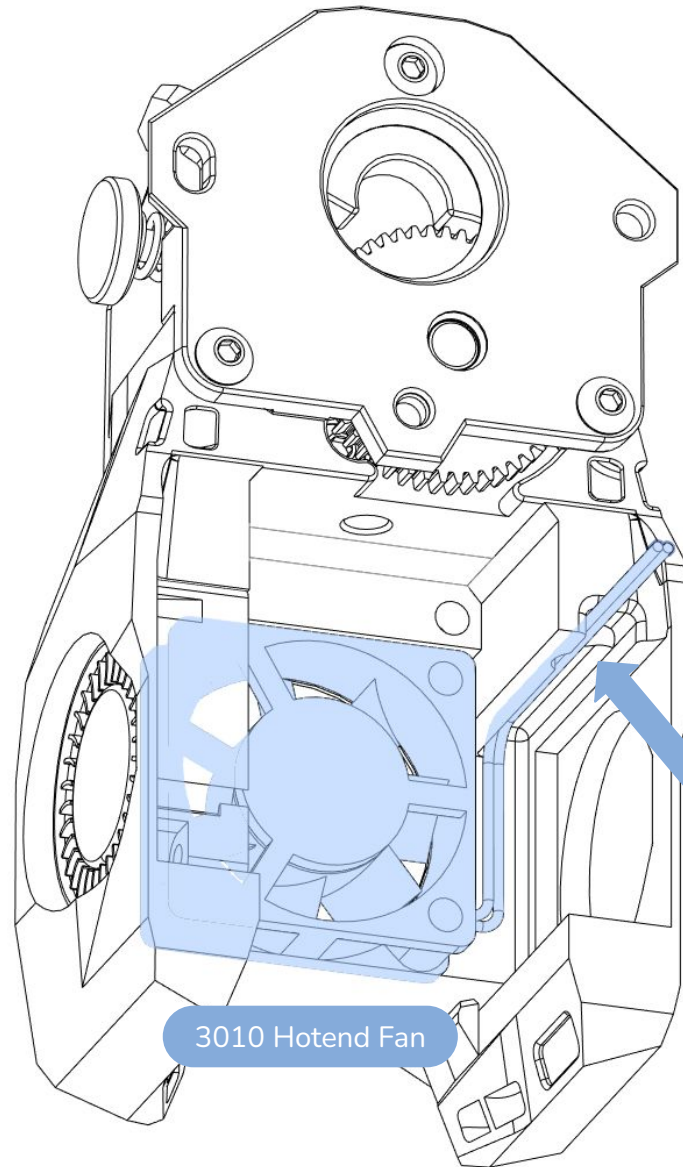

3010 Hotend Fan

AIRFLOW DIRECTION

Orient the fan in such a way that the air is pushed into the cowling. You'll find small arrows on the fan indicating the air flow direction. The side of the fan that has the sticker typically faces toward the hotend.

WIRING PATH

Orient the fan in such a way that you can guide the wires in the highlighted path.

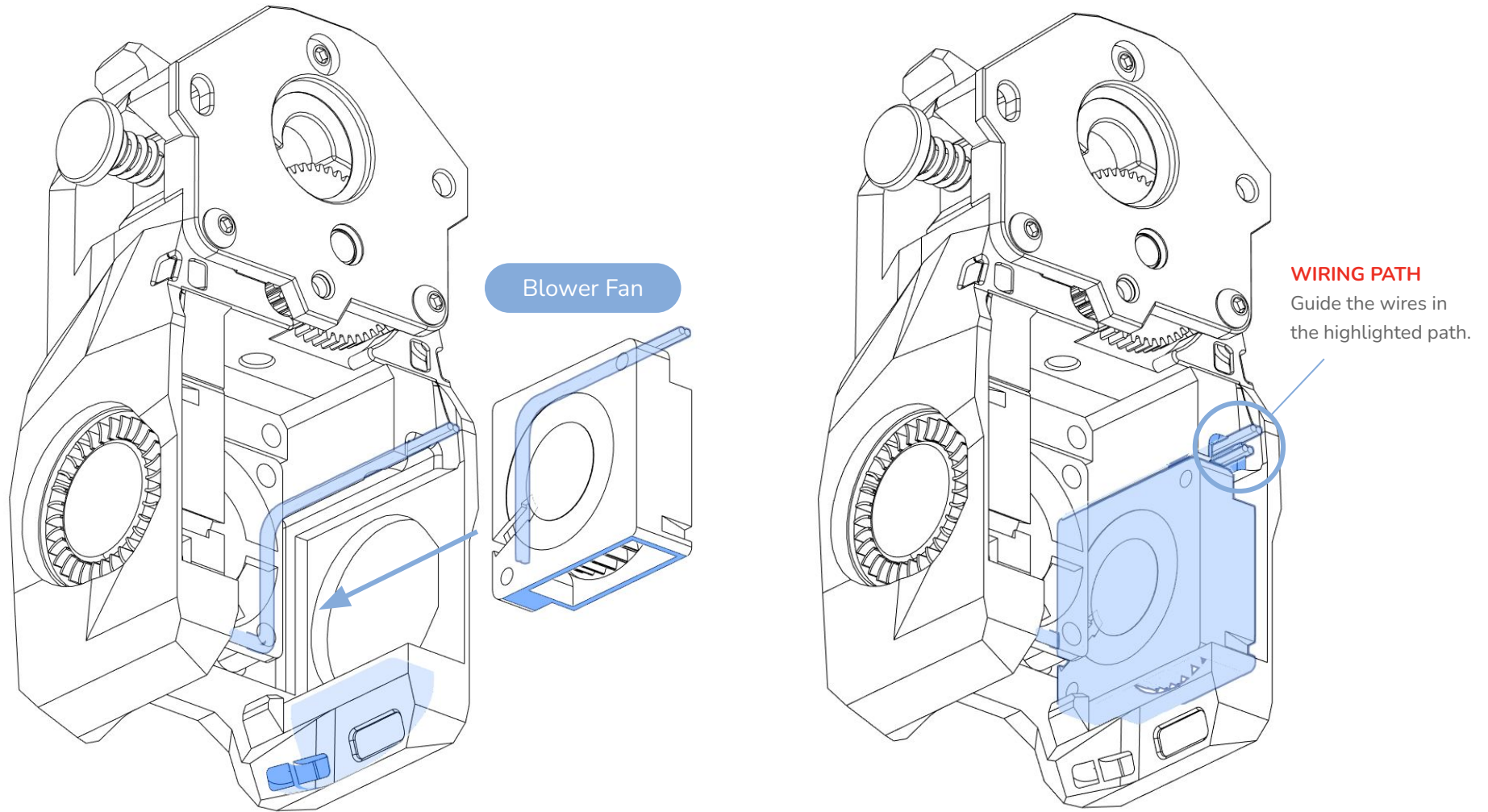

Pancake Stepper Motor

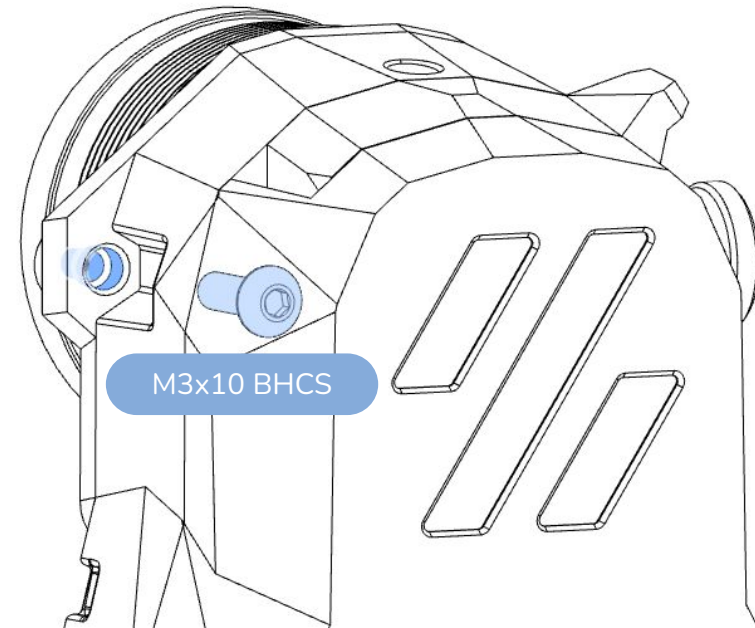
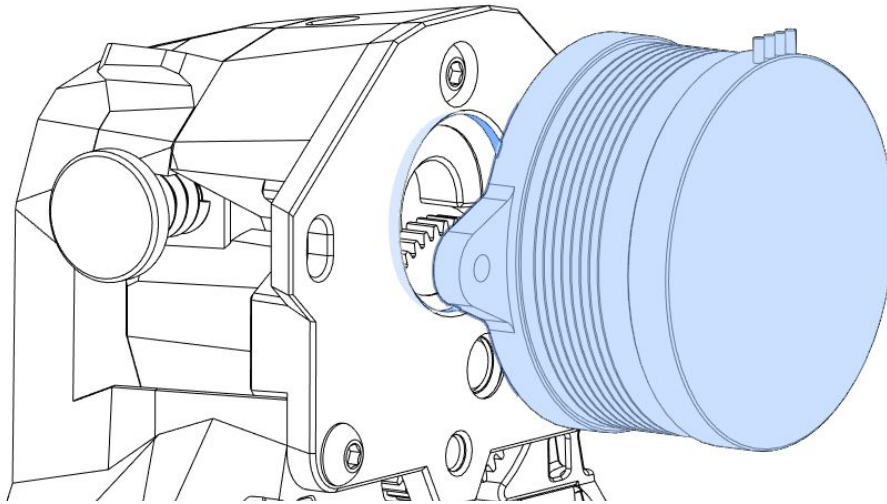

M3x10 BHCS

GETTING GEARED UP

We are only slightly tightening this M3x10 for now. We will be setting the proper gear mesh before fully tightening the motor to the rear of the print head.

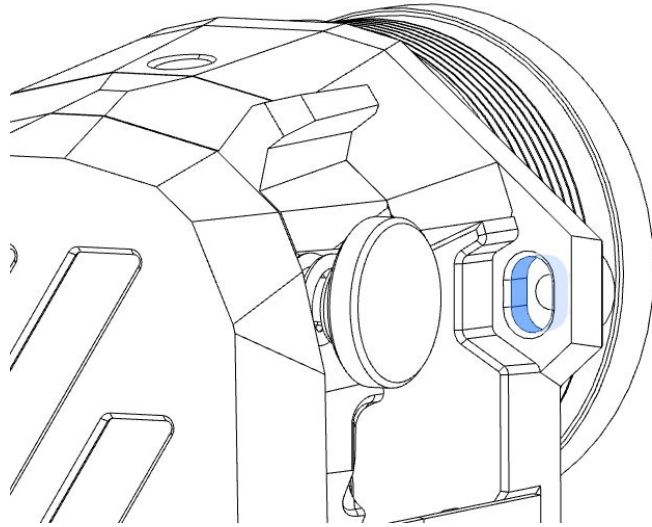

DESIGN WITH INTENT

The screw hole on the right of the motor plate is slotted to allow proper gear mesh adjustment. This is also called “backlash.”

The M3x10 BHCS we are inserting here will need to be **loose** until proper backlash is found.

M3x10mm...ARE YOU SURE?

Yes, these screws need to have extra thread on the back side to attach spacers for the strain relief. If you are using a toolhead PCB you still need the extra thread and spacers.

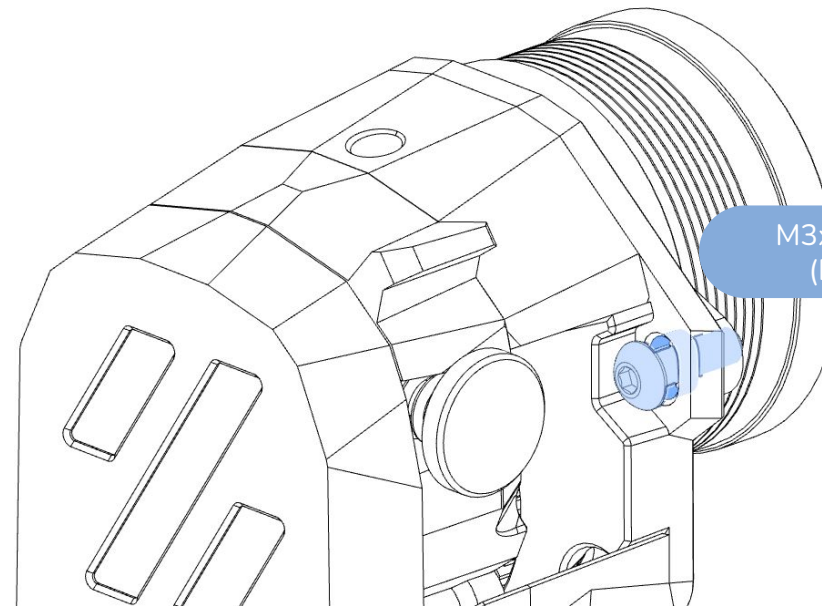

M3x10 BHCS
(LOOSE)

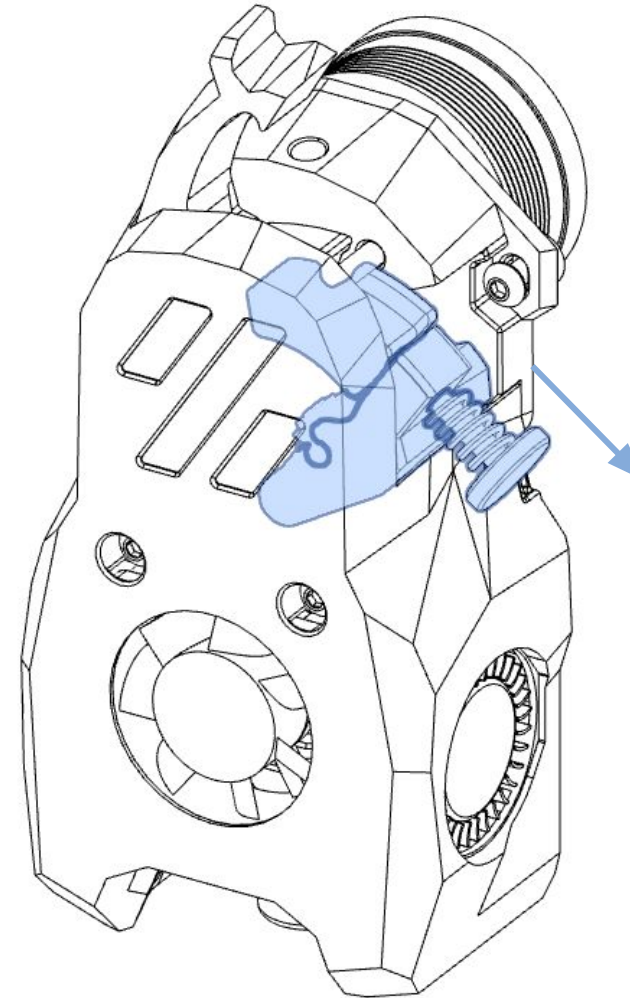
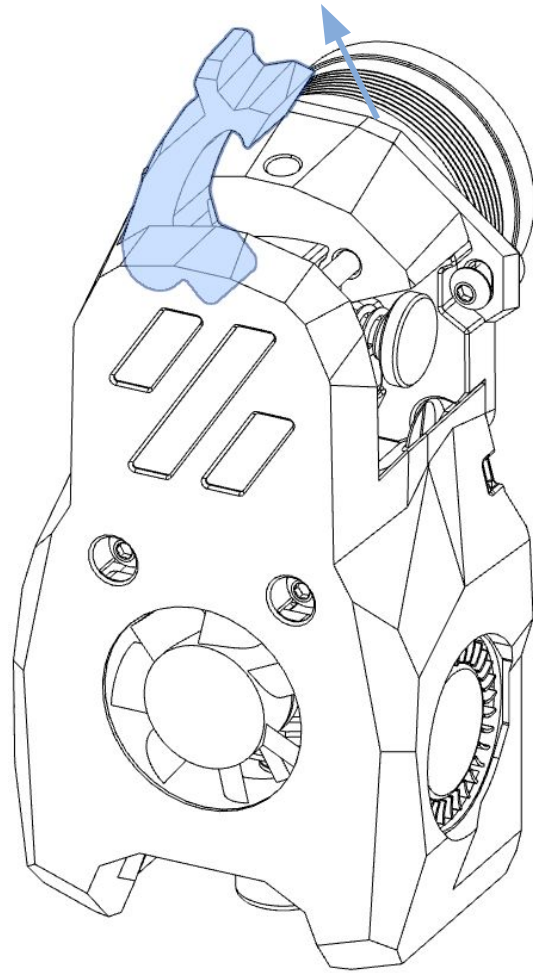

BETTER GET YOUR BI-FOCALS

Open up the extruder latch and drop the guider down so you can freely rotate the 50T gear.

On the next page we will be setting the proper gear mesh between the motor 10T pinion and the BMG 50T gear. You will benefit from good lighting and some magnification, but it is not a requirement.



ADJUSTING MOTOR BACKLASH

We need to adjust the amount of engagement between the motor pinion and the 50T gear.

With the latch and guidler open, hold the print head at an angle that allows you to easily see and move the 50T gear.

Use your finger to manipulate the 50T gear back and forth. As you do so rotate the motor down into the gear. As the two gears begin to mesh you will feel and see the play in the 50T gear become less and less. Once you have a very small amount of movement, your gear meshing is set.

Once you feel good about the gear meshing you have, snug up the two M3x10 BHCS in the next step, and make sure you still have some backlash after you have those screws tightened. Zero backlash will cause premature wear of the 50T gear.

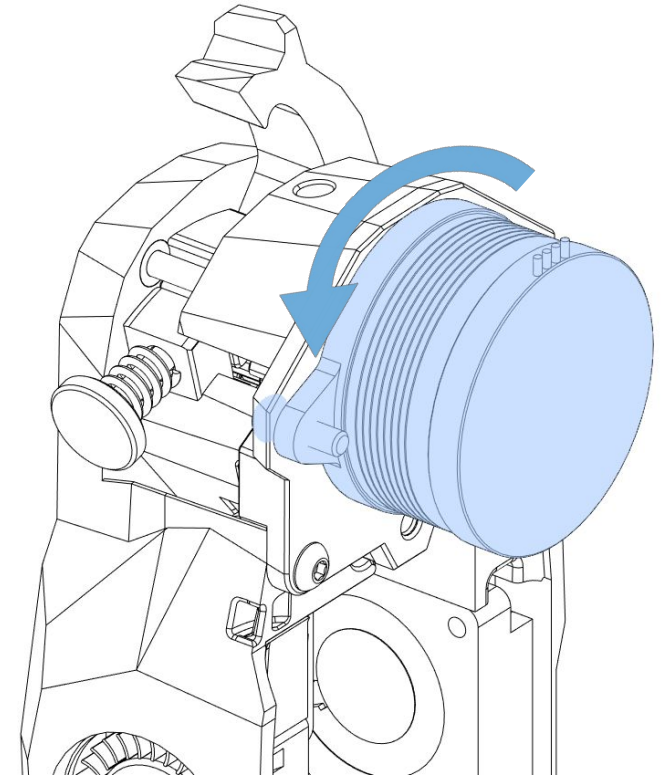
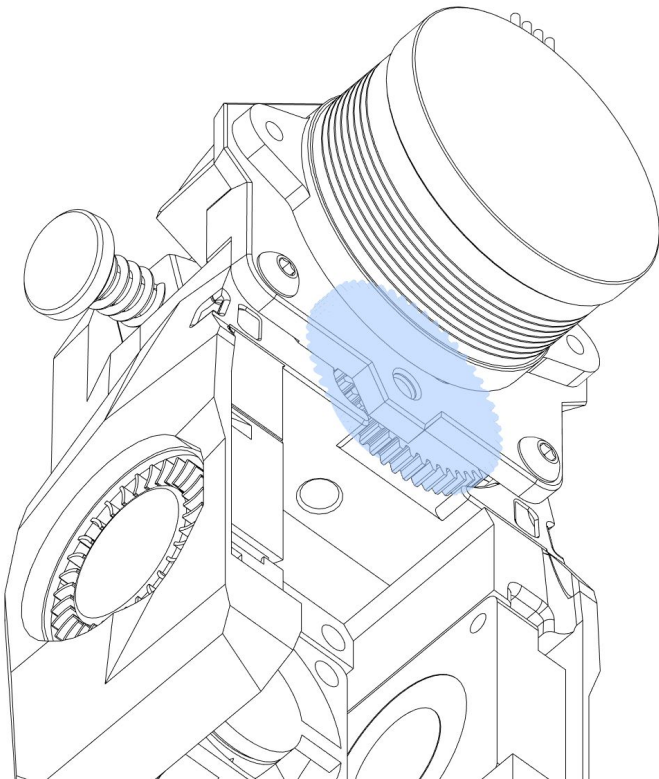

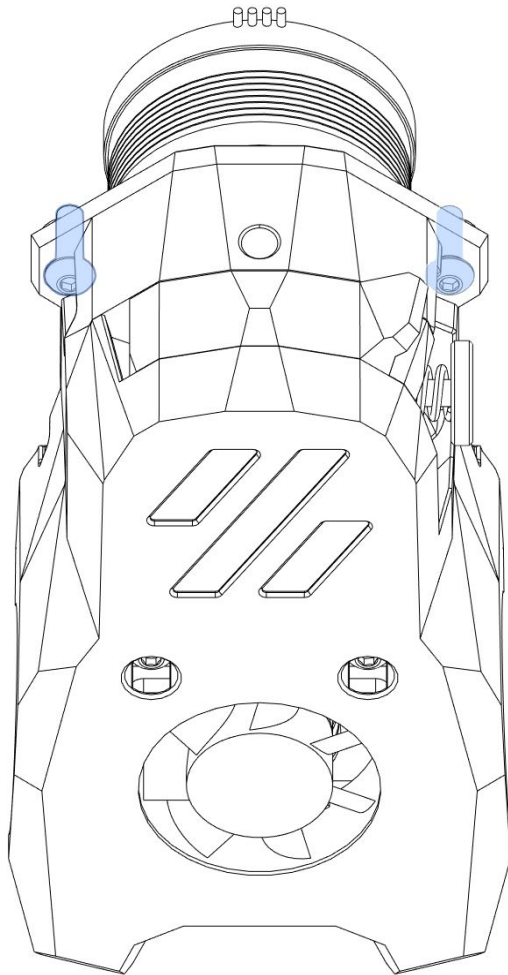

M3x10 BHCS

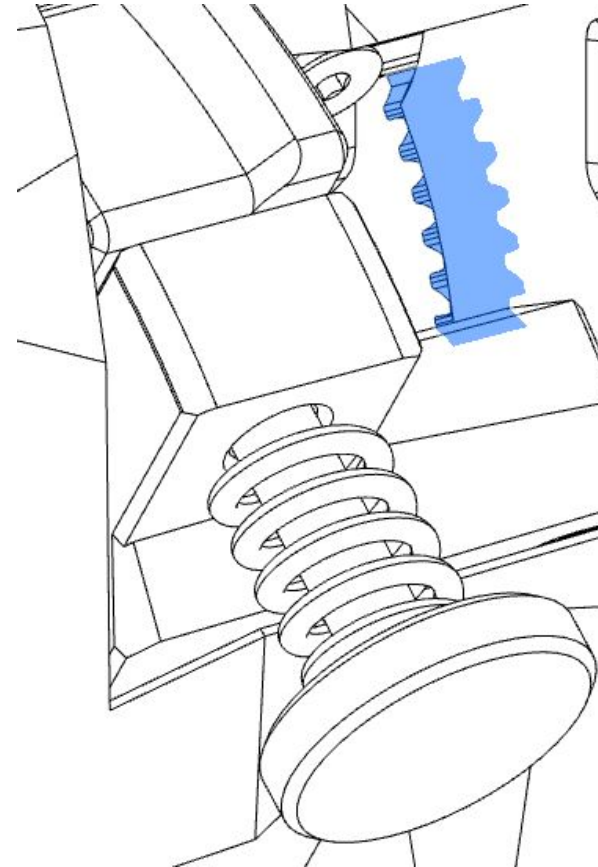

BETTER SAFE THAN SORRY

After tightening down these 2 screws, be sure to re-check that you still have proper gear meshing and that you still get light teeth marks on the filament when it is fed through the extruder so there are no surprises when the time comes to push plastic.

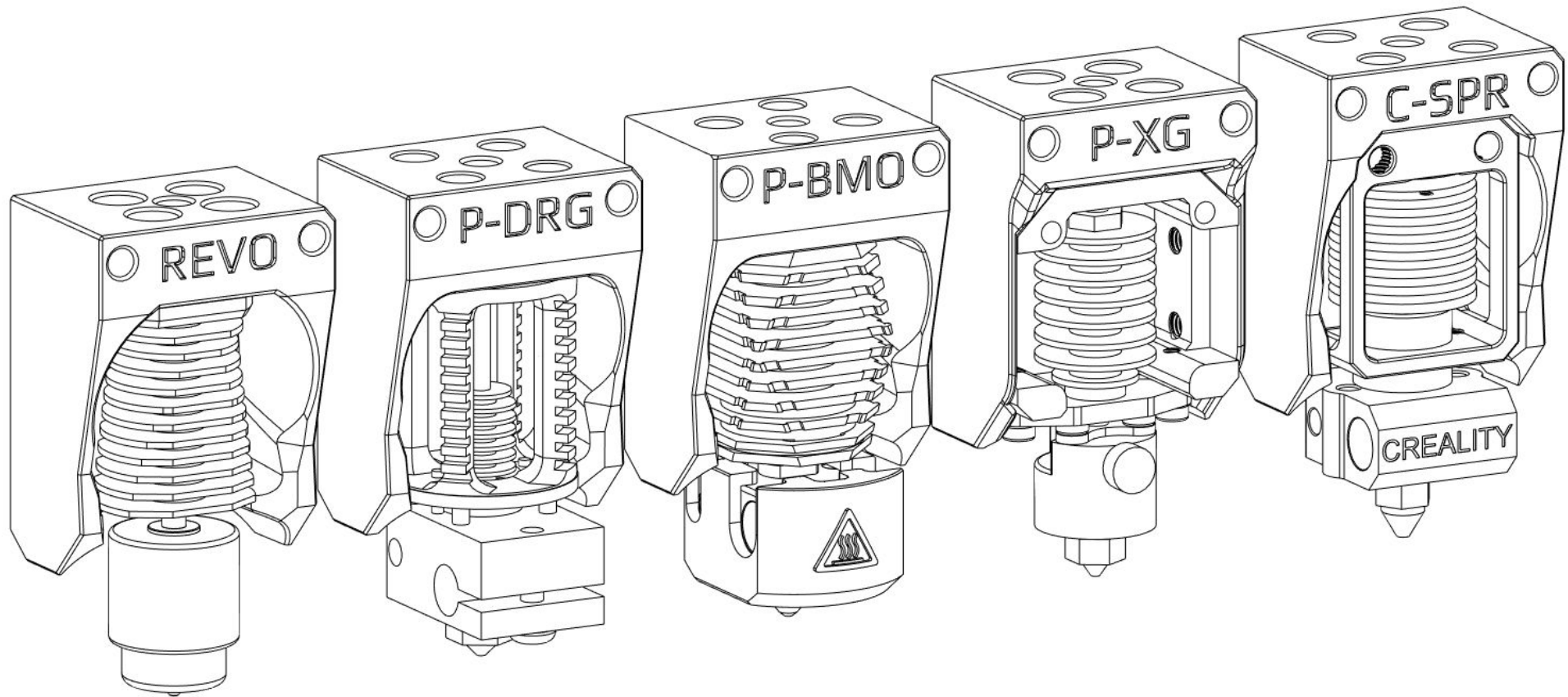

HOBSON'S CHOICE...

There are a number of hotends that are compatible with the V0 toolhead. There is no “best” hotend, choose the hotend that fits the criteria you find most important. The rest of the toolhead instructions will show only the Revo Voron. The only difference in assembly between the hotends will be the screws needed on the next page.

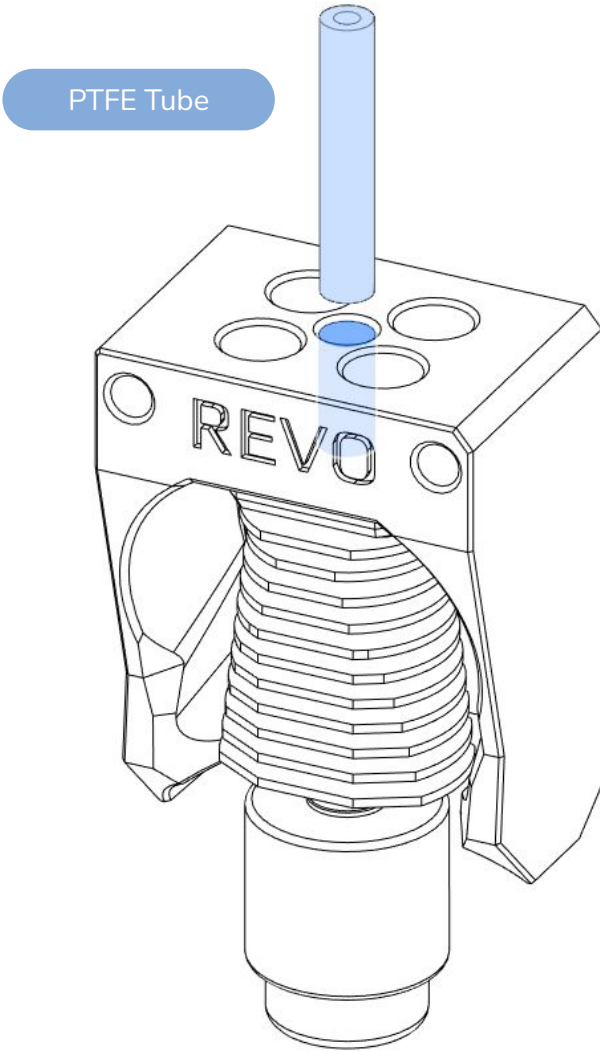
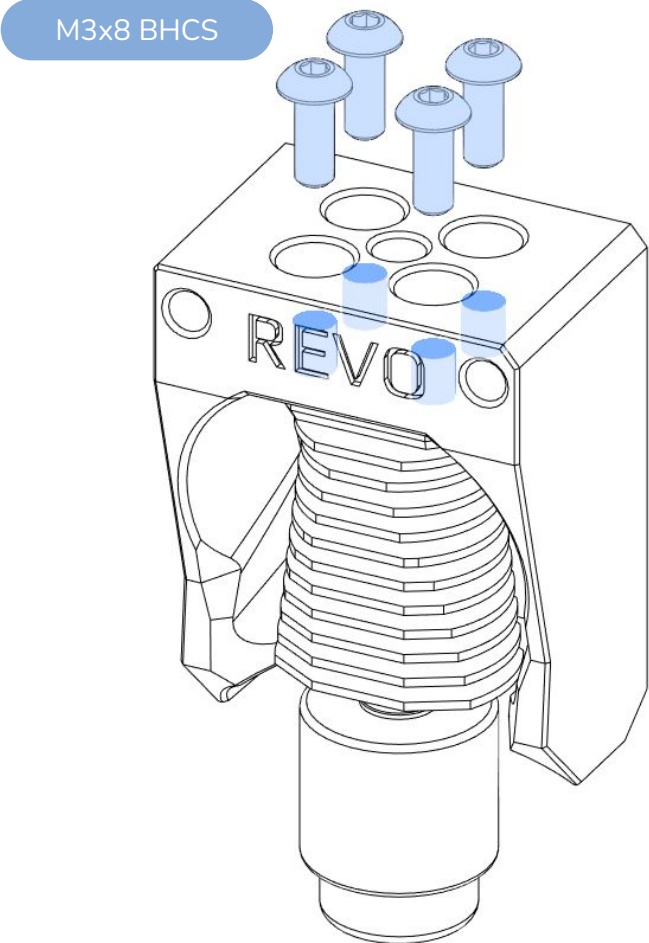
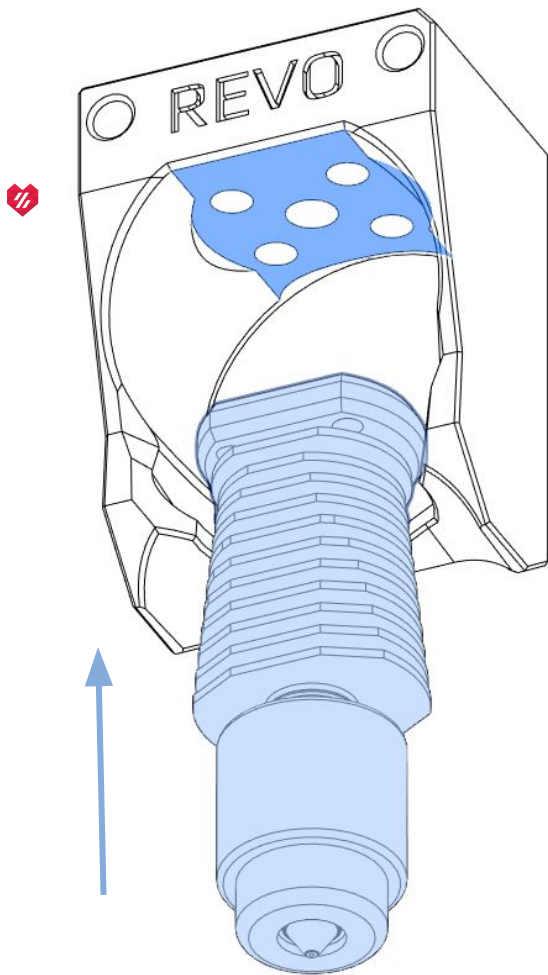

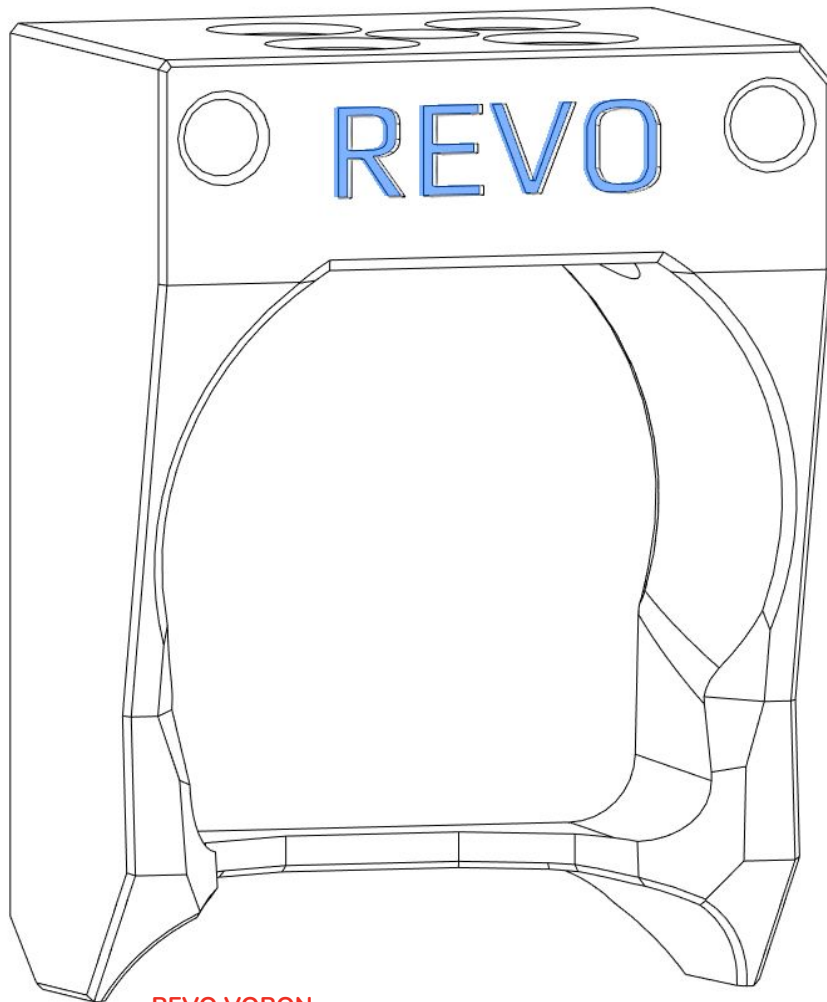

REVO VORON

The hardware and assembly shown here is for the REVO Voron hotend. Your hotend may use different screw lengths, each hotend also has a printed mount that is specific to the hotend being used.

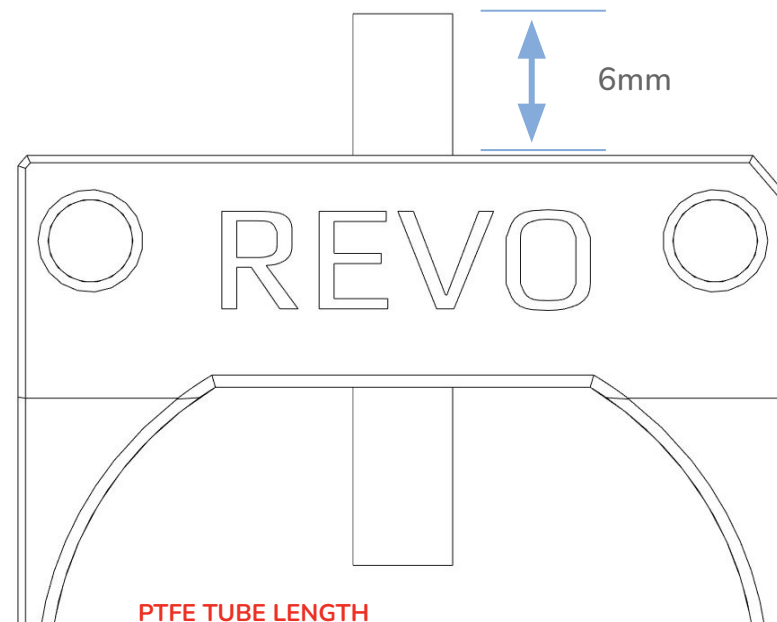

PTFE TUBE LENGTH

The total length of your PTFE tube will be dependant on the hotend you choose. Regardless, the tube must be cut to a length which enables it to protrude from the top of the hotend mount by 6mm. The other end of the tube should be captured by the hotend. When installed in the rest of the toolhead, the tube should not have any extra room to move up or down.

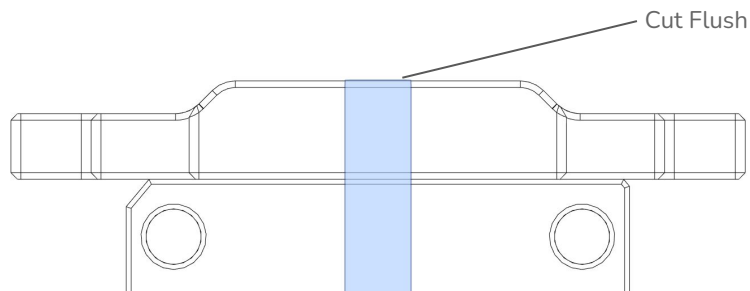
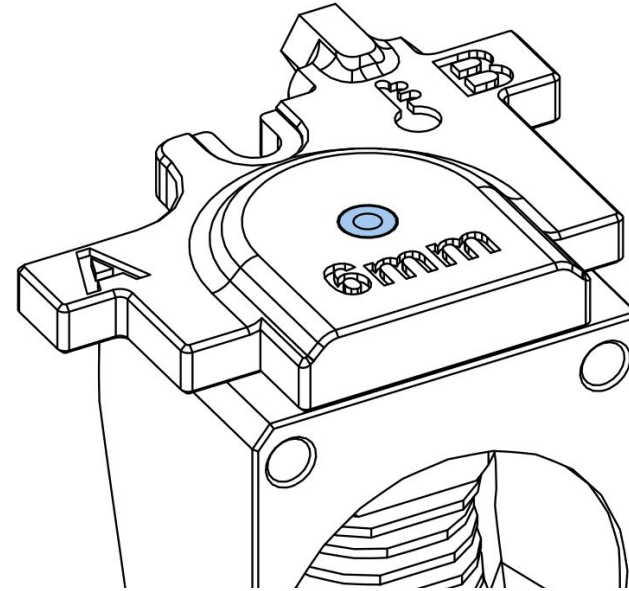
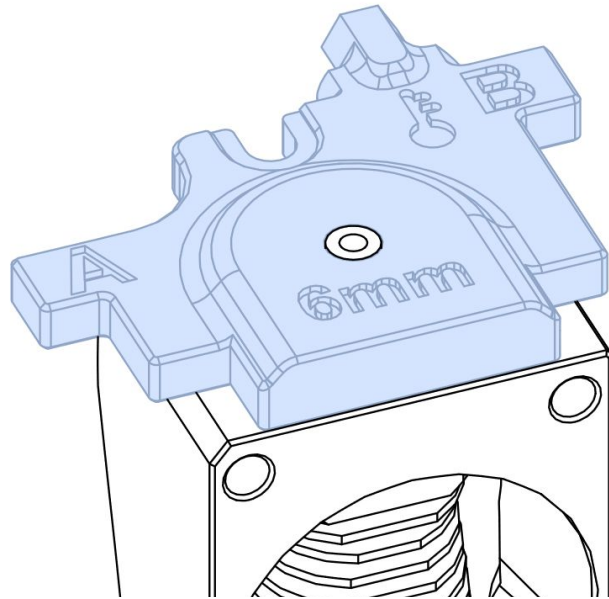

SWISS ARMY JIG

The pulley jig can also be used to trim the top of the PTFE tube to the correct length. Trim the PTFE tube after you have mounted the hotend to the plastic hotend mount and after you have inserted the PTFE tube as far into the heatsink as it will go.

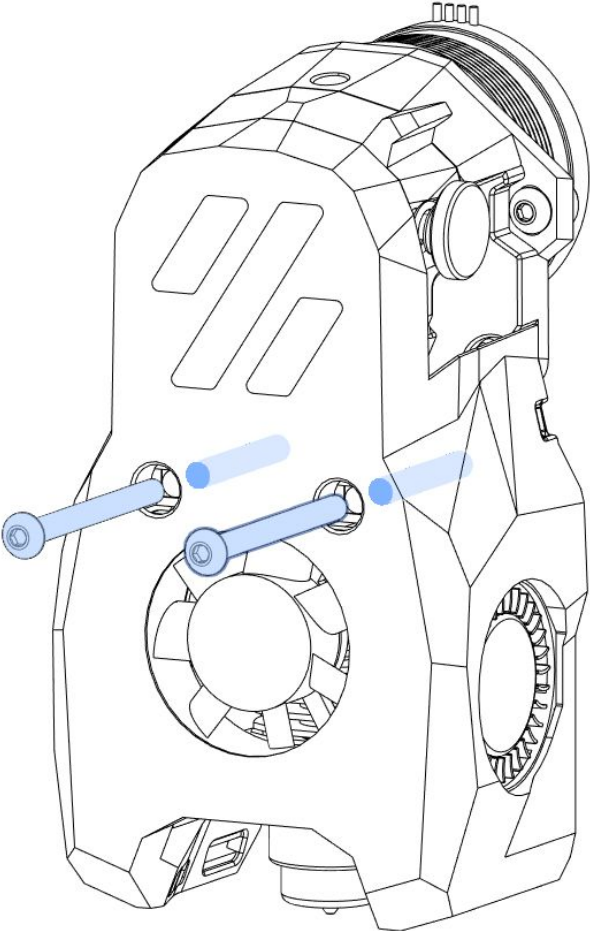
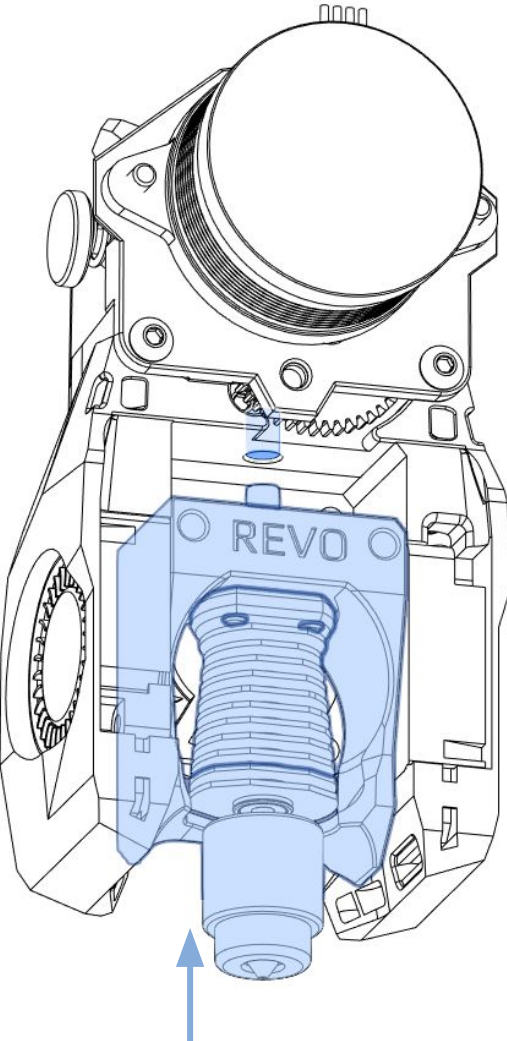

M3x35 BHCS

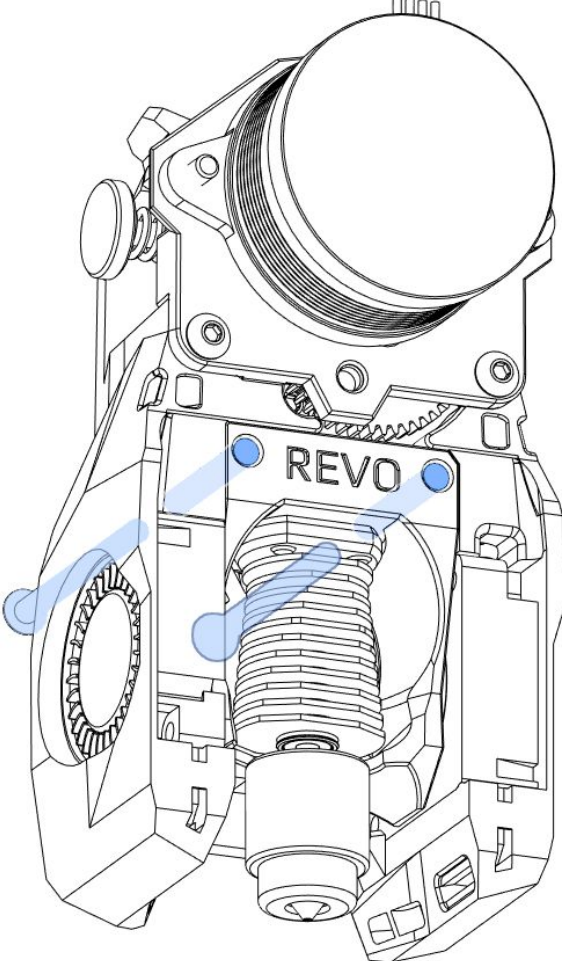

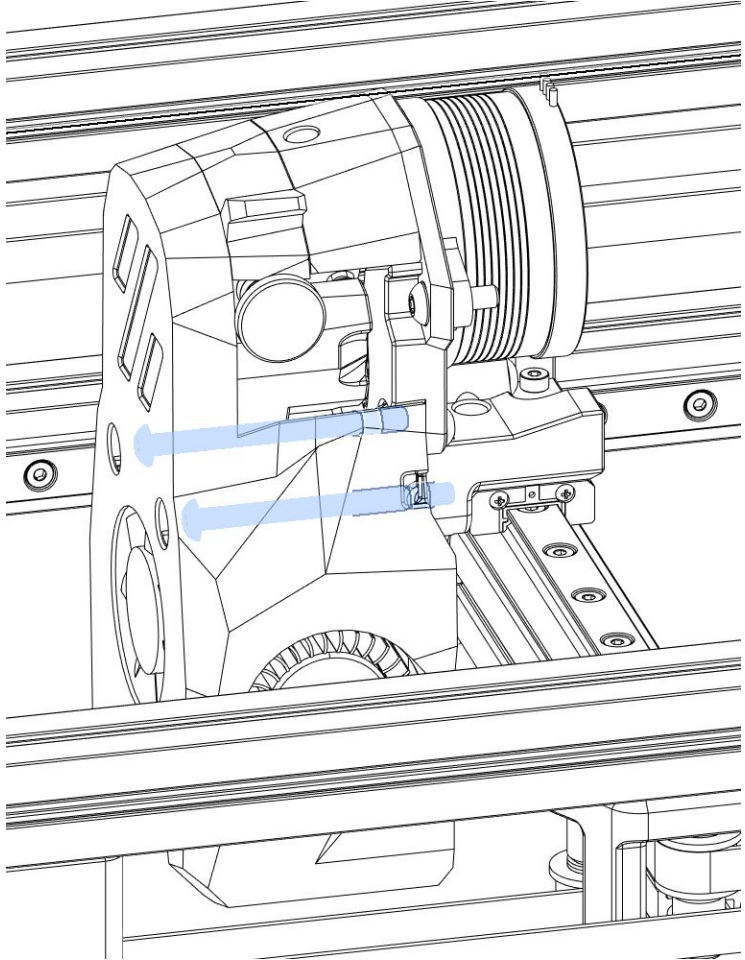
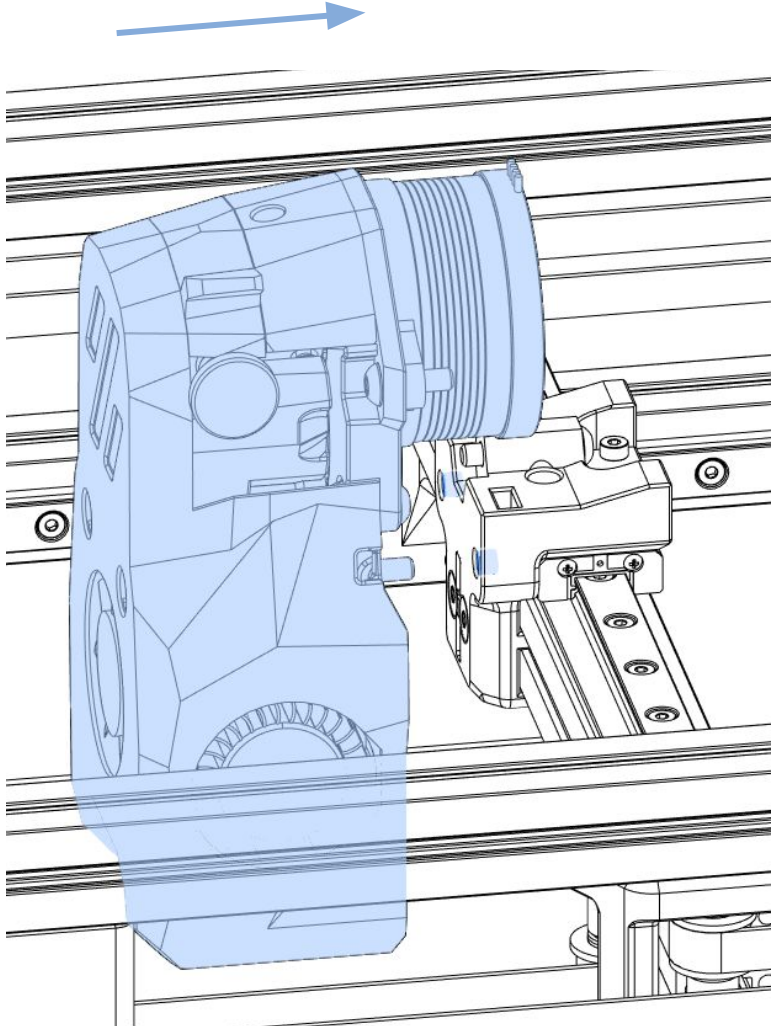

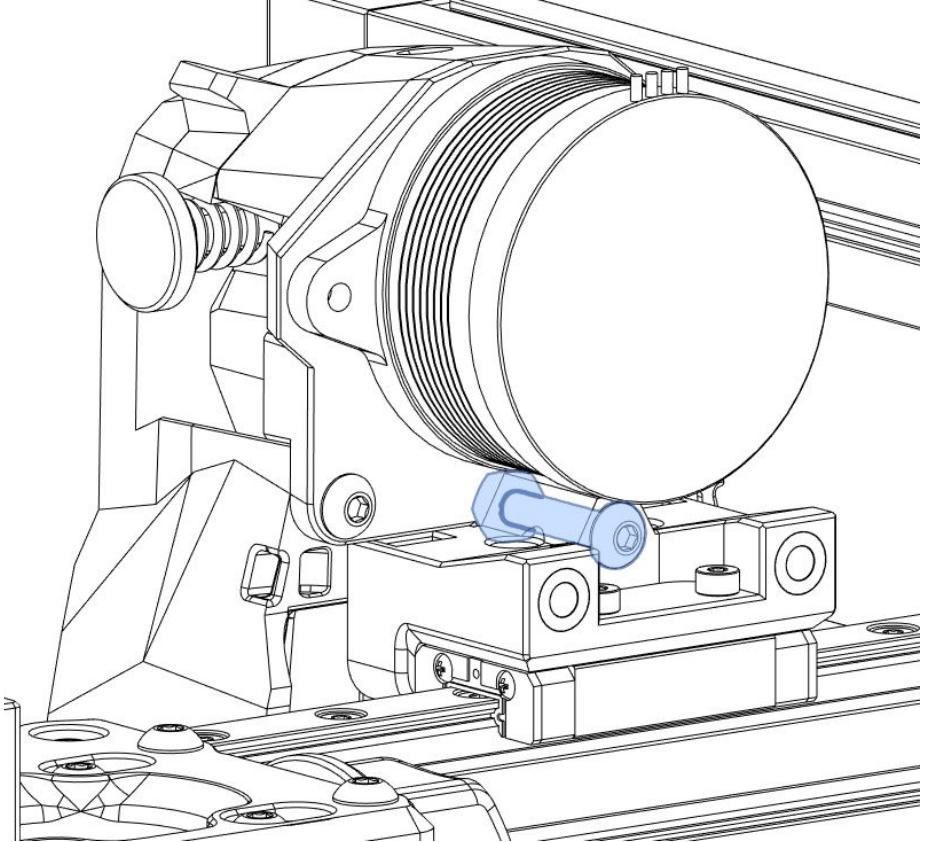
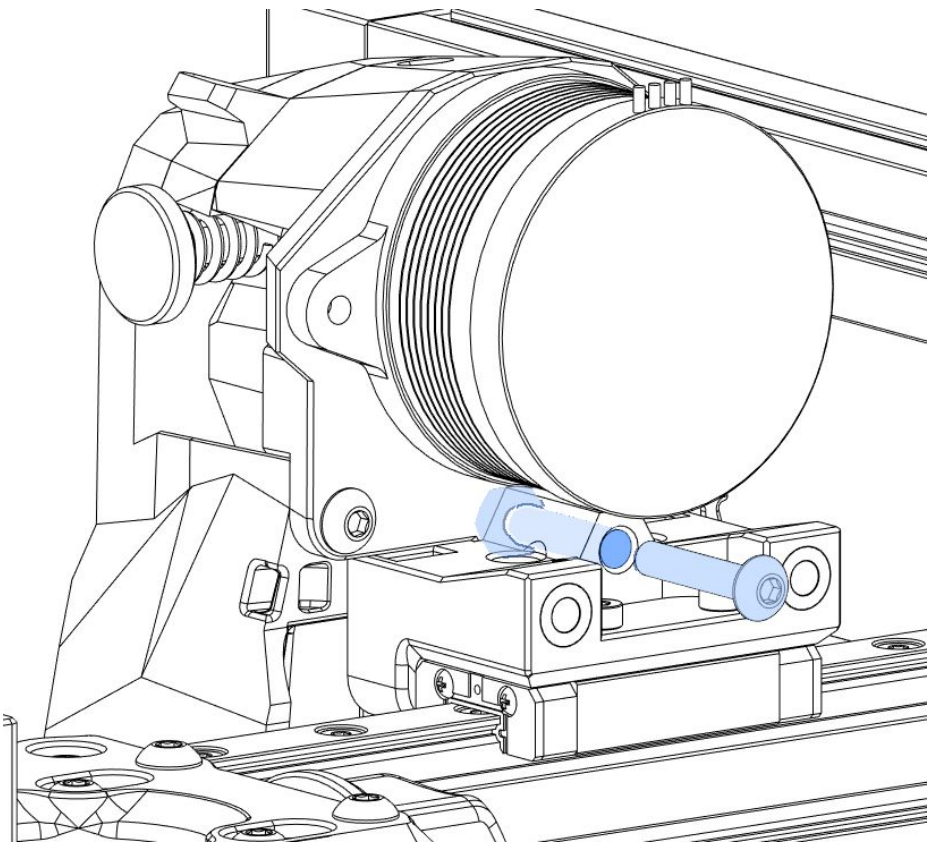

M3x16 BHCS

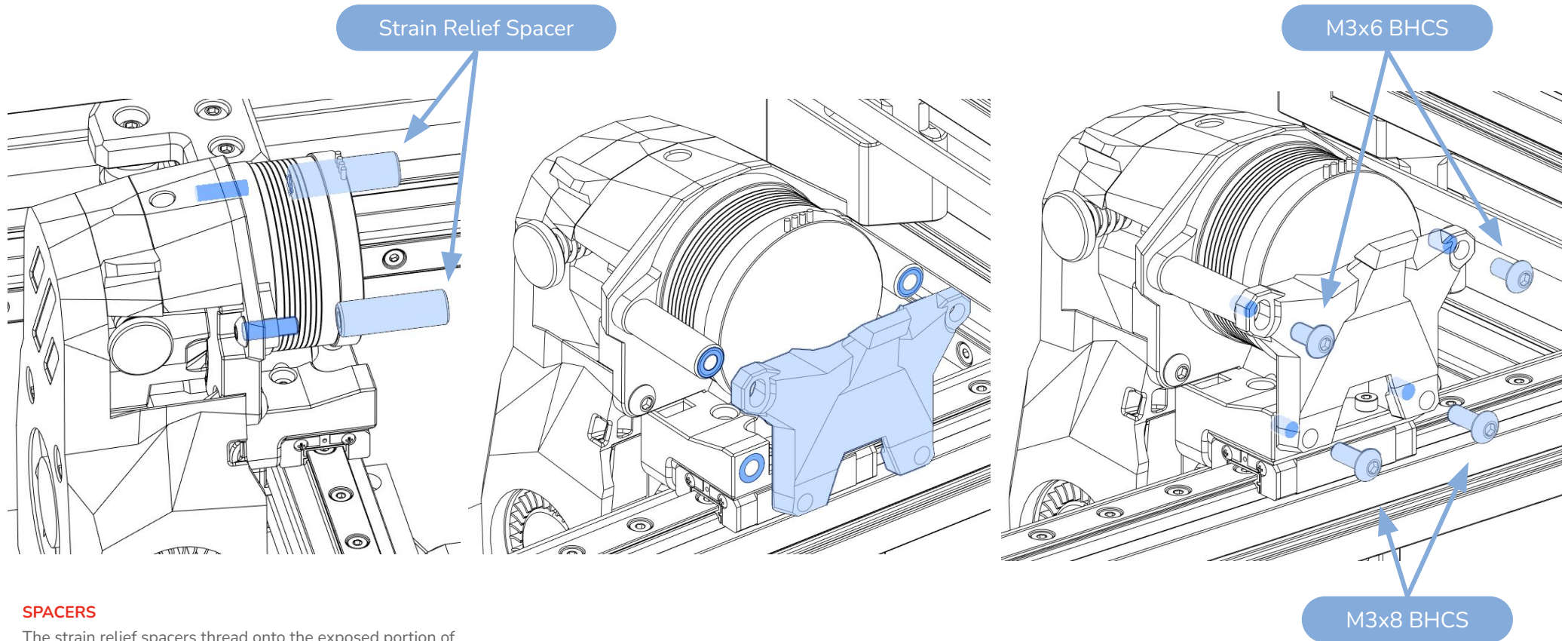

SPACERS

The strain relief spacers thread onto the exposed portion of these two M3x10 BHCS that were installed earlier. If you are having trouble with breaking the spacers, metal version are commonly sold online "20mm m3 standoffs"

CABLE MANAGEMENT

There are loops for zip-ties on either side of the toolhead and a strain relief section on the top.

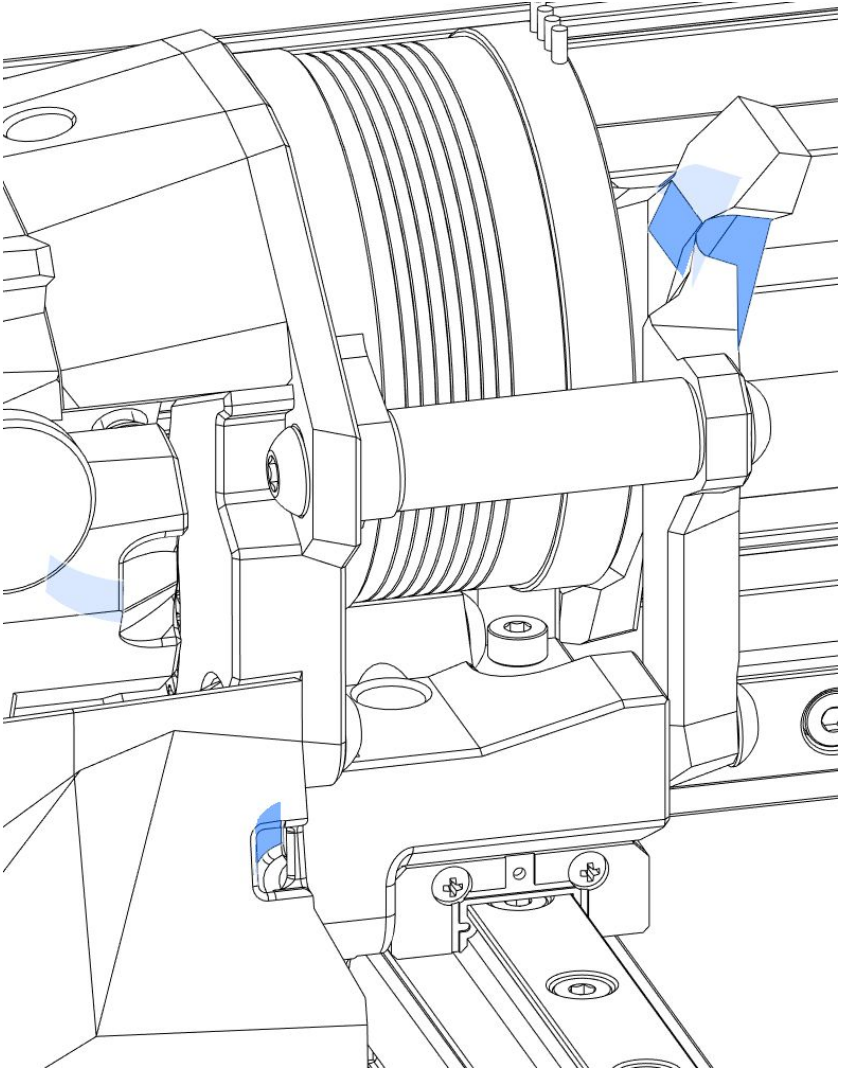

UMBILICAL LENGTH

Wire length from the toolhead to the motor plate is **about 200mm**. Extra length is wasted length. The wires should have minimum slack when the toolhead is at the front of the printer.

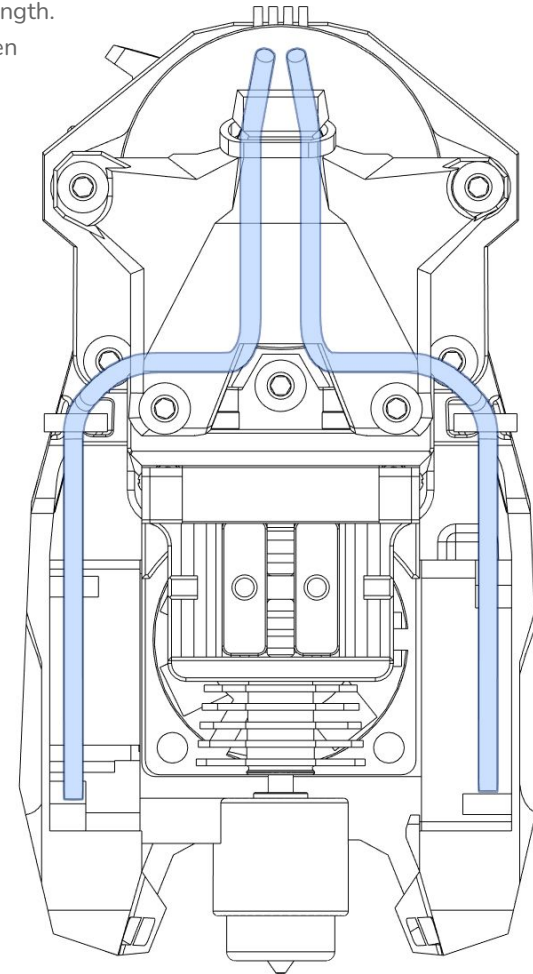
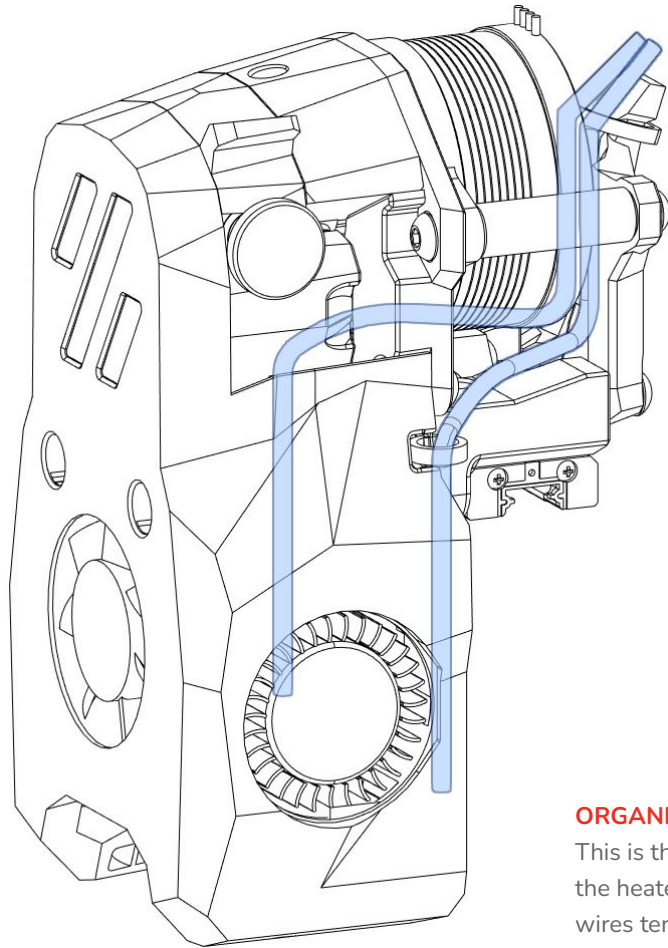

ORGANIZATION IS KEY

This is the intended path for routing cables such as the heater thermistor and fan wires. The heater wires tend to be thicker than other wires so routing them to the opposite side as the thermistor and Hotend fan wires can help keep things balanced.

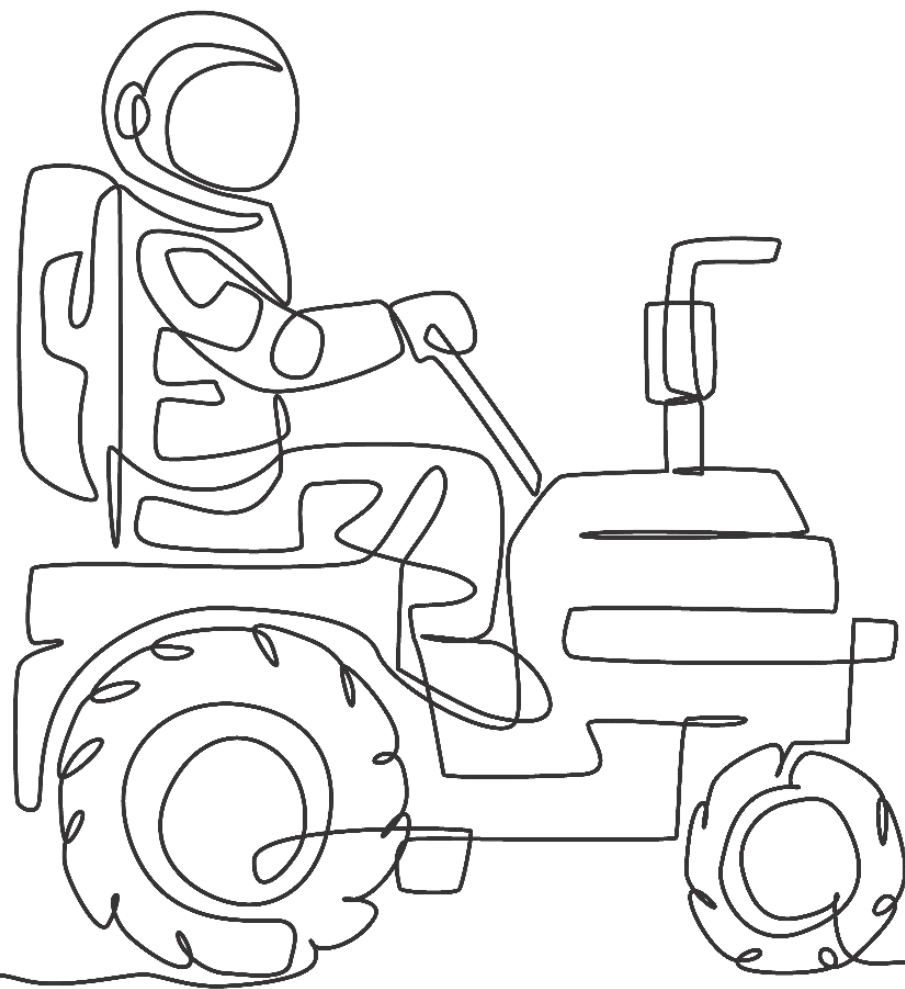

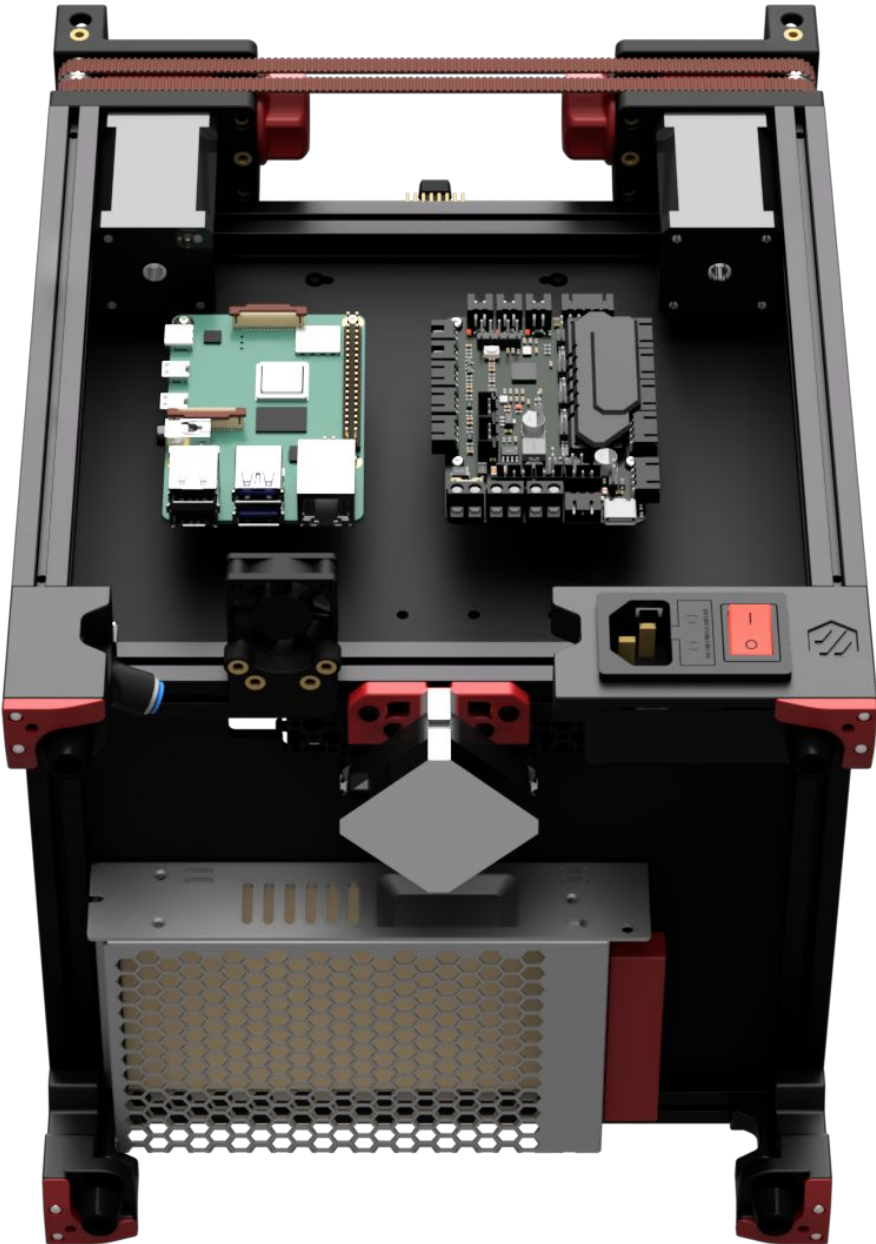

FLIP PRINTER

Aligning the preloaded nuts into position for the mid panel is easier if you don't have to fight gravity. We've highlighted the correct holes here for you.

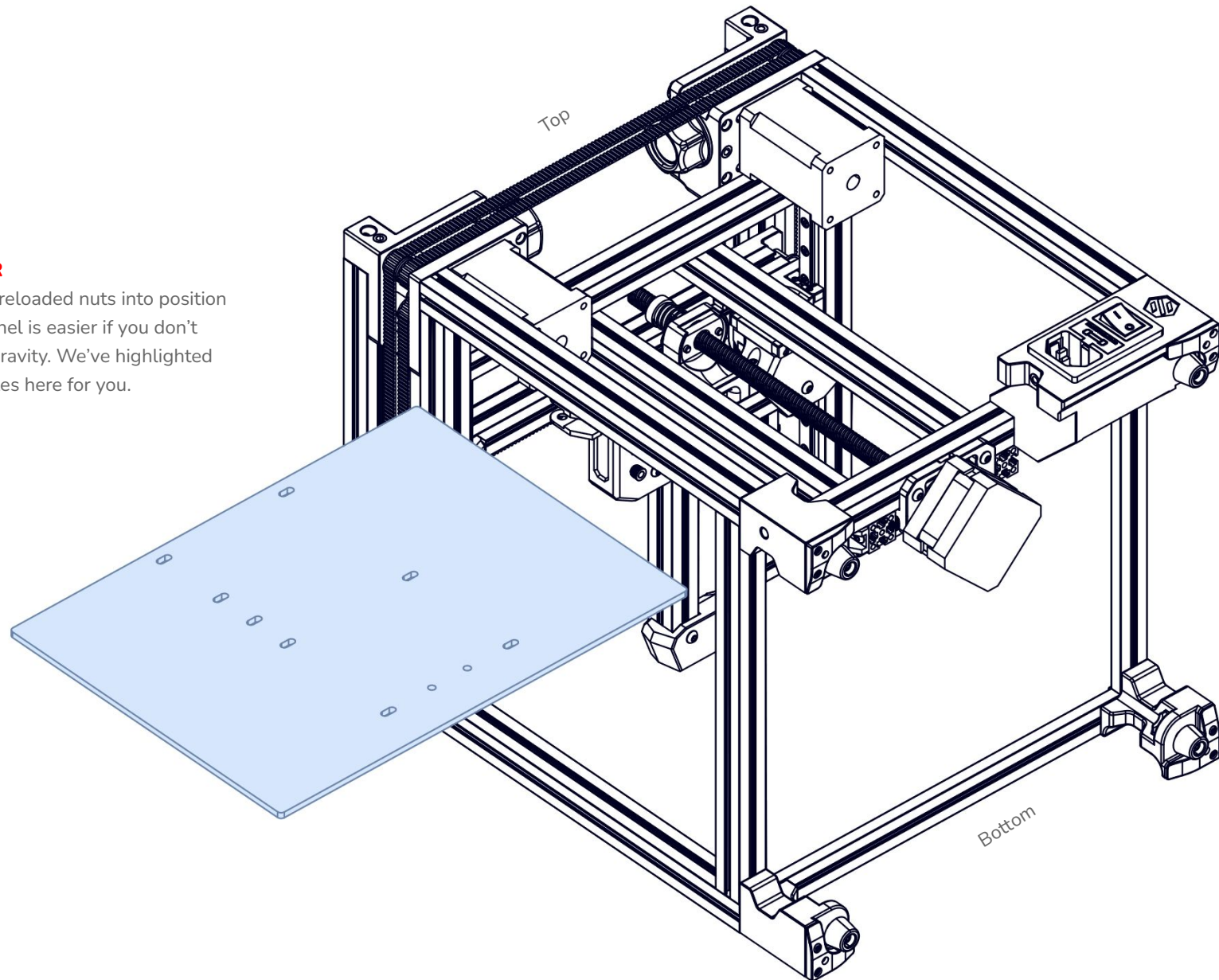

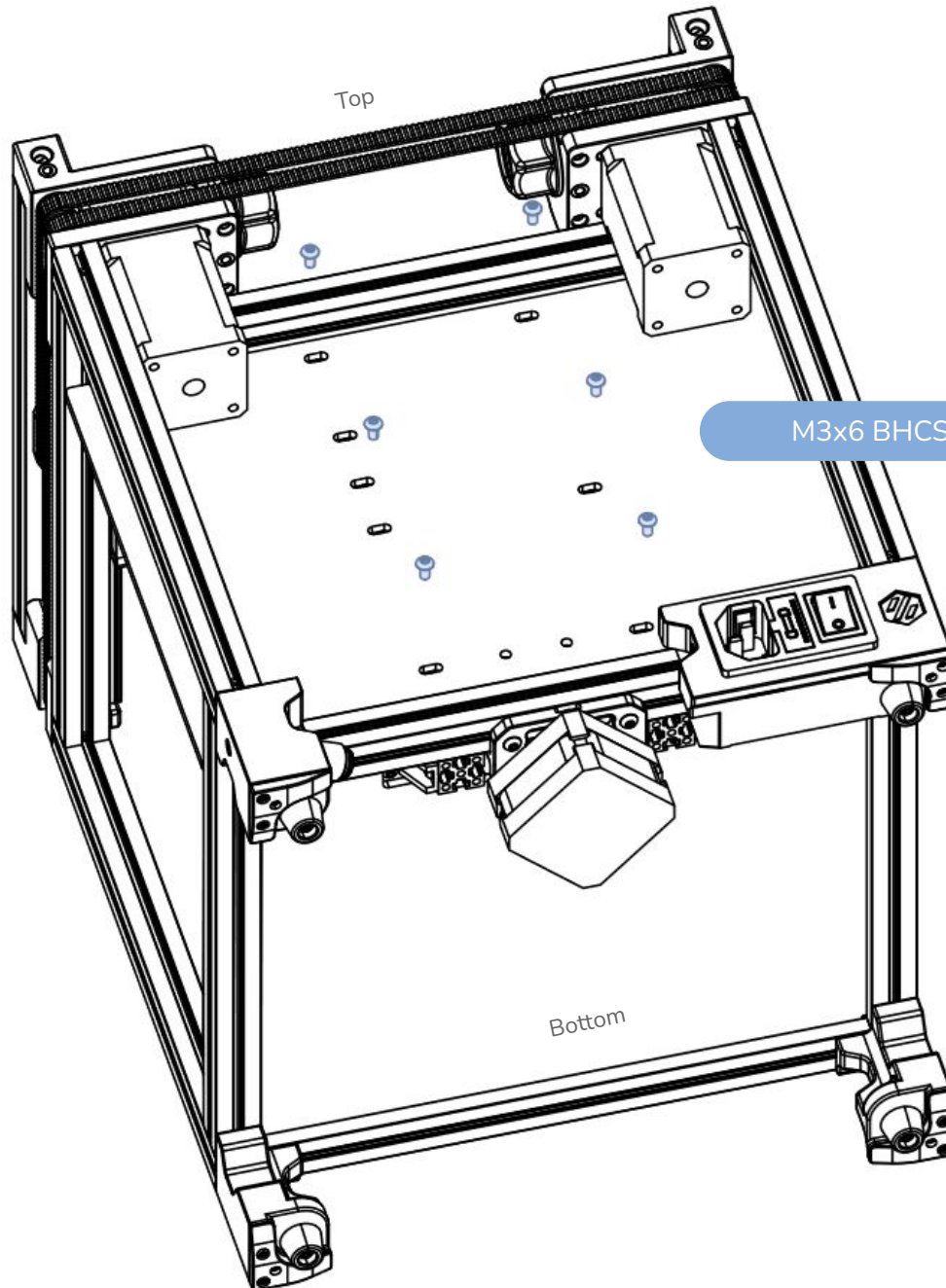
**SECURE THE REAR PANEL**

Secure the rear panel to preloaded nuts. The two empty holes are for the bowden extruder which uses an alternate, older, toolhead.

Attach the DIN cleats in your desired location. Alternatively you can skip the DIN cleats and attach the board mounts directly to the mid-panel.

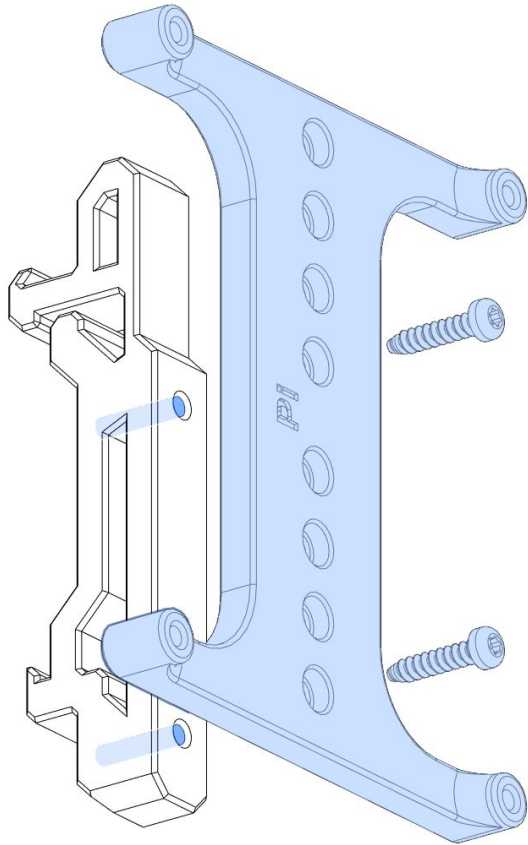

M2x10 Self Tapping

ELECTRONICS MOUNTS

Prepare as many electronics mounts as you need for mounting your MCU and Raspberry Pi. Most builds will require two mounts.

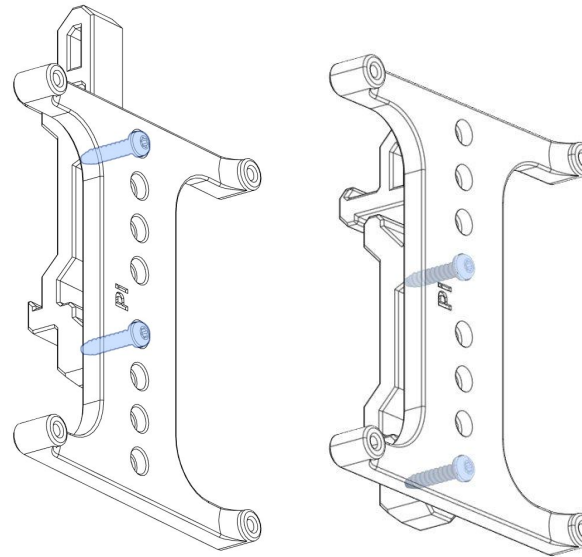

BOARD POSITIONING

You can adjust the vertical location of your control board and Pi by selecting different mounting holes along the part.

Heat Set Inserts

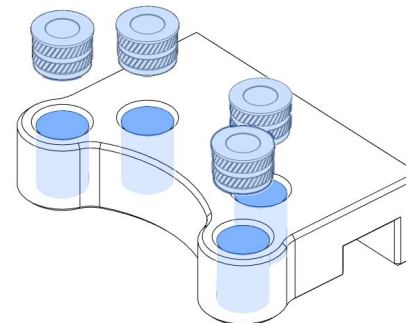

DIN Cleat

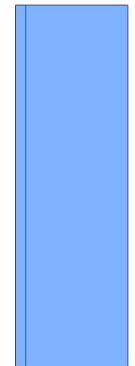
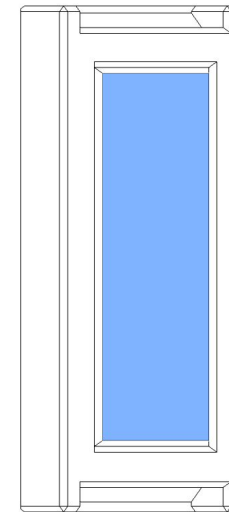

3M 5952

YOU GET A VHB! AND YOU GET A VHB!

If you do not want to use the DIN clips and cleats, you can alternatively attach the board mount directly to the mid-panel with VHB tape. Check you electronics positioning prior to sticking them down

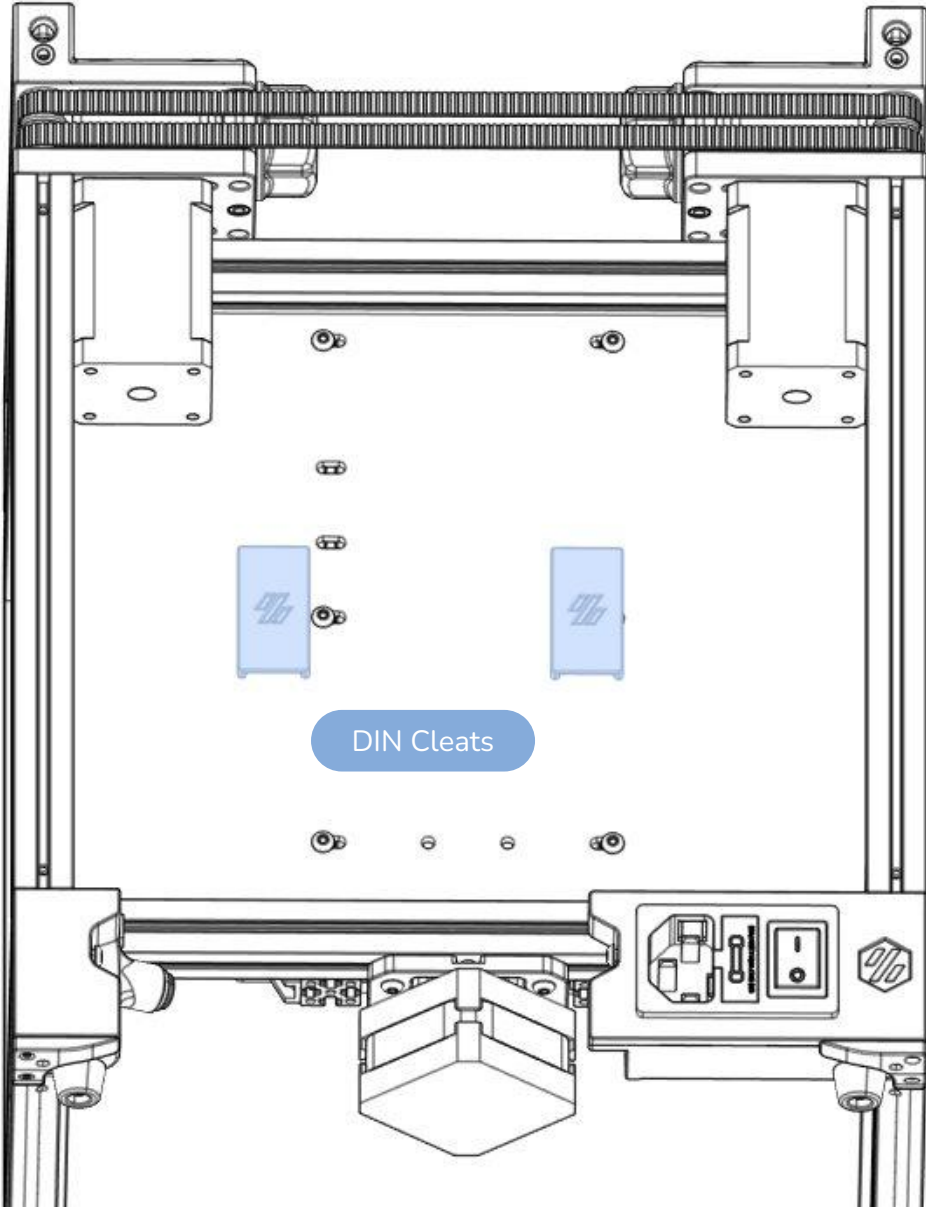

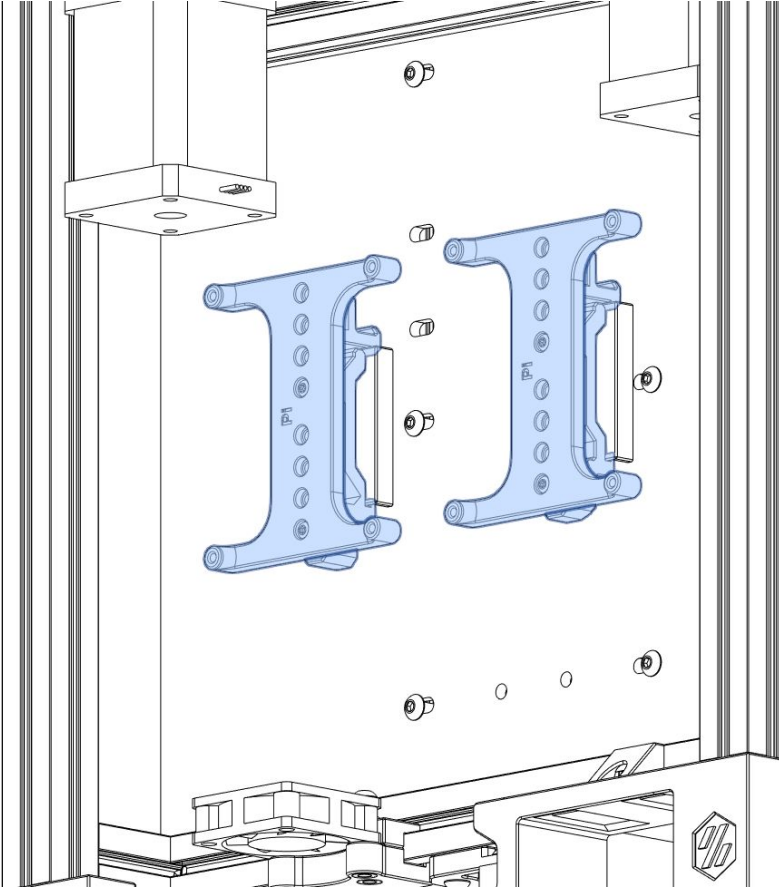
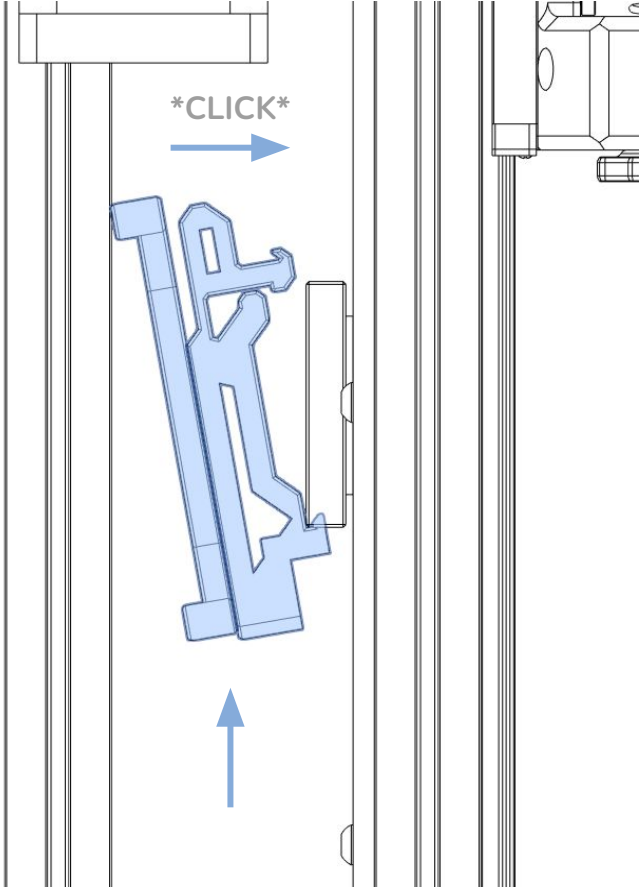

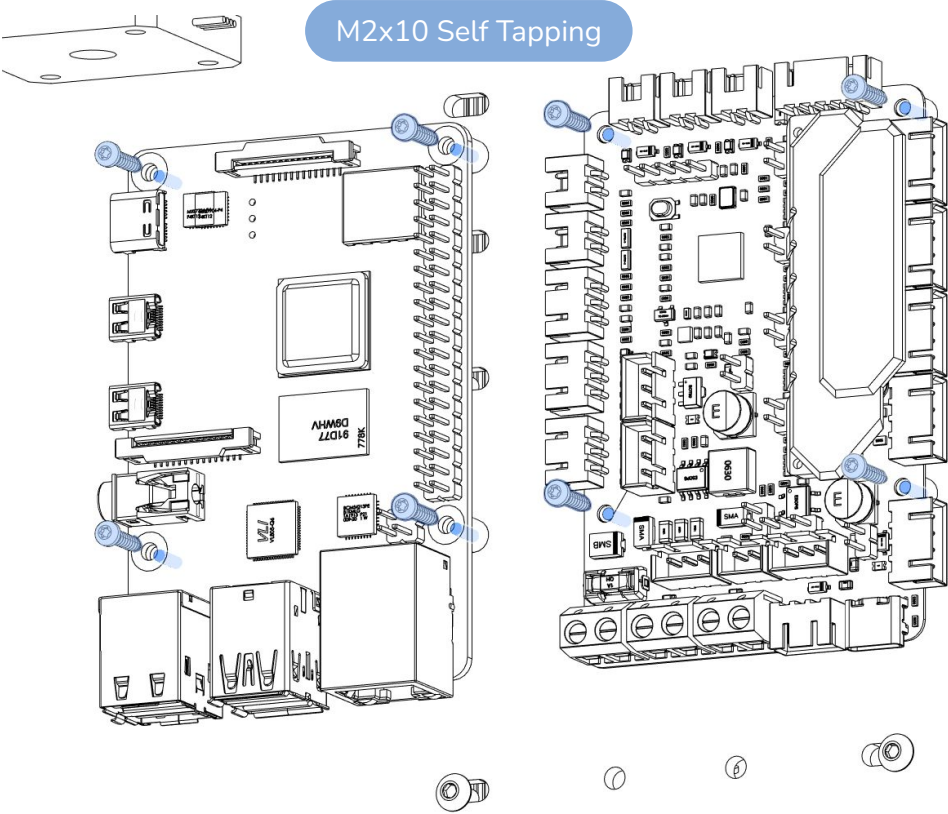
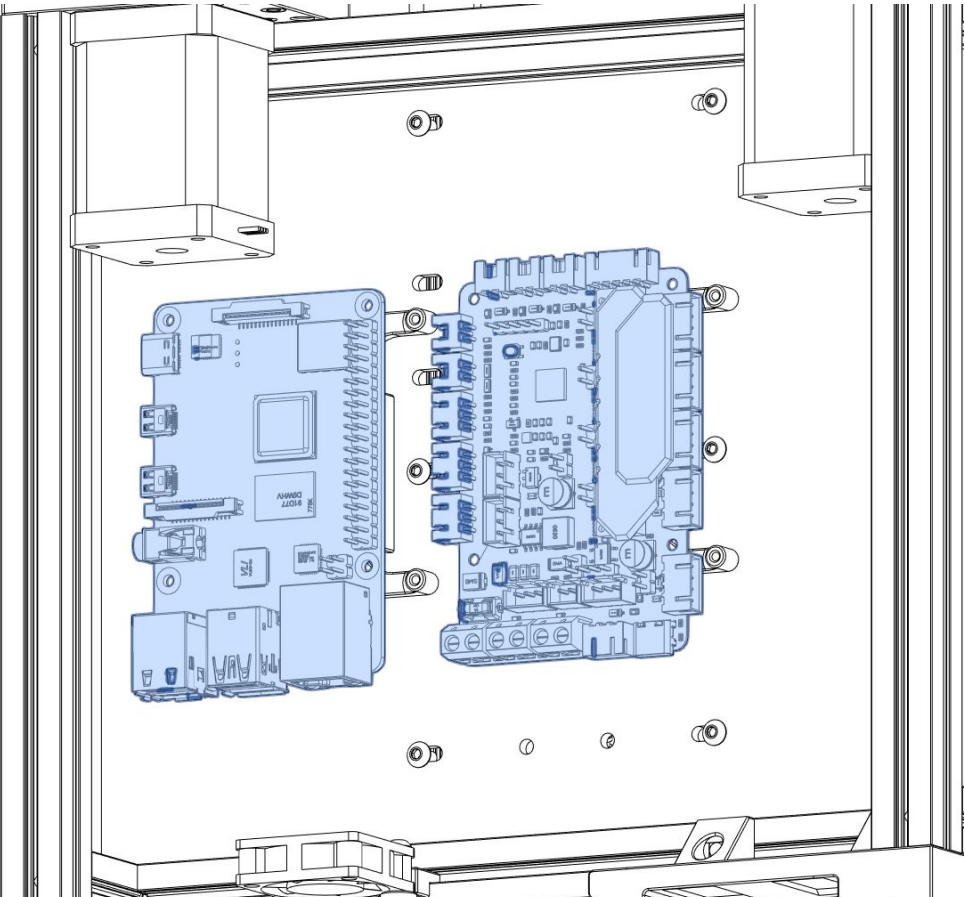

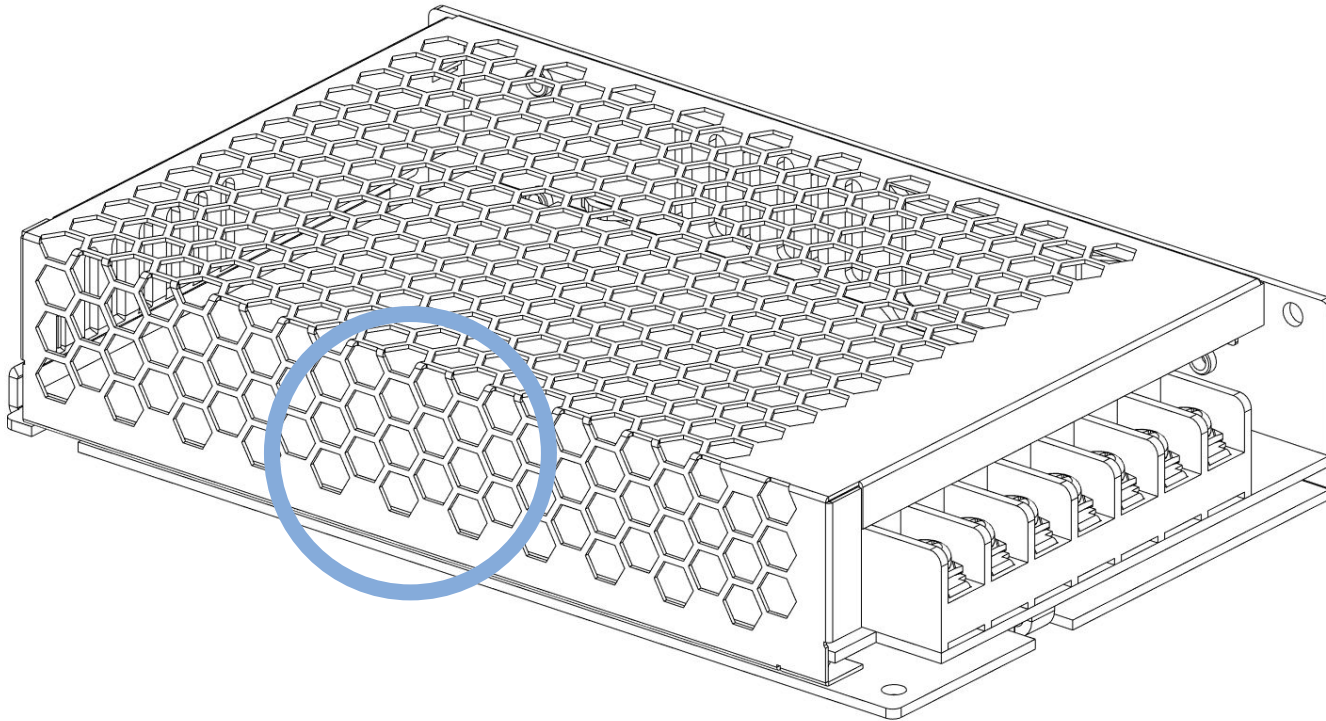

INPUT VOLTAGE SWITCH

Check if there is an input voltage selection switch on your power supply. If there is one, they are typically located in the highlighted area behind the metal mesh, or there will be a dedicated slot that houses the switch.

Make sure the selection matches your local mains voltage. Refer to the Mean Well LRS-150 datasheet for possible settings (<https://voron.link/ibwf2uu>).

24V Power Supply

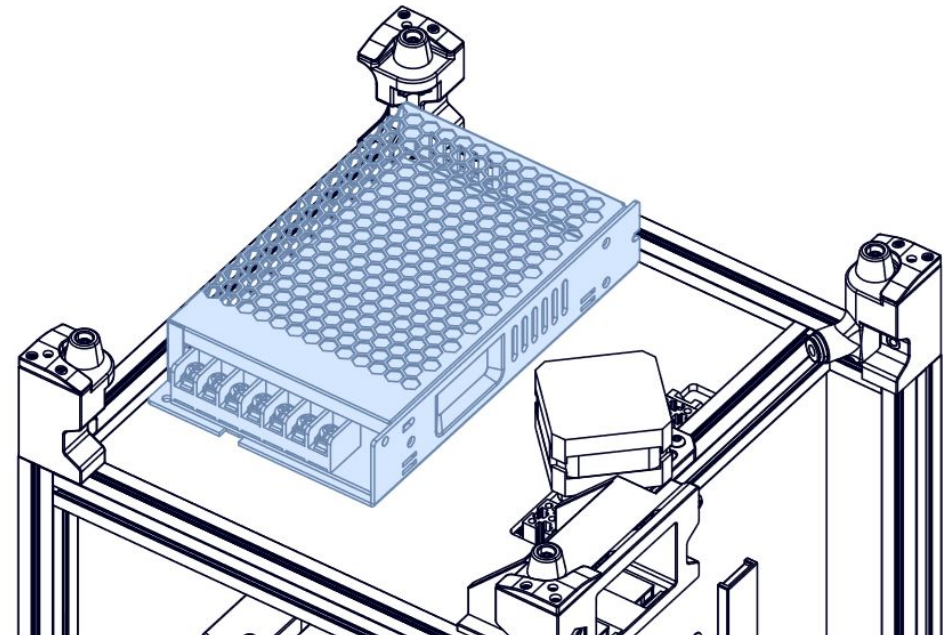
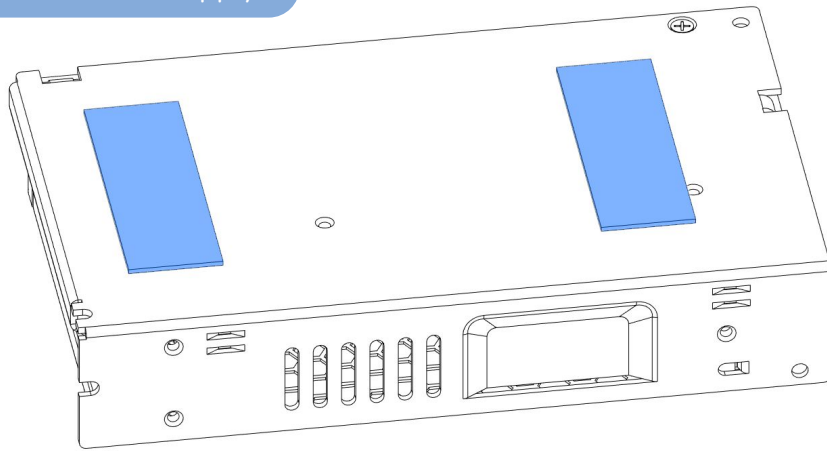
**APPLY VHB TAPE**

3M VHB tape is a double sided pressure sensitive adhesive tape. Other vendors have similar products that you can use as a substitute.

Support the deck panel with one hand and firmly press the power supply against the panel to achieve a strong bond. Be sure to leave a 1-2mm gap from the PSU body to the frame as a safety precaution.

Should you distrust modern adhesives you can alternatively mount it by drilling 2 holes in the deck panel and securing it with 2 M3x6 BHCS. Refer to the LRS-150 datasheet for the hole spacing dimensions (<https://voron.link/ibwf2uu>).

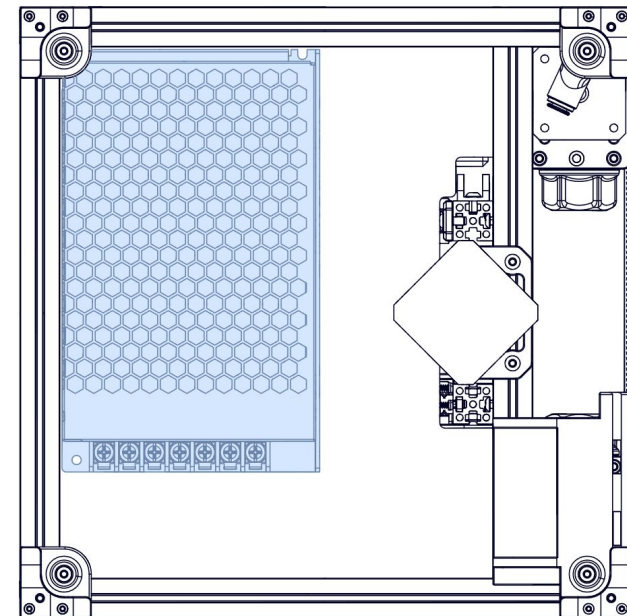

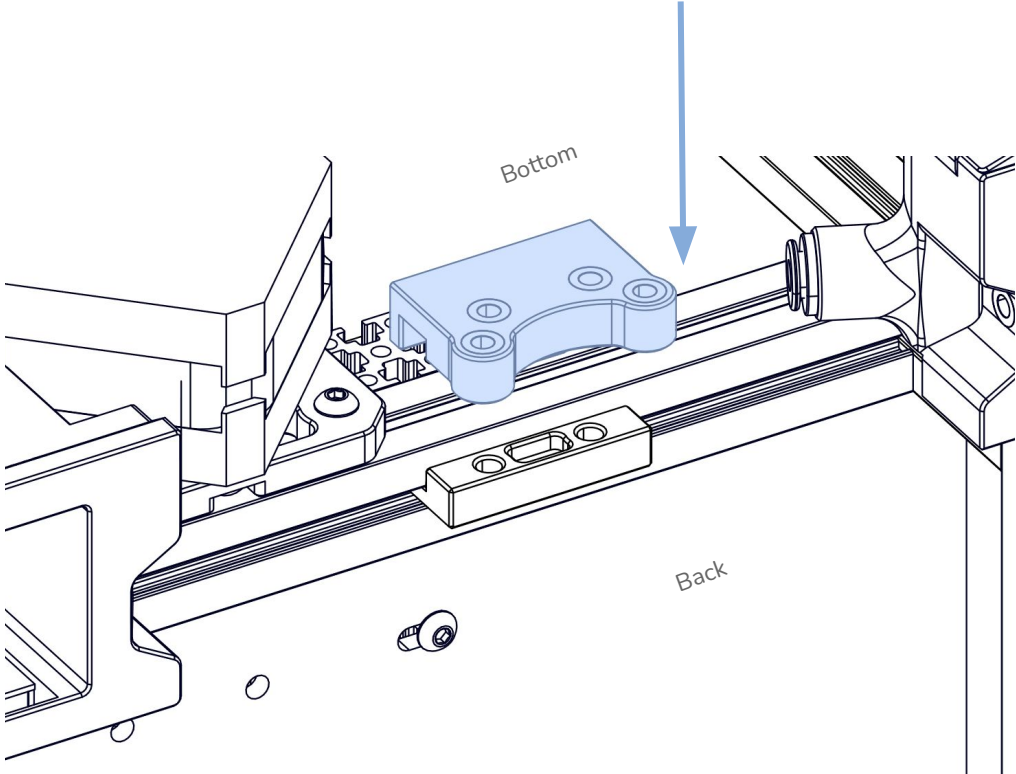
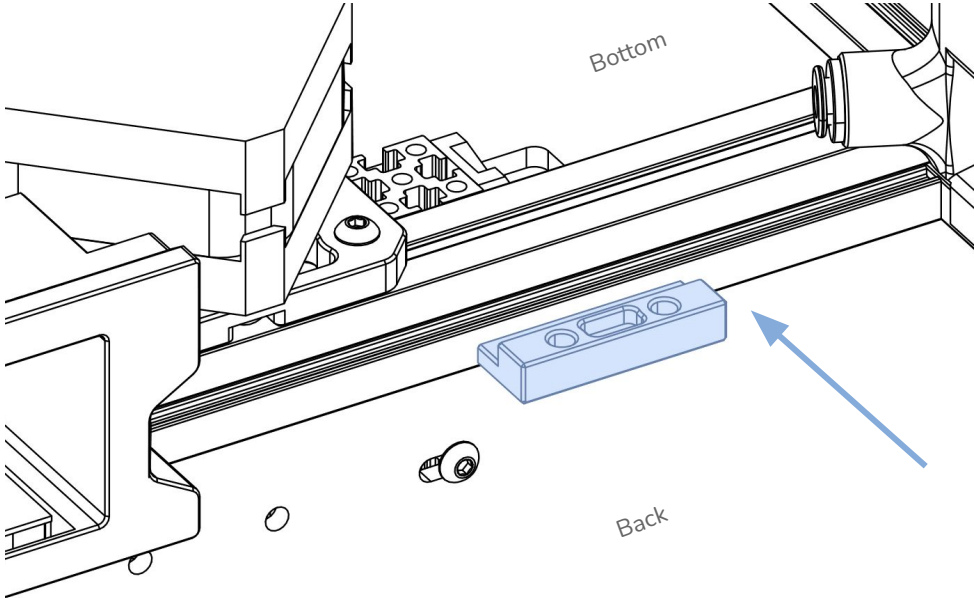

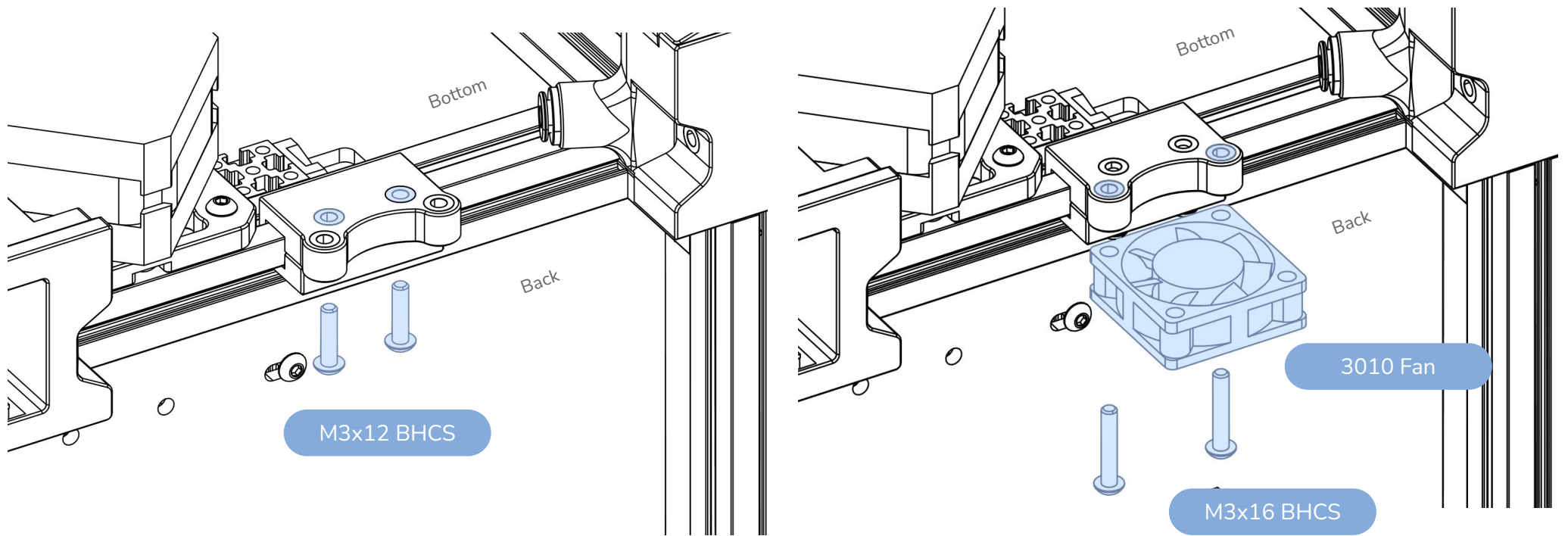



ATTENTION

We are about to enter the section of the manual that involves AC and DC electrical wiring.

Here be dragons.

However, the machine is generally considered safe as long as it remains **unplugged**. So, before powering it on for the first time, **double check** this section and **be sure** you are ready to do so.

If there is something you are not sure about, please reach out. There is no such thing as a dumb question, only a dumb answer.

Let's get started!

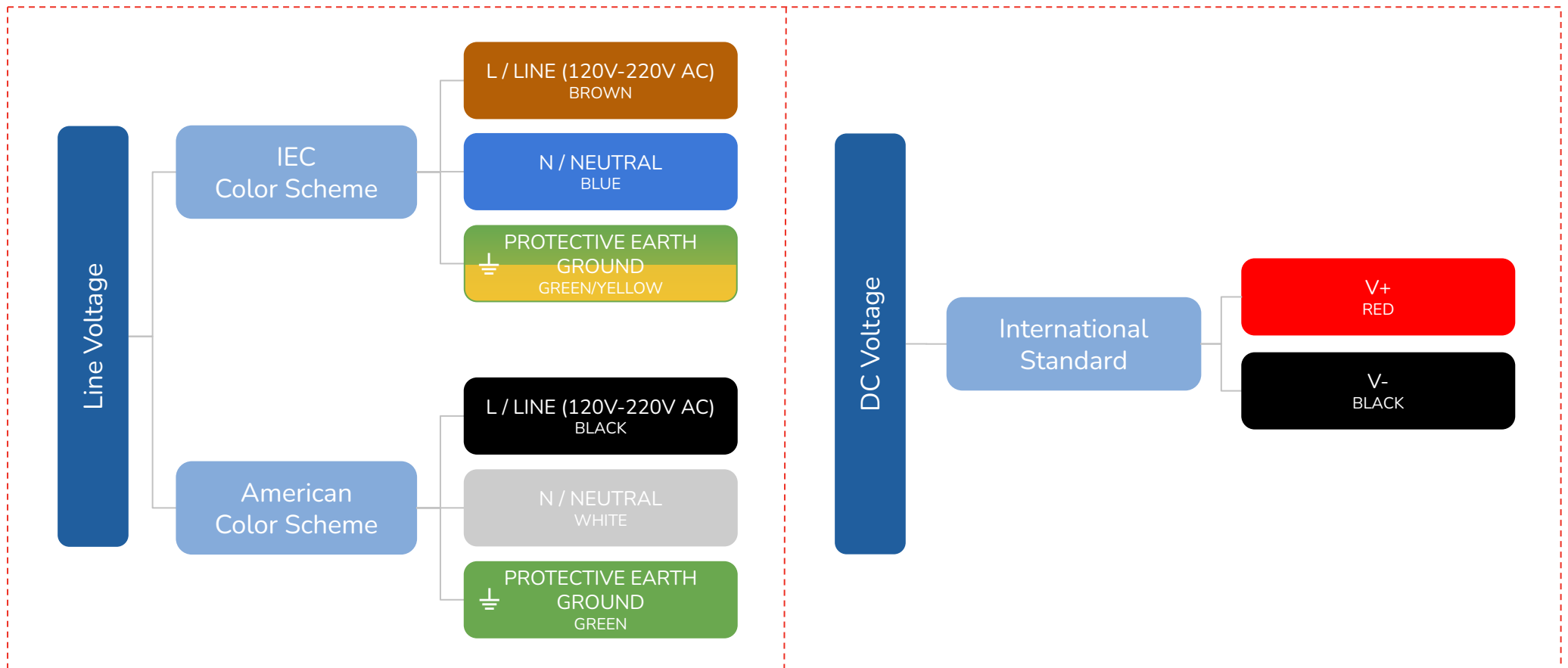

LET'S JUST BE FRIENDS...

At no point whatsoever should you mix AC and DC voltage. All the line voltage should be doing is powering the **DC** power supply in your machine, or powering a **MAINS** powered heated bed. Just because your printer's controller board has GND written on it, **do not** assume it means **PROTECTIVE EARTH GROUND**.

Keep **DC with DC**, and **AC with AC**.

MAINS INLET WIRING

We show the wiring in the IEC colour scheme. Depending on your region the colour scheme and wiring standards will differ.

Mains wiring should only be done by qualified personnel trained in local regulations and safety standards.

Failure to observe those could result in bodily harm.

There is no reward for that.

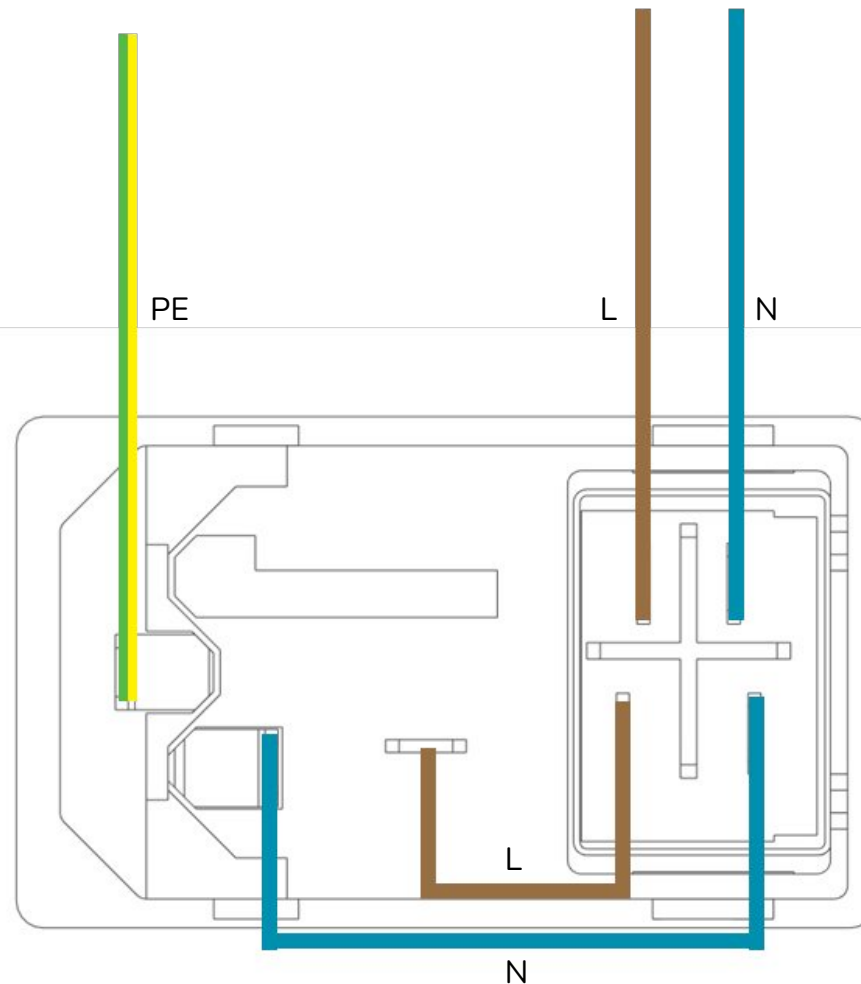
**ATTACH 250mm OF WIRE**

Cables should be at least 0.75mm² (AWG18) or thicker depending on local regulations.

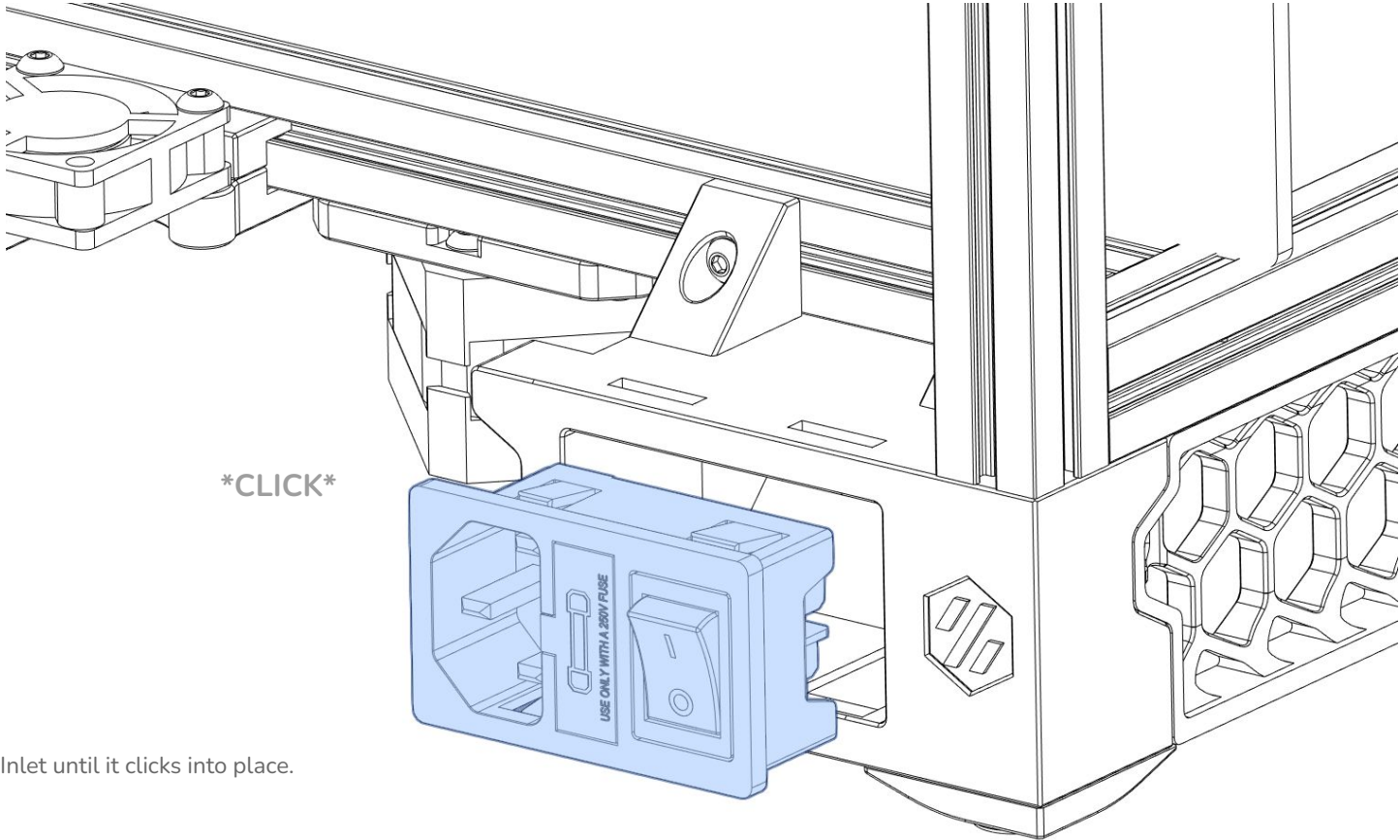

CLICK

SLIDE IT IN
Insert Mains Inlet until it clicks into place.

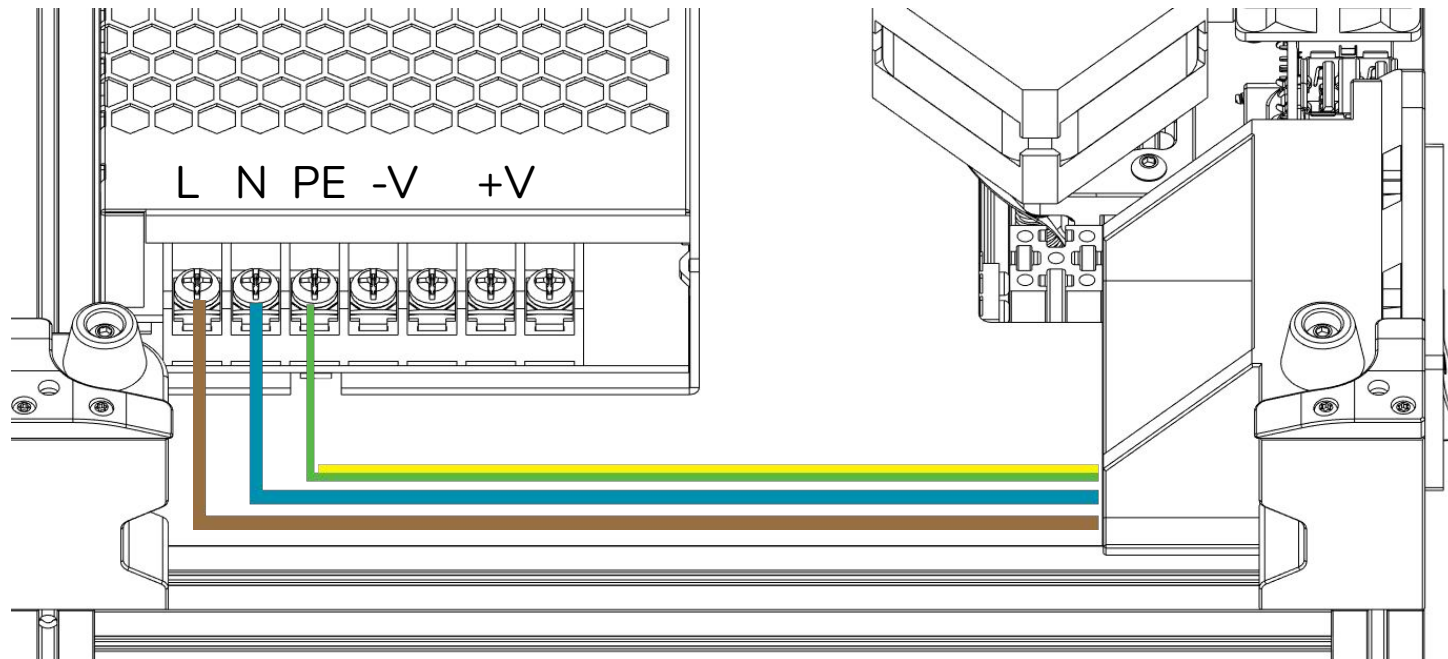

MAINS WIRING

This completes the mains wiring on a Voron V0.2. A guard cover will be installed in a later step. Secure the wires with cable clips / cable tie anchors.

The bed heater is powered by DC voltage, grounding the print bed should not be required. Observe your local regulations in regards to grounding the frame/other components.

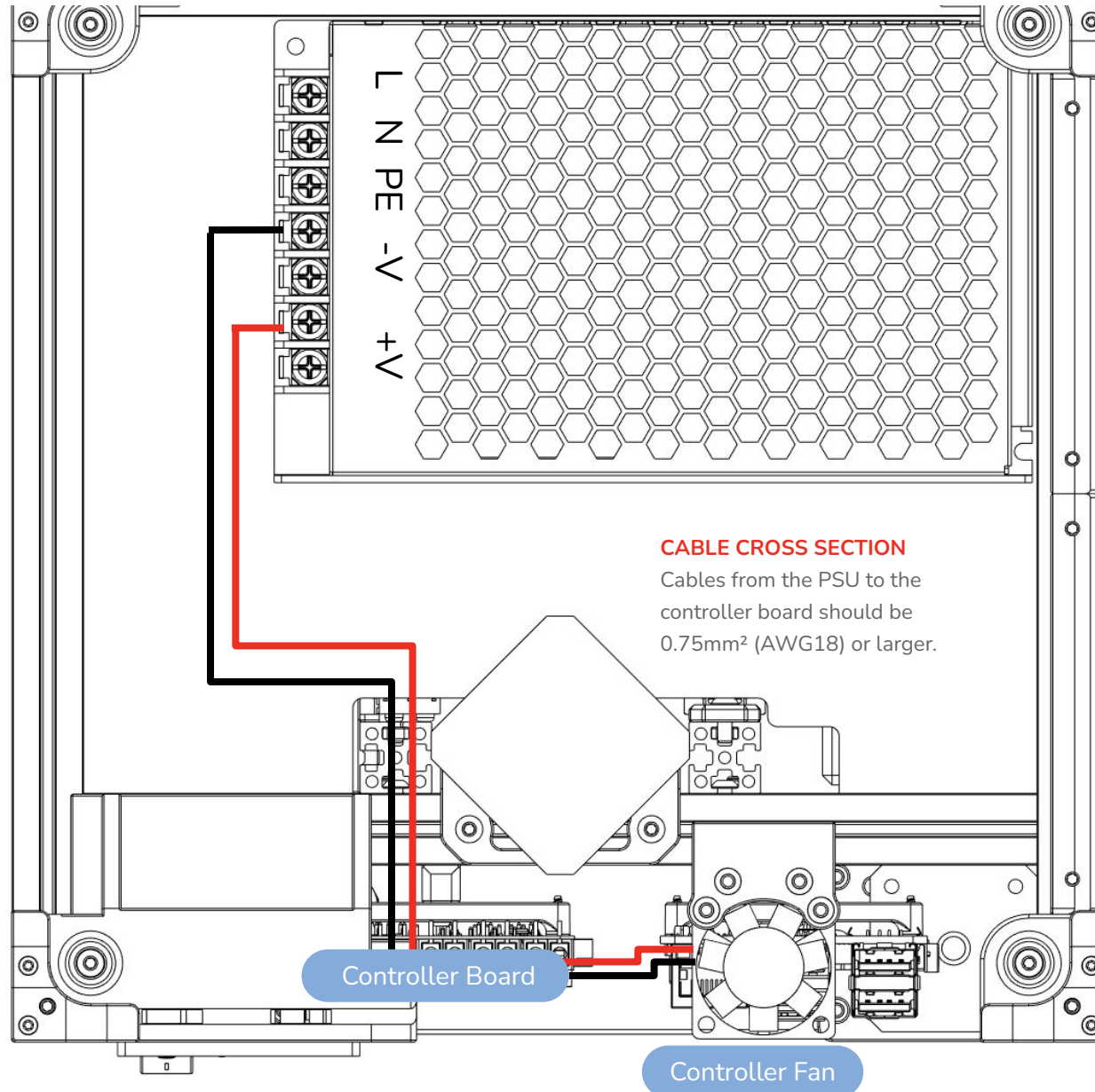

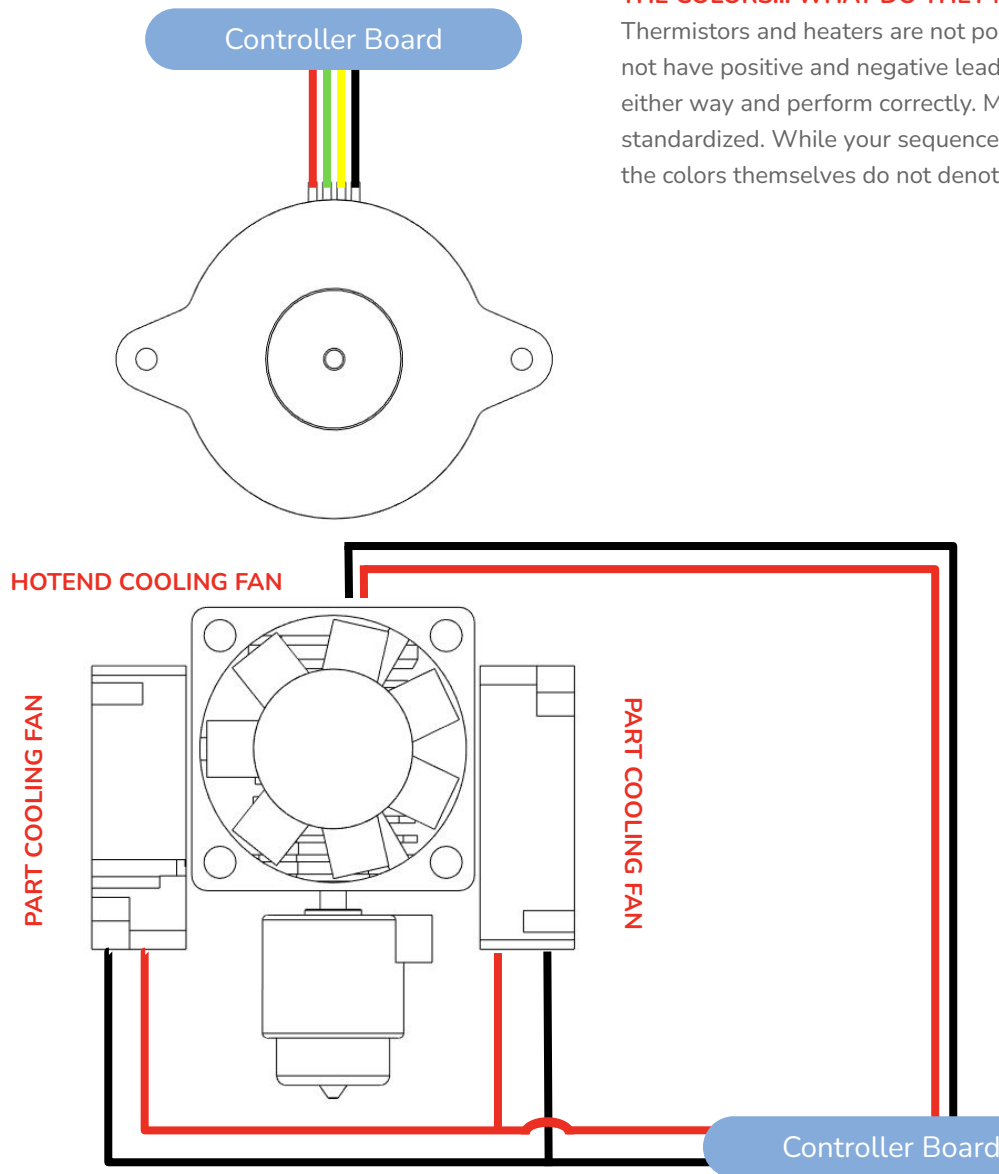

THE COLORS... WHAT DO THEY MEAN!?

Thermistors and heaters are not polarity dependent so they do not have positive and negative leads. They can be hooked up either way and perform correctly. Motor wiring colors are not standardized. While your sequence may match the images, the colors themselves do not denote anything in particular.

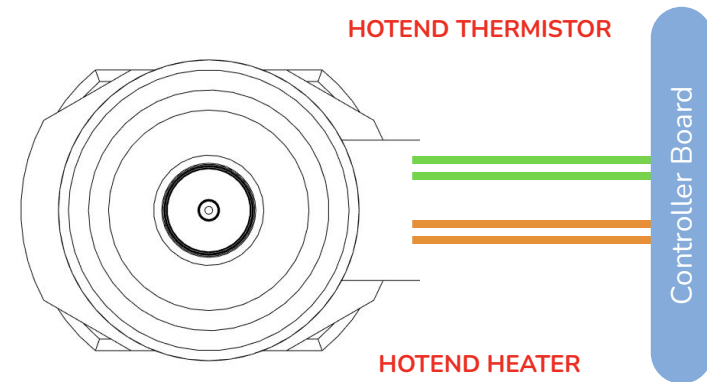

FAN VOLTAGE

The wiring schematic assumes that you sourced 24V part cooling fans and a 24V fan for the hotend.

If you sourced fans with a different operating voltage you'll need to adjust the wiring, see <https://voron.link/5fkzb2e> or check on Discord.

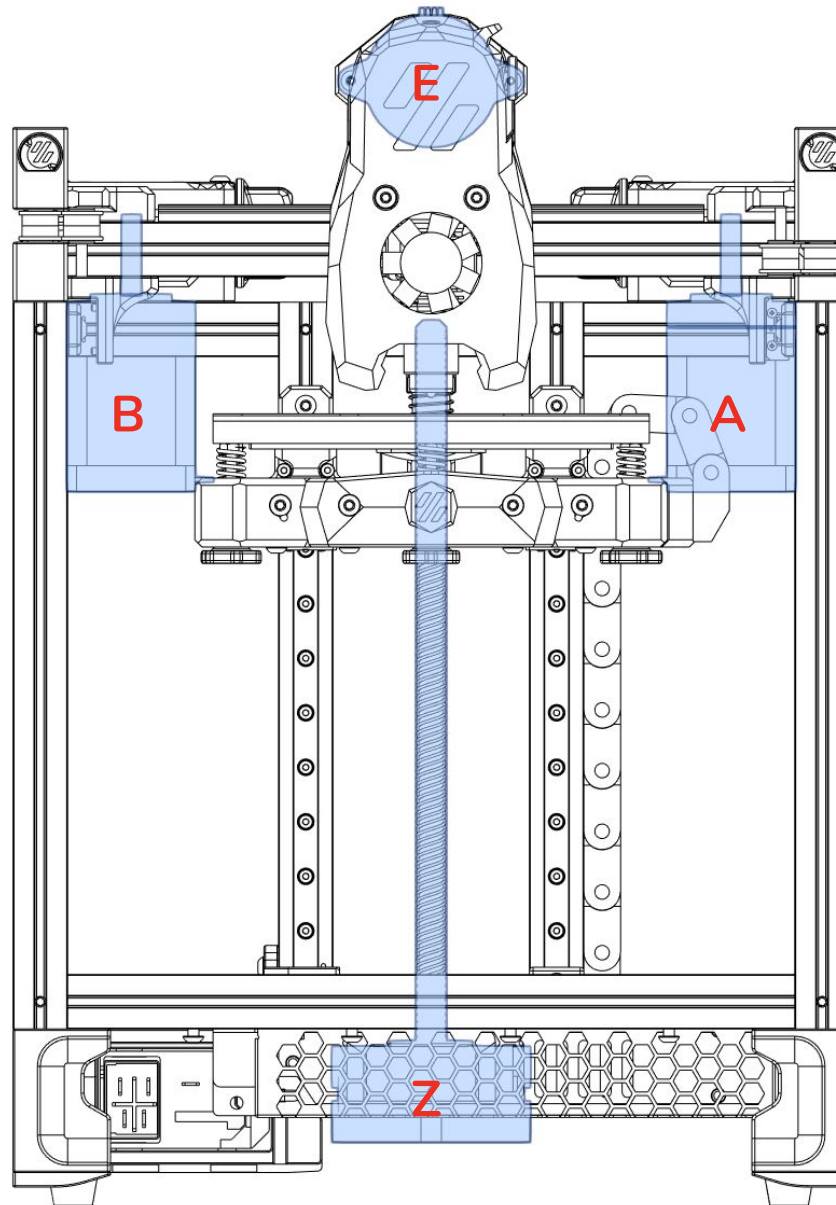
**BA BA BLACK SHEEP**

Take note of the locations of the B (X) Stepper Motor and the A (Y) Stepper Motor as they relate to the wiring instructions.

SKR PICO

This is considered the "Spec" option, the rest of the manual will show this configuration.

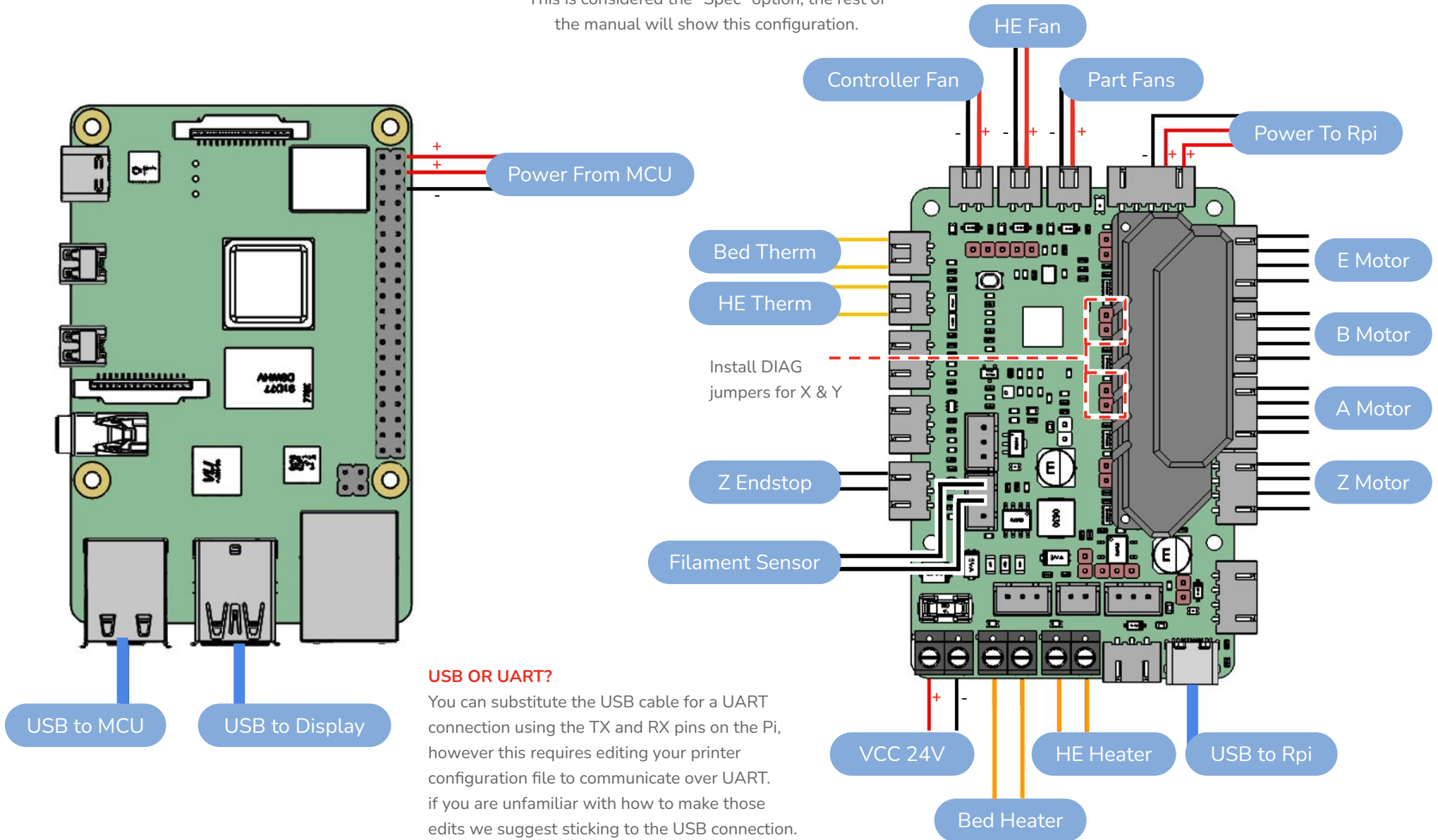

USB OR UART?
 You can substitute the USB cable for a UART connection using the TX and RX pins on the Pi, however this requires editing your printer configuration file to communicate over UART. if you are unfamiliar with how to make those edits we suggest sticking to the USB connection.

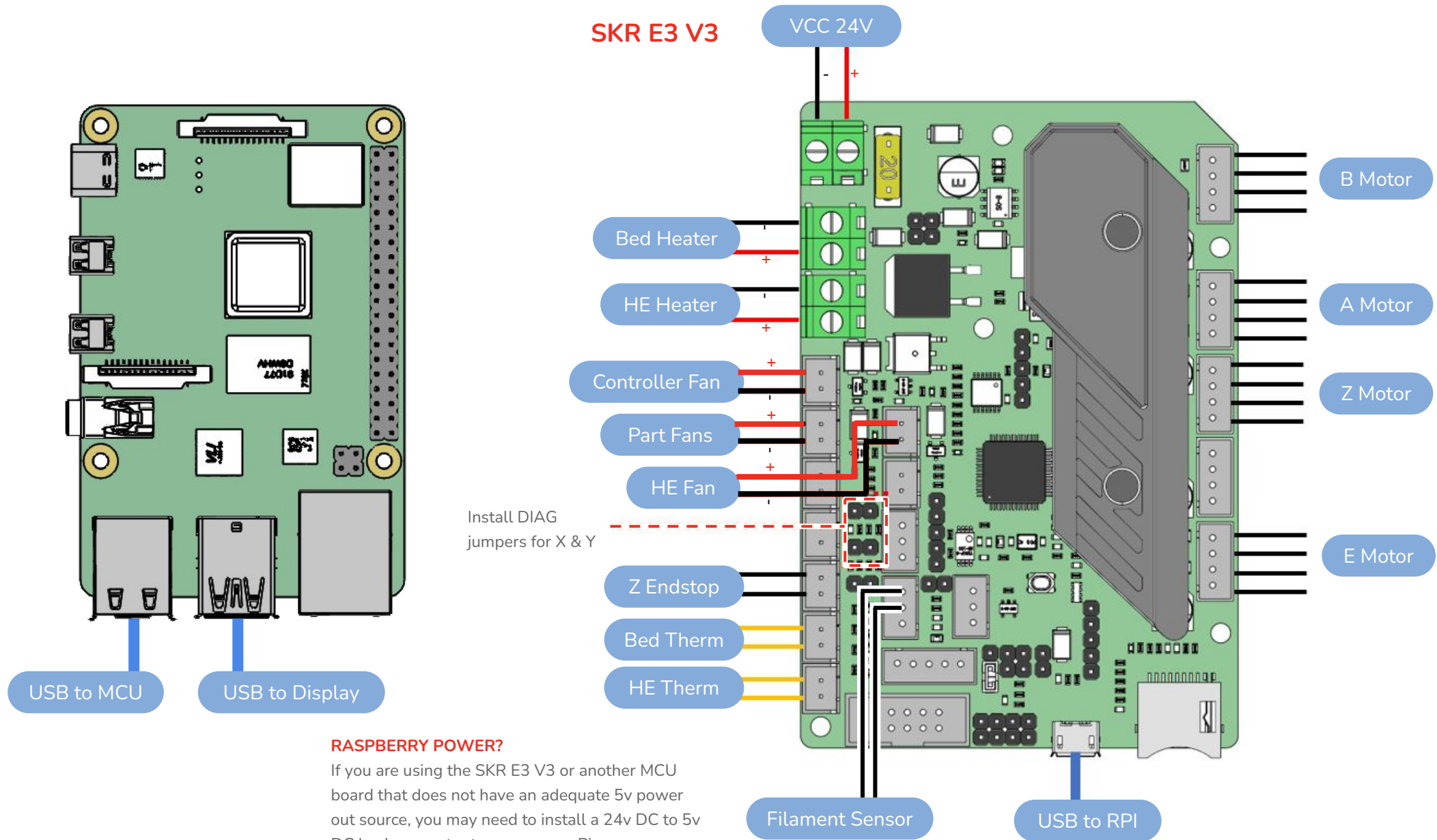

RASPBERRY POWER?

If you are using the SKR E3 V3 or another MCU board that does not have an adequate 5v power out source, you may need to install a 24v DC to 5v DC buck converter to power your Pi.

FINGER GUARD

The guard reduces the risk of accidentally touching the terminals.

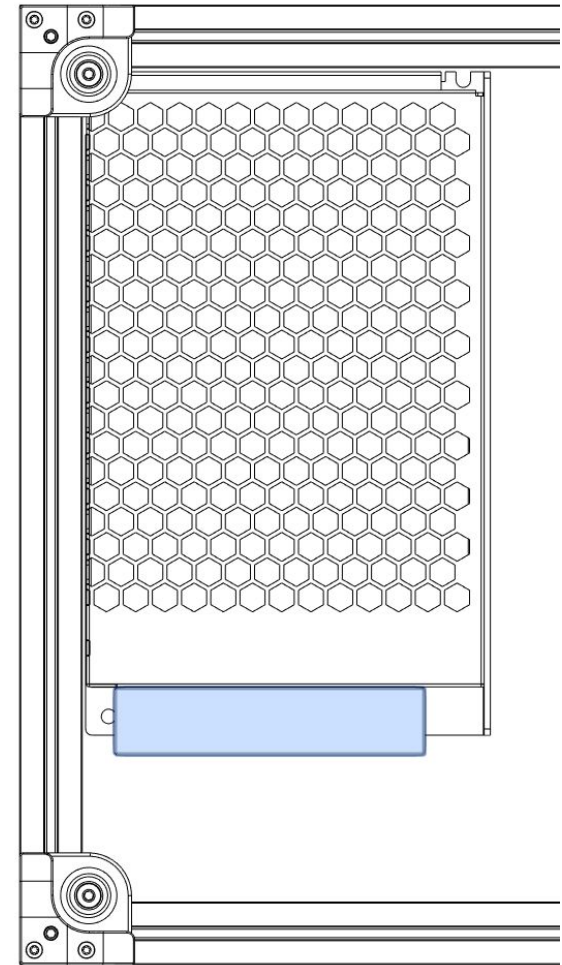
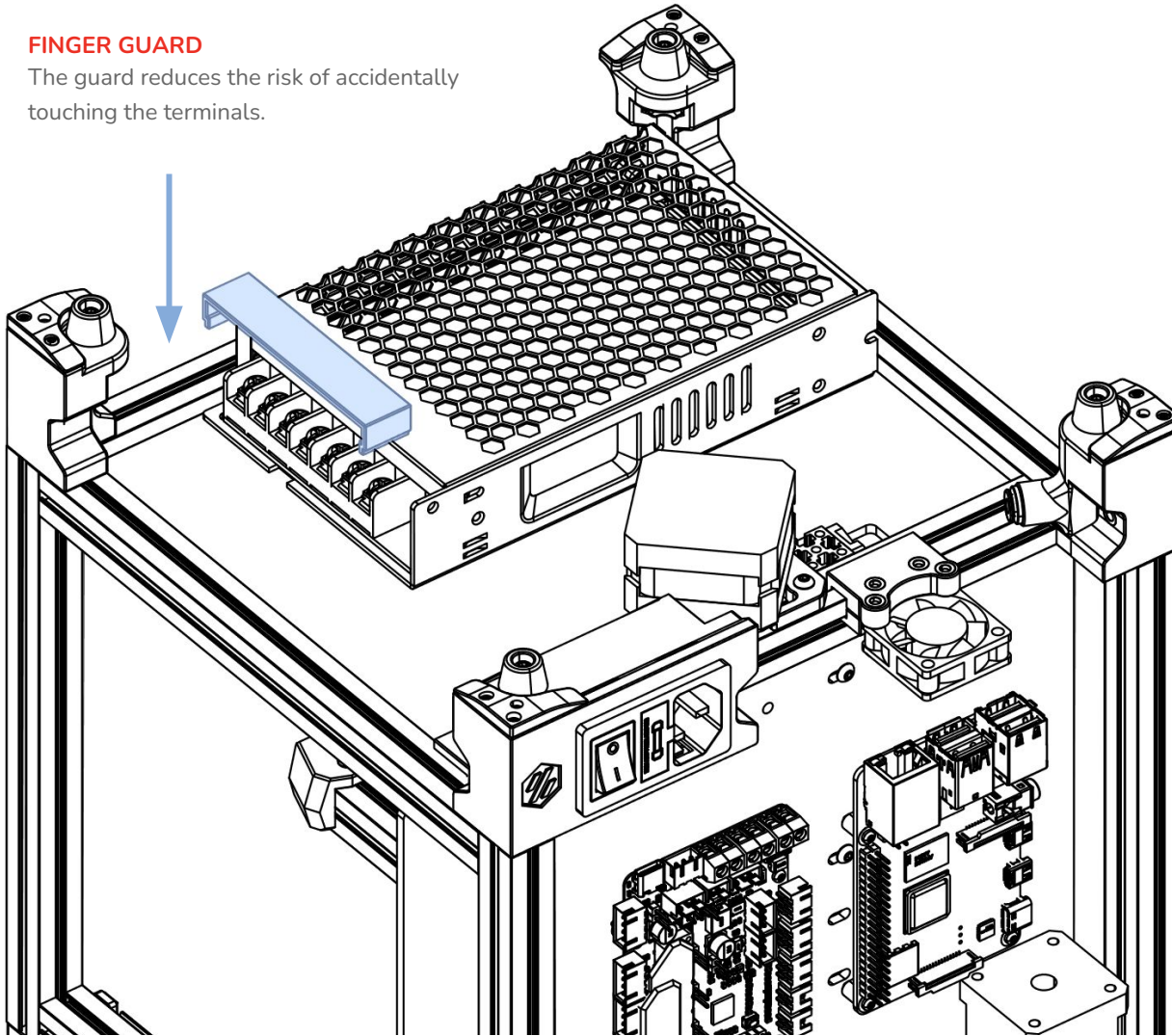

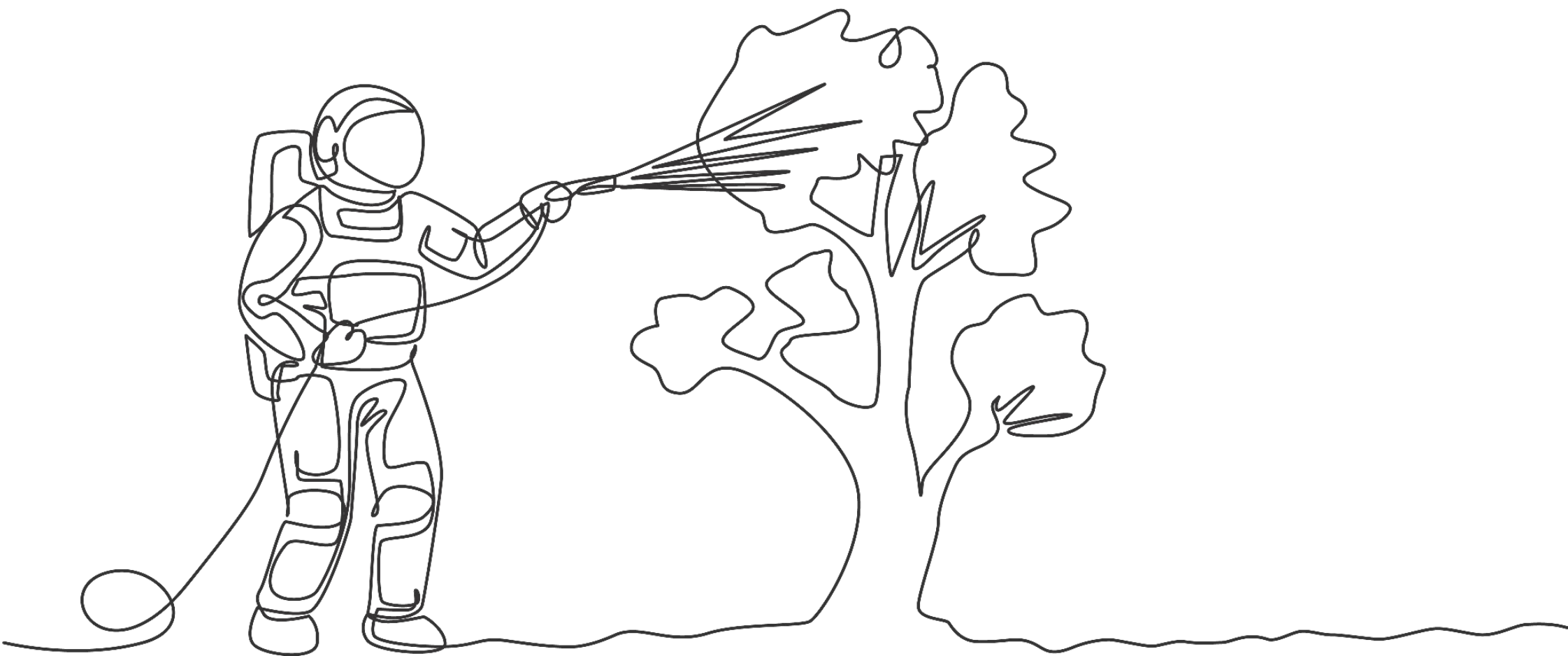



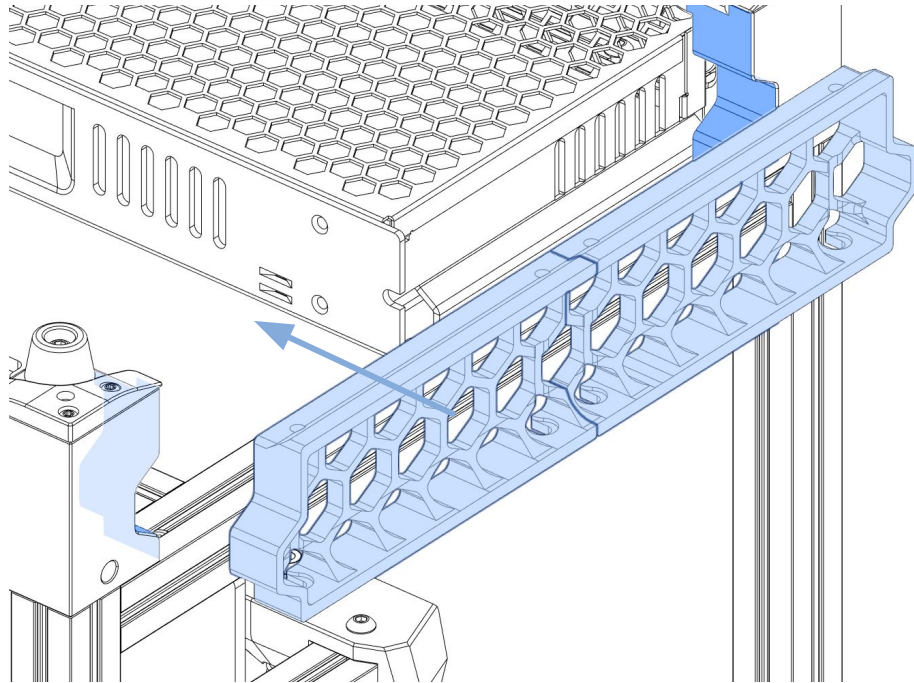

SLOTS FOR ASSEMBLY

The skirt parts contain slots, if you prefer, you can attach the screws to the extrusions first and slide the skirts on prior to tightening down the fasteners.

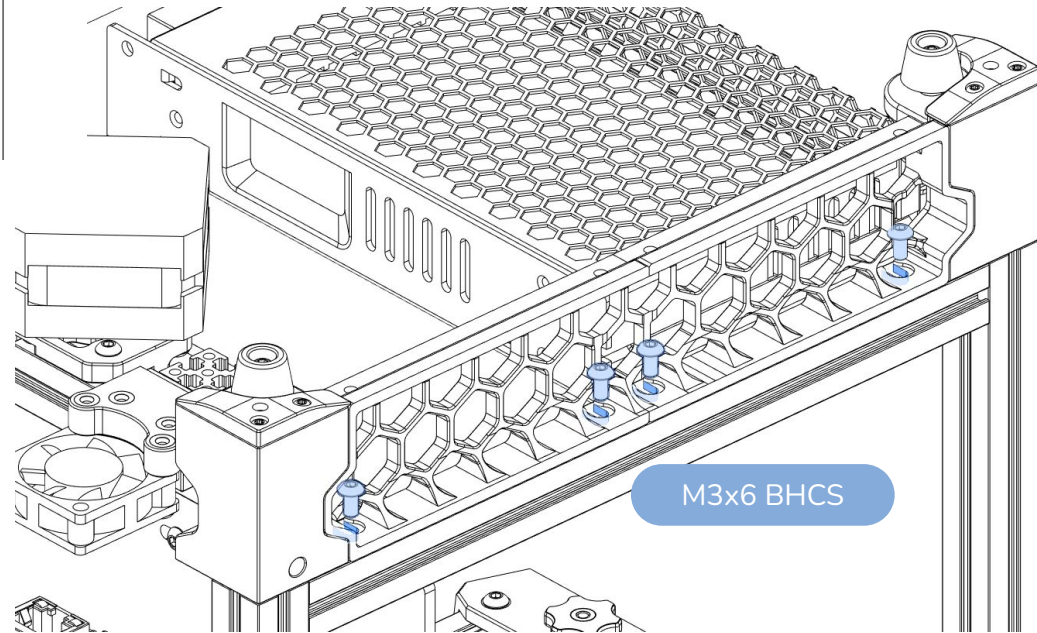

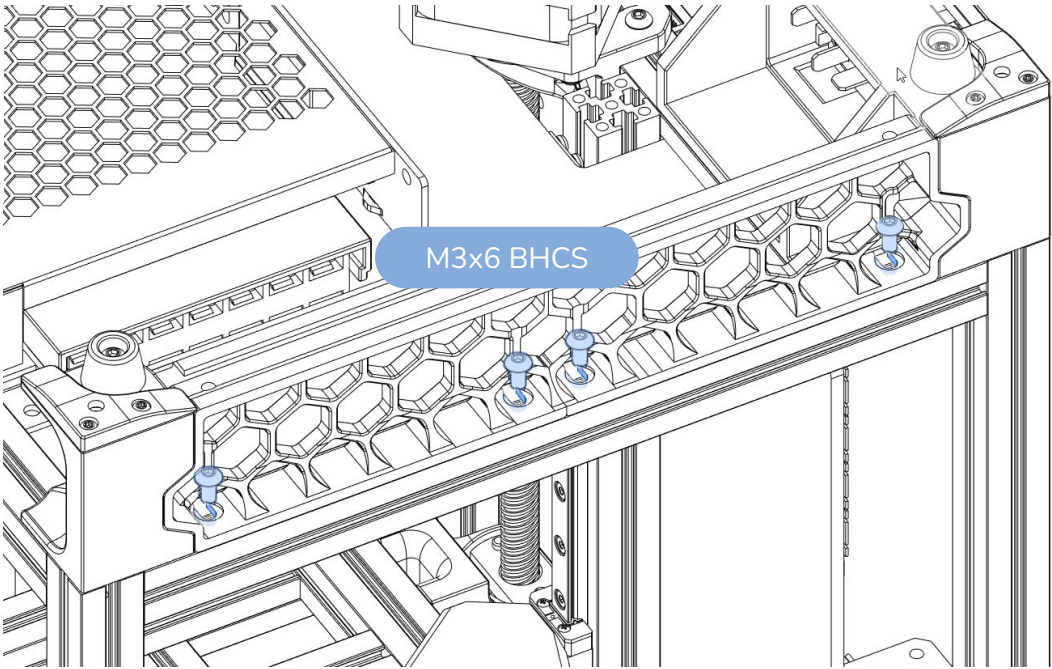
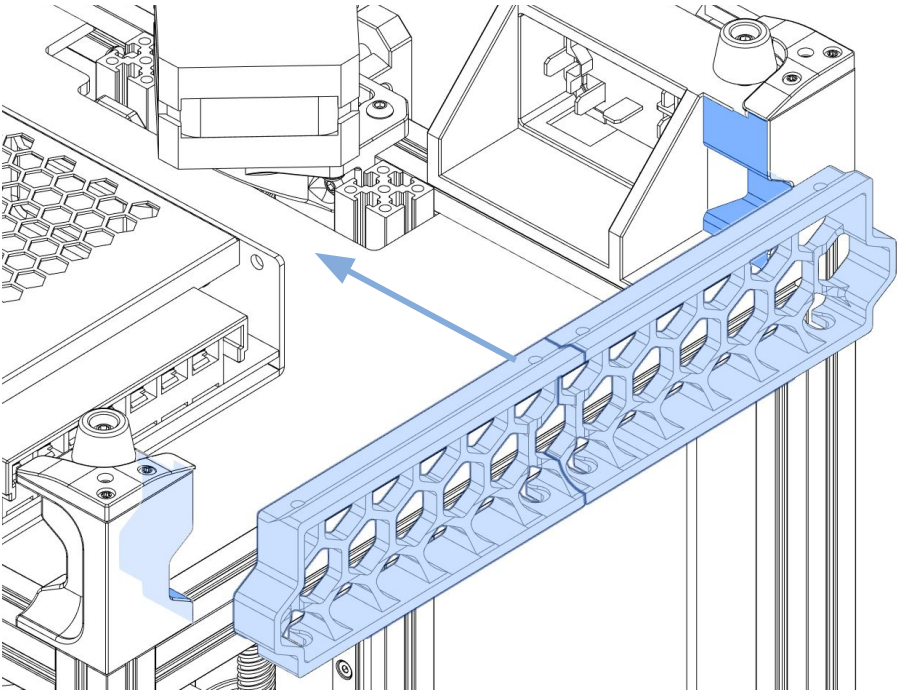

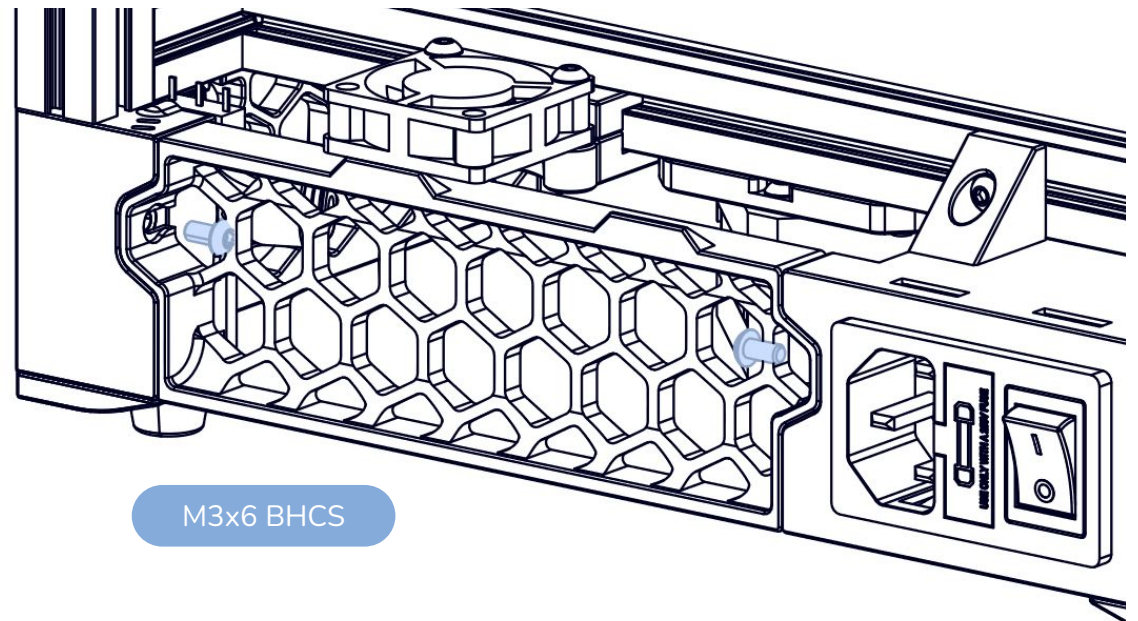
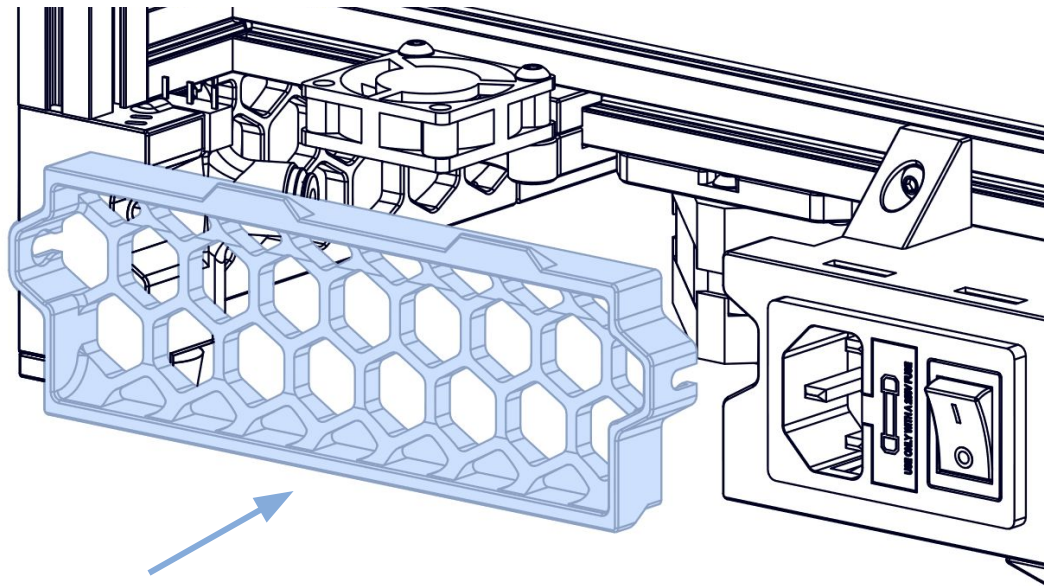

USE A BALL-END DRIVER

Use a 2mm ball-end driver to fasten the screws.

M3x6 BHCS

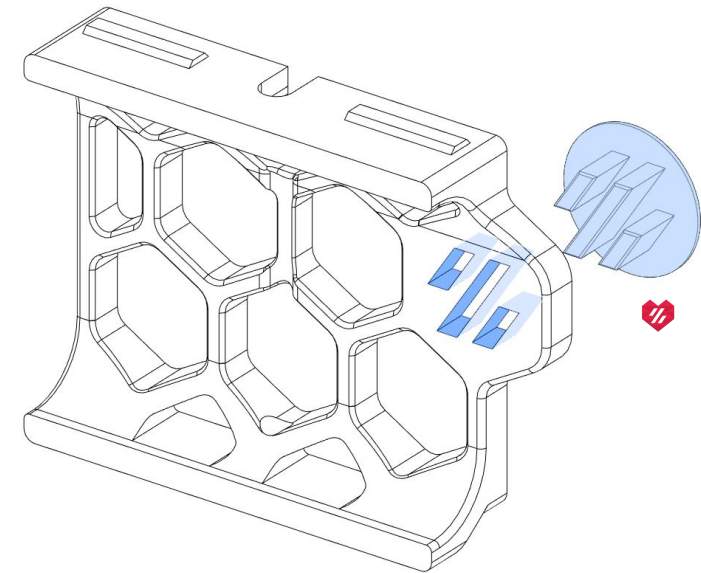
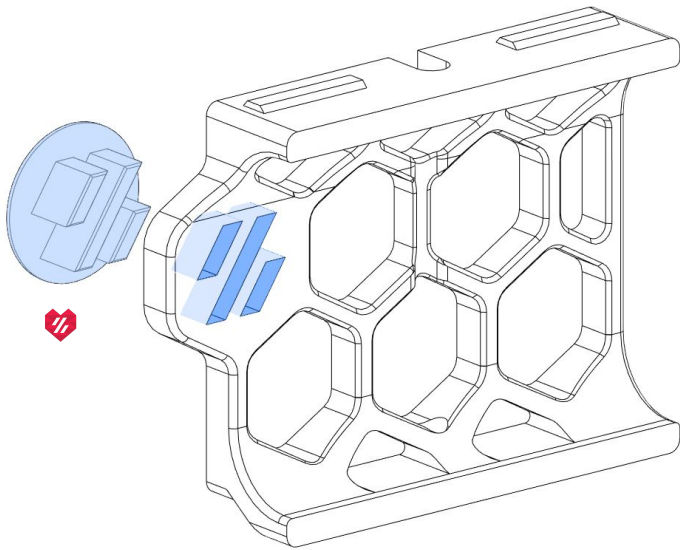

ALL DAPPERED UP

Firmly press the skirt logo accents into the left and right front skirts. If you feel it is necessary to glue them, you may, but it is not a requirement.

SKIRTS - FRONT

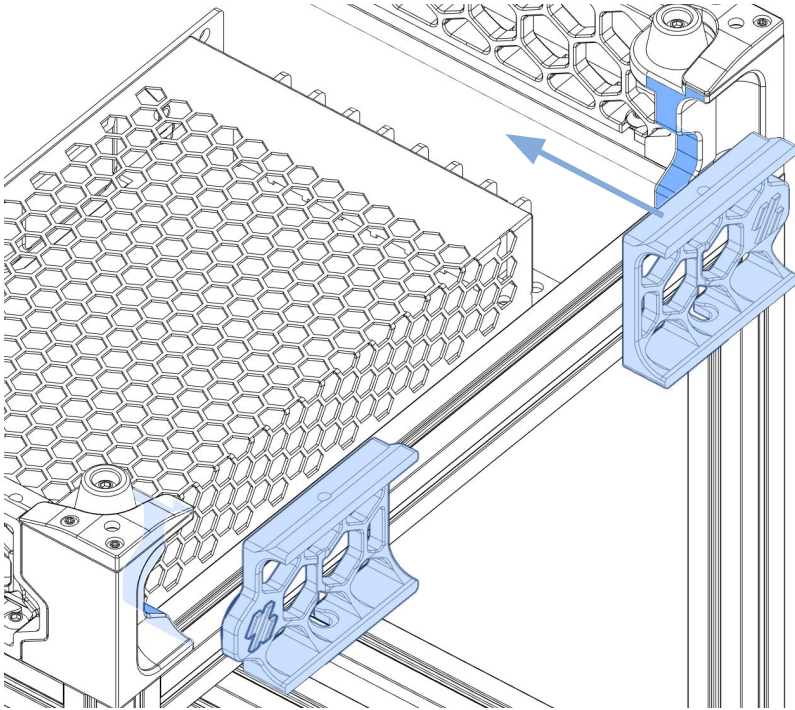

MIND THE GAP

Line up the skirts with the feet, and install them. We will be installing the display in a later step, so leave room for it in the center. If you do not wish to use a display, a blank center skirt piece is available in the release files.

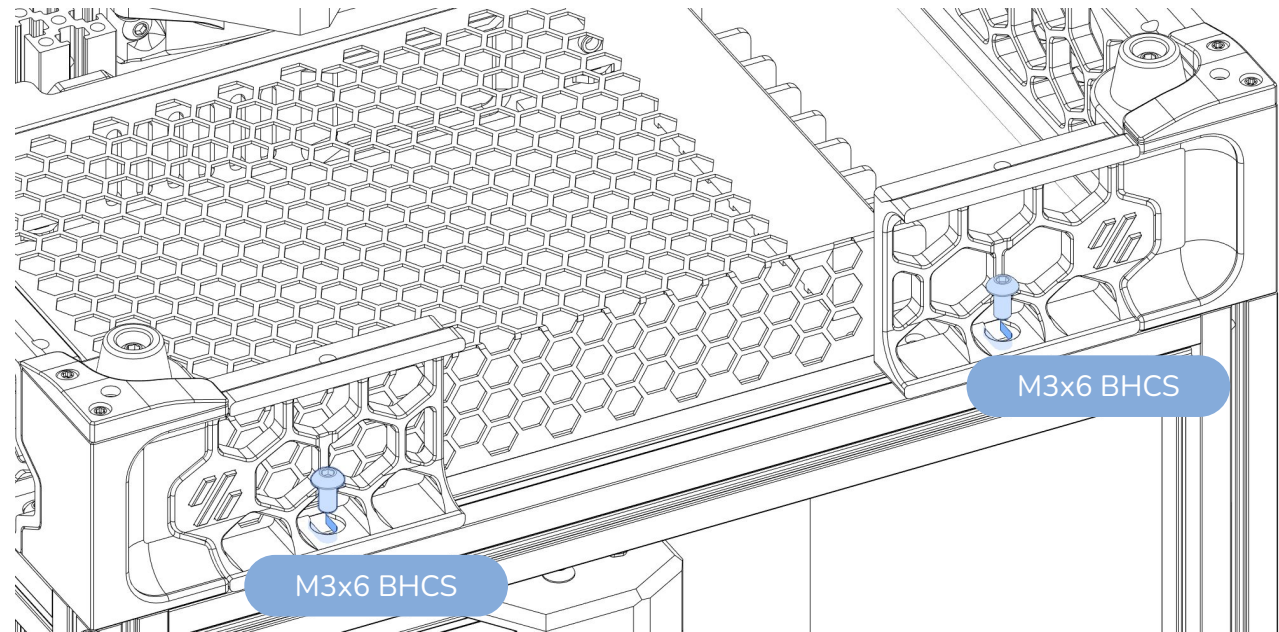

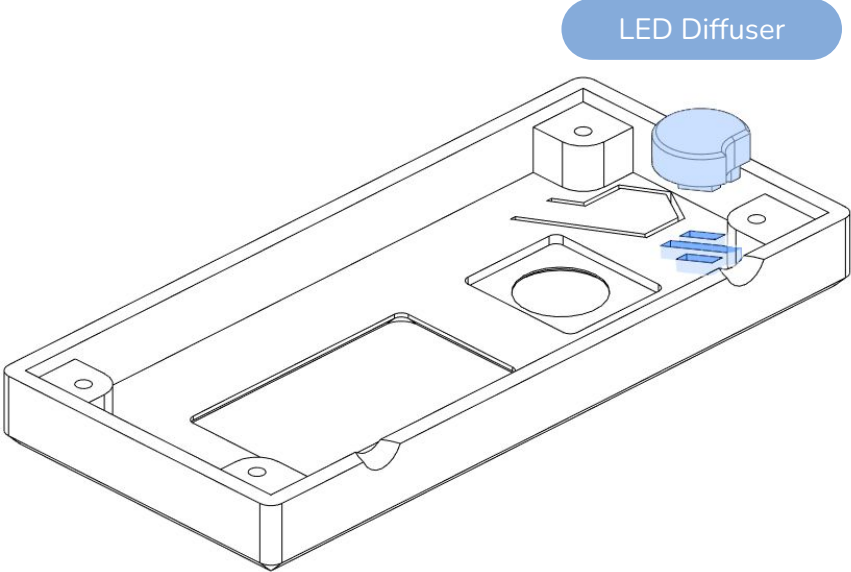

VORON Zero Display PCB

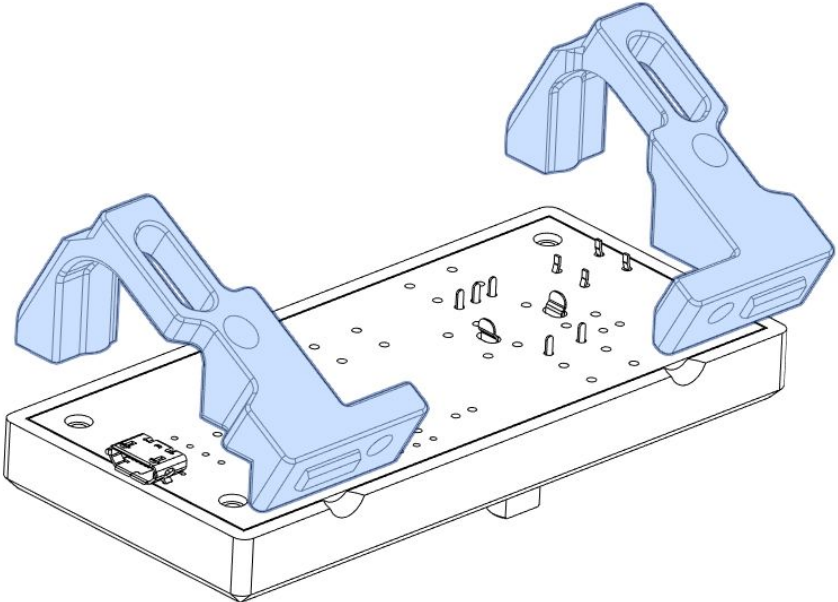
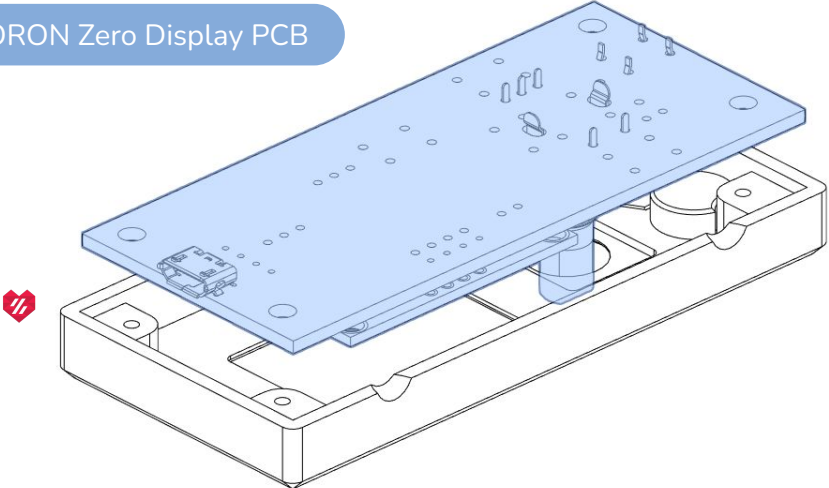

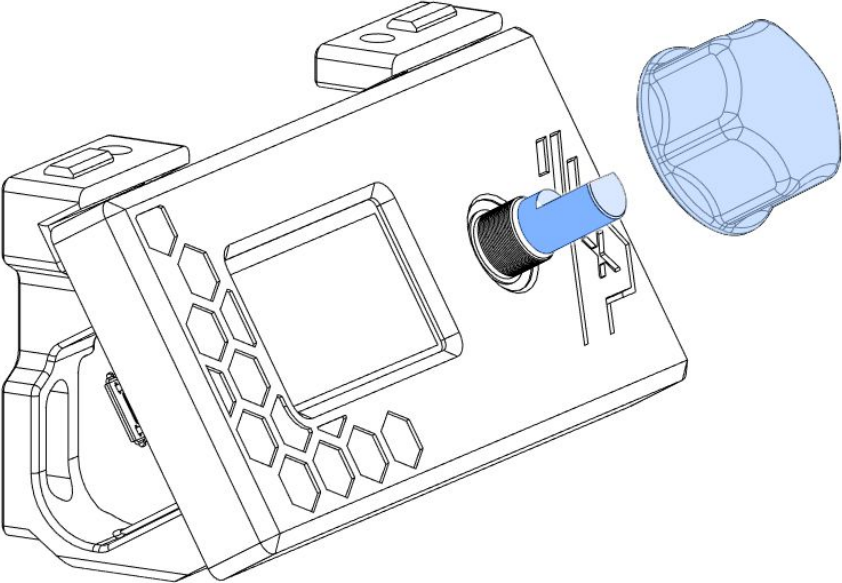
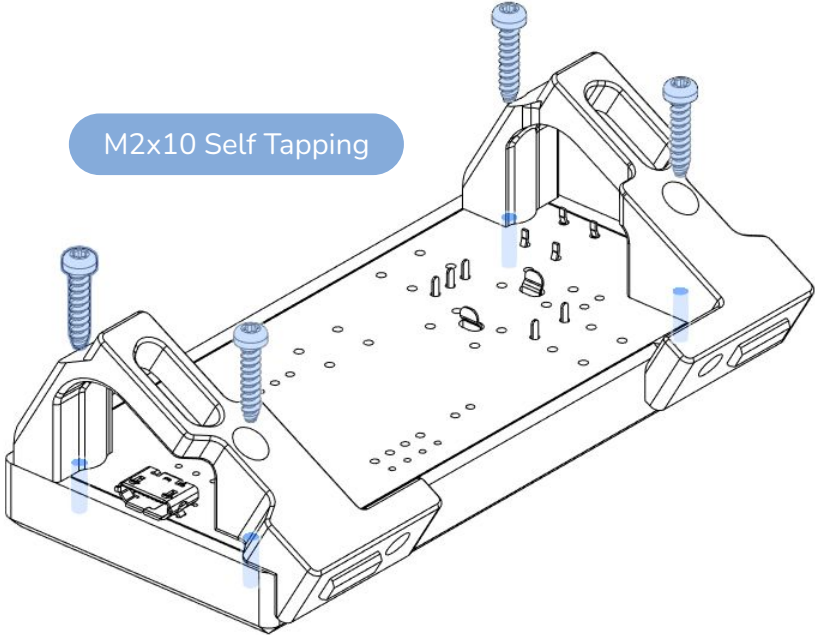

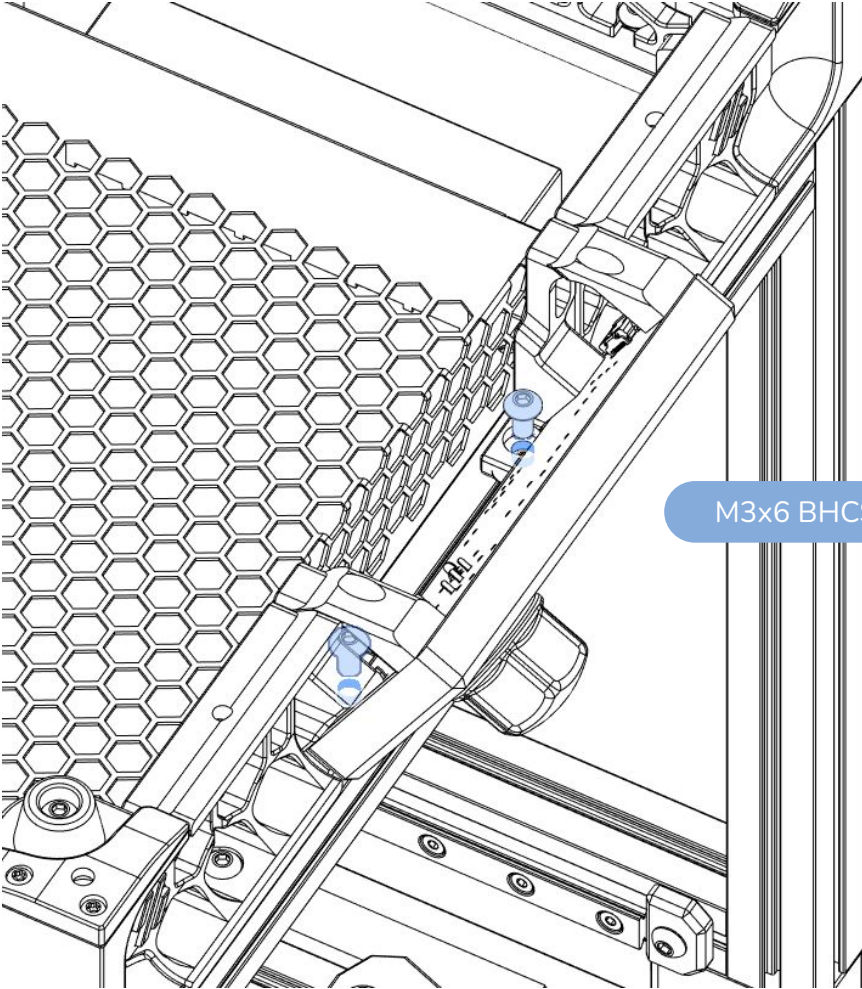
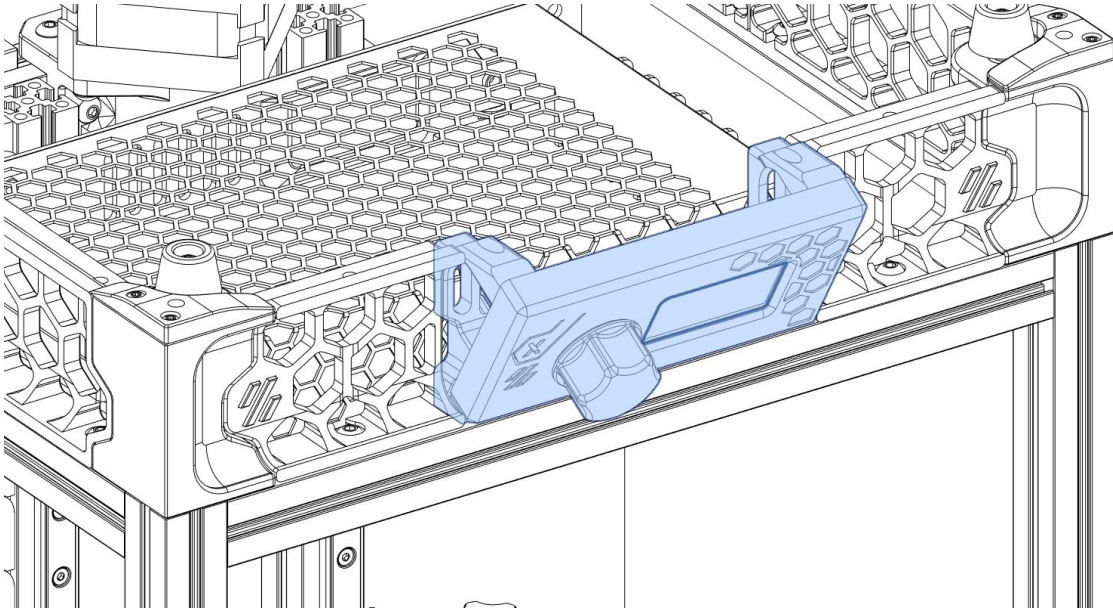

M3x6 BHCS

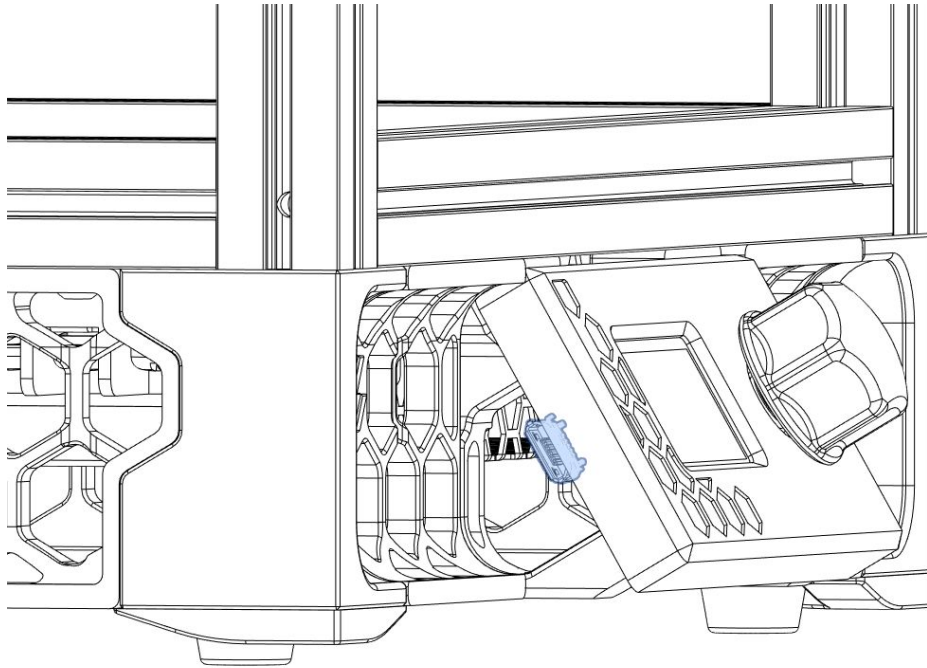

USB TO RASPBERRY PI

The display has a micro USB port on the side or a USB header on the back for connecting to the Raspberry Pi. **These connectors can be fragile**, so pay attention when running this cable.

If you are not using a display, a blank front skirt piece is available in the release files.

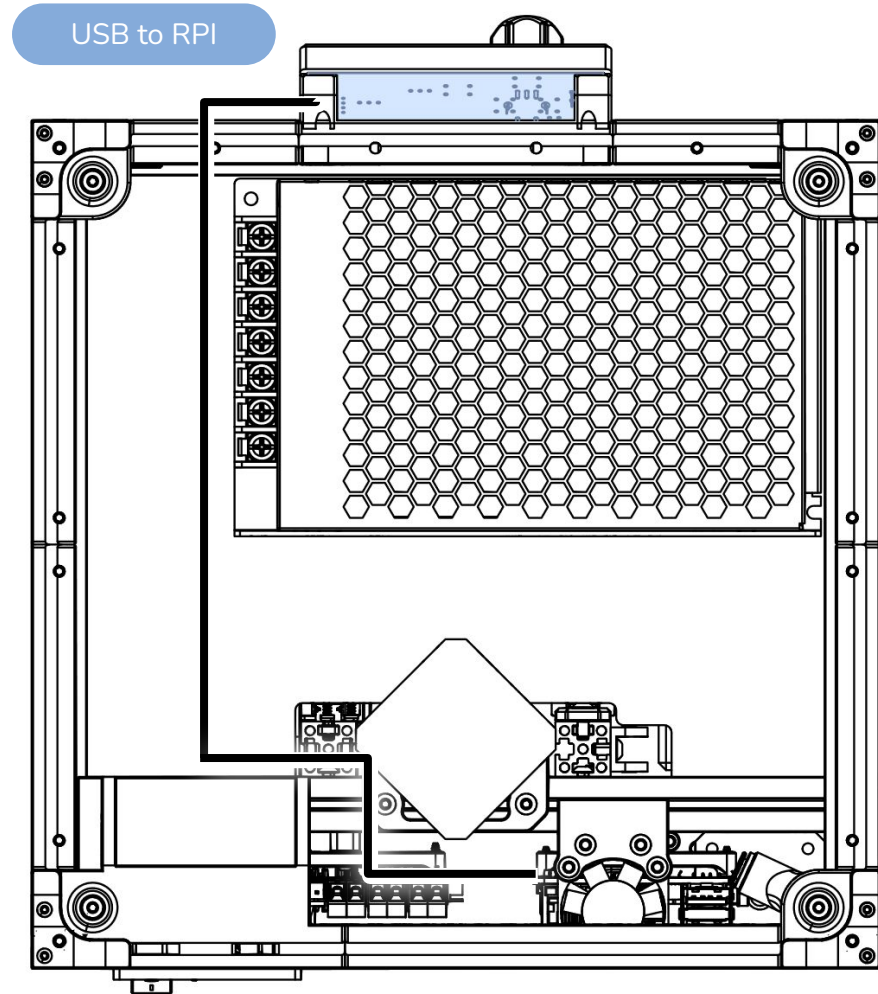

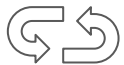
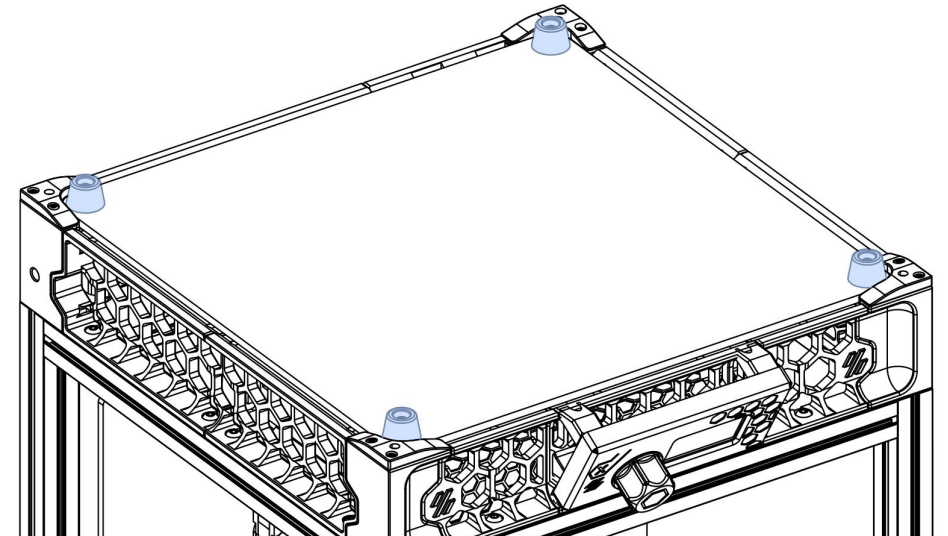
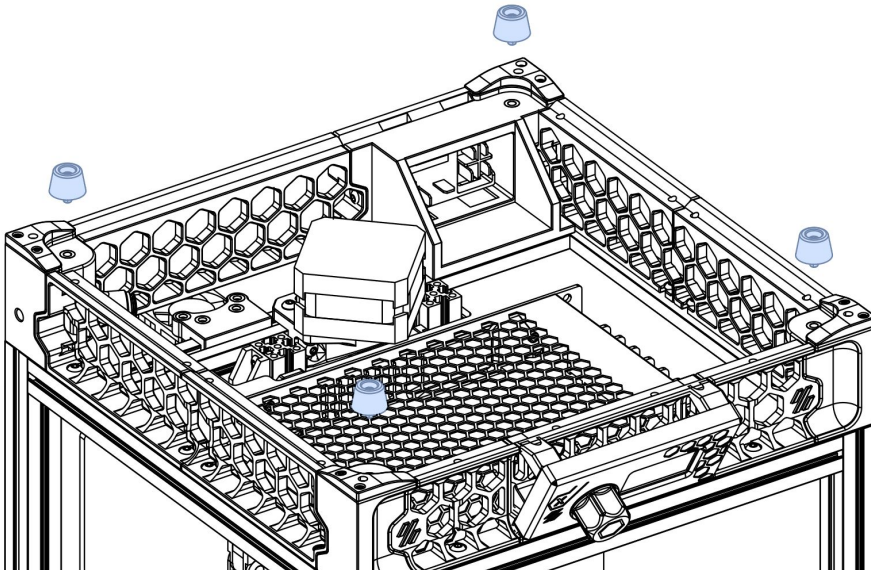

BUT LIEUTENANT DAN... YOU AIN'T GOT NO LEGS!

We need to remove the rubber feet in order to install the bottom panel.

WE CAN REBUILD HIM

Reattach the feet to secure the panel in place. **The 4 hole pattern is not a perfect square** so if the holes don't seem to align try rotating the panel 90 degrees.

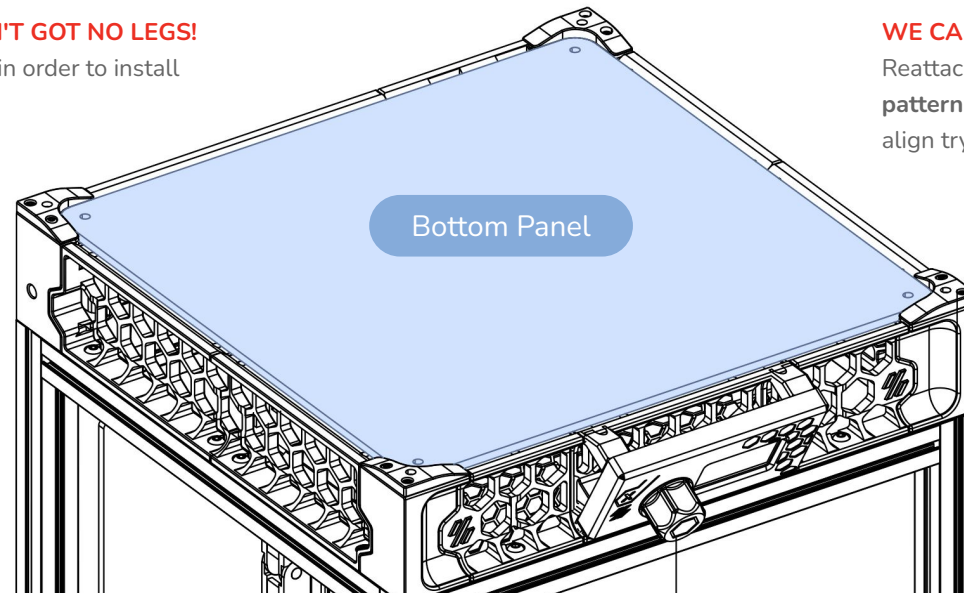

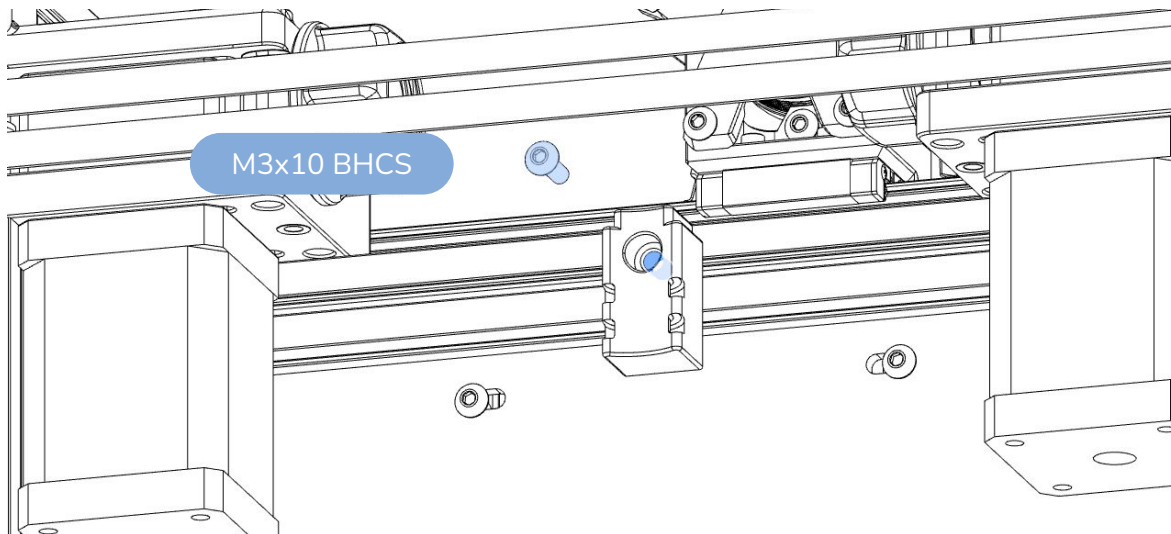
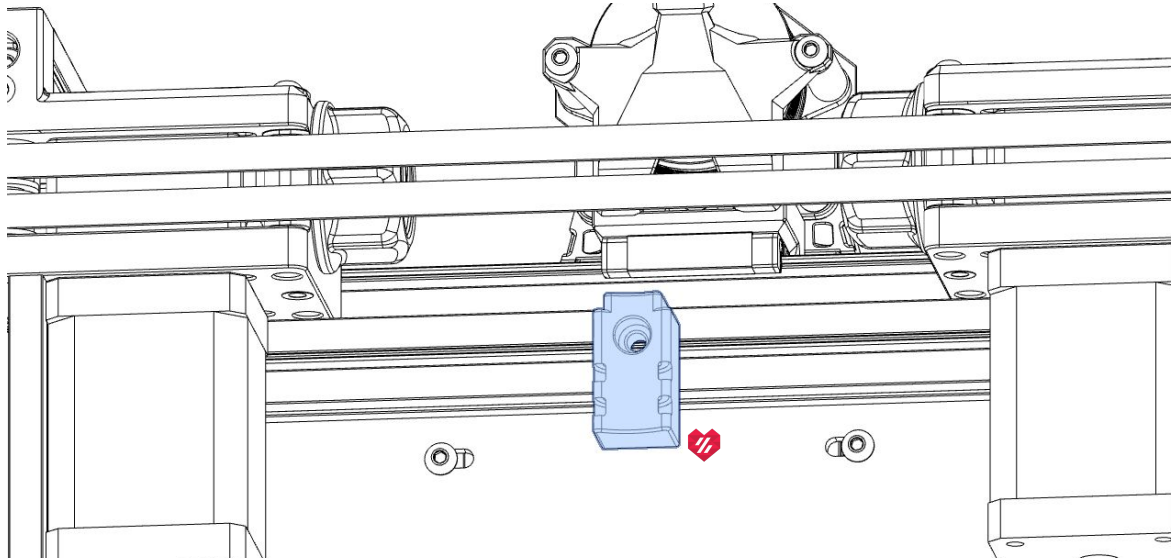

CABLE PASSTHROUGH

Align the strain relief with the cutout in the motor panel. Route the wire bundle and bowden tube through the cutout prior to fastening the panel.

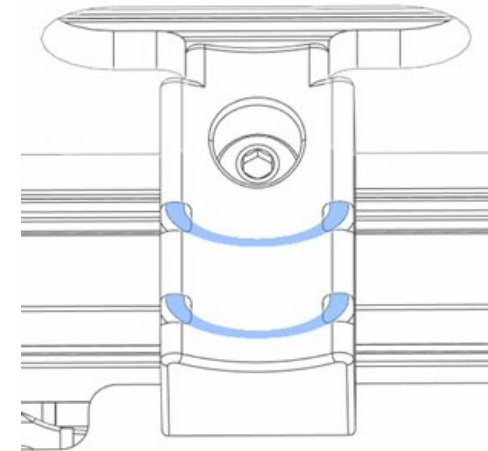

ZIP TIE LOOPS

Secure the wire bundle and bowden tube to the strain relief using small zip ties.

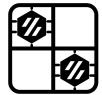

UMBILICAL PCB

If you are using an aftermarket toolhead board it may have a part which replaces this panel with a power distribution board.

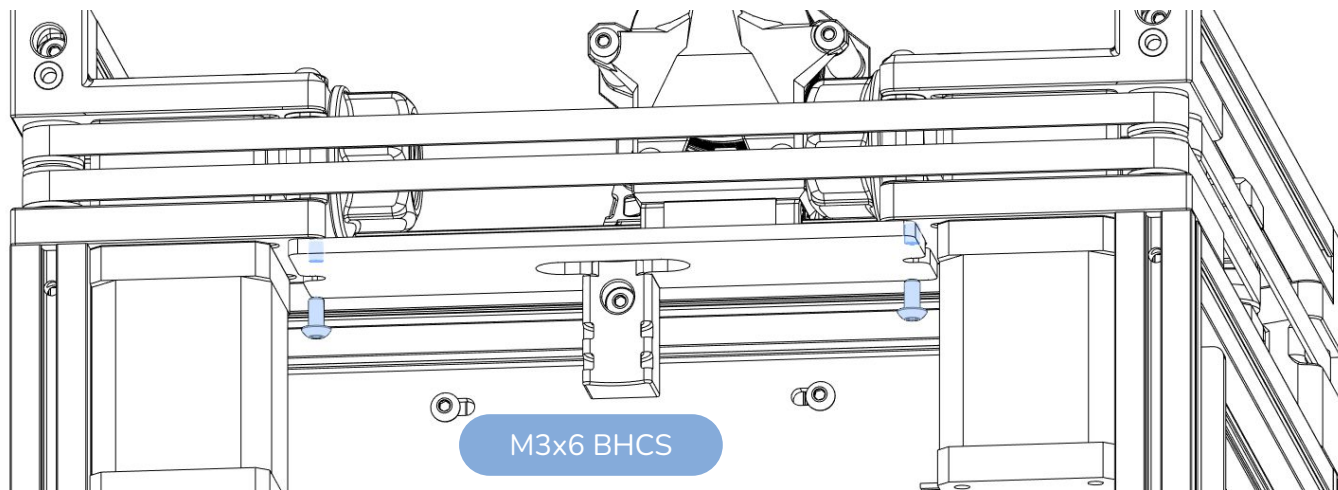
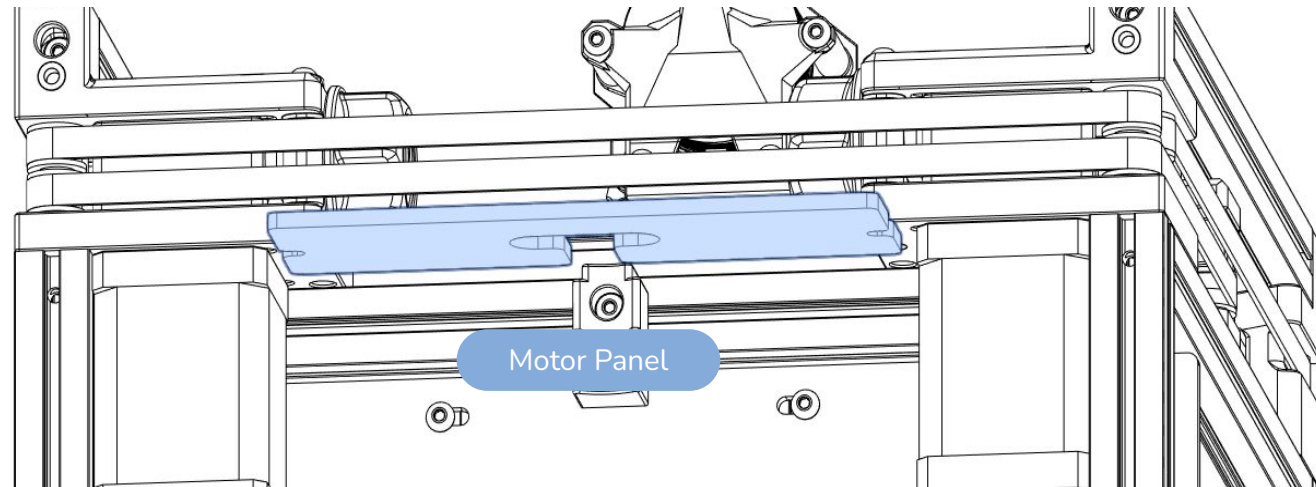

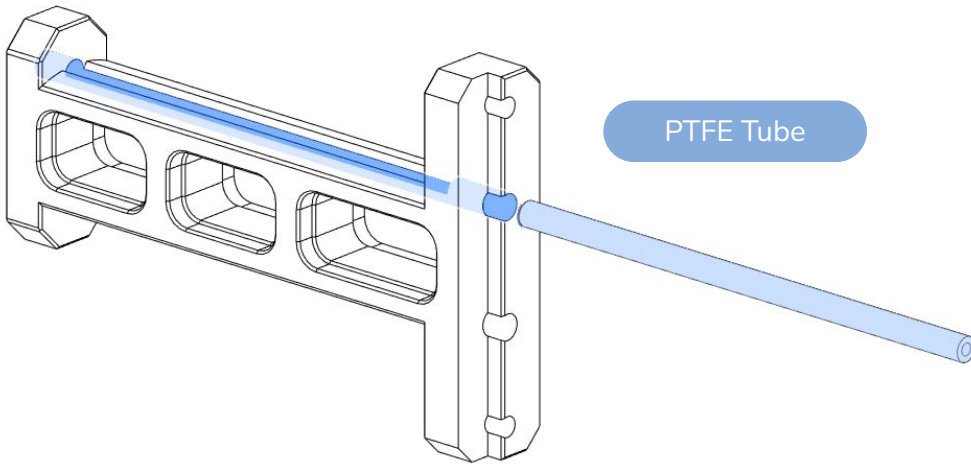

SLIP-N-SLIDE

The PTFE tube is used to reduce the friction between the spool and the holder. Only the top side requires PTFE.

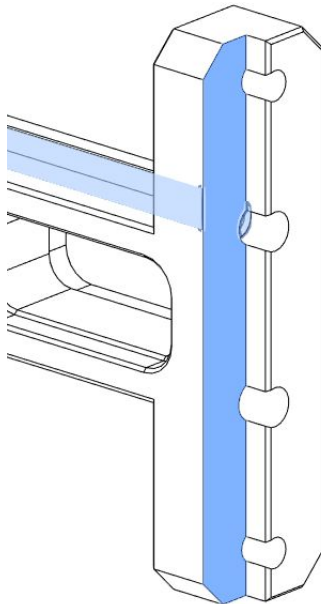

CUT FLUSH

Cut the PTFE tube so that it sits flush with the surface of the part.

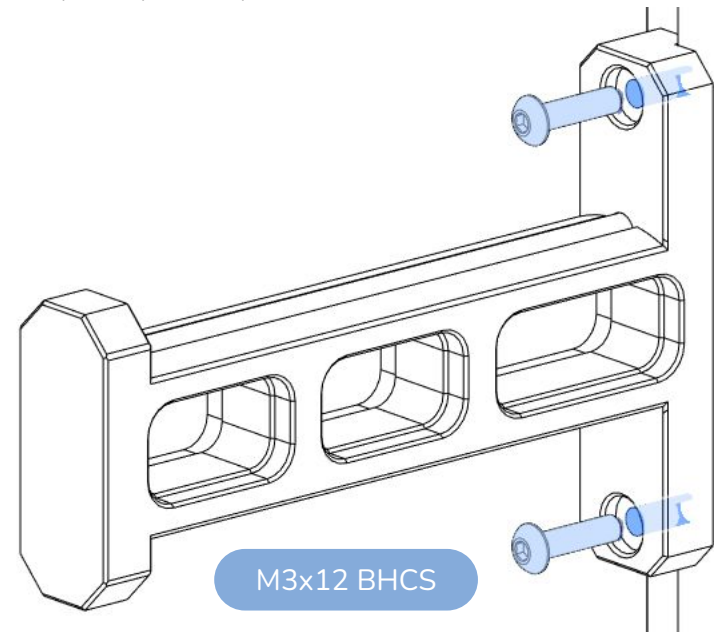

BOWDEN TUBE

WWW.VORONDESIGN.COM

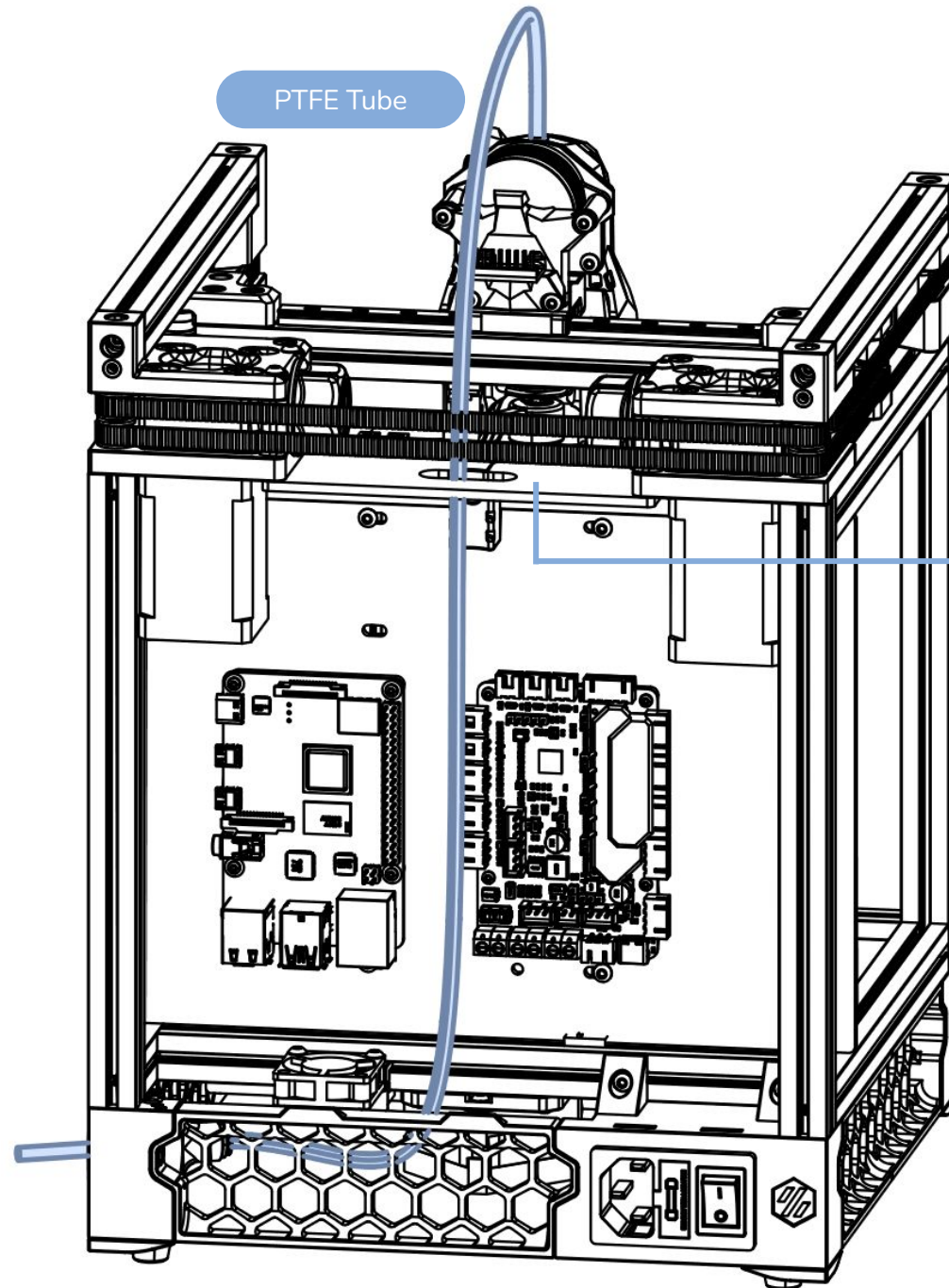

REVERSE BOWDEN FEED TUBE

Route a 3mm ID bowden tube from the rear right foot to the toolhead. If you are using the filament sensor foot you will need to cut one large piece and one small piece as the tube does not pass continuously through the sensor foot in one piece.

ROUGH LENGTH

The length of the Bowden tube from the motor panel to the toolhead should be about 250mm.

PTFE VS FEP

Be sure you are using PTFE tubing (typically a milky white color) and not FEP tubing (typically clear) as non PTFE tubing can cause unnecessary drag on the filament path.

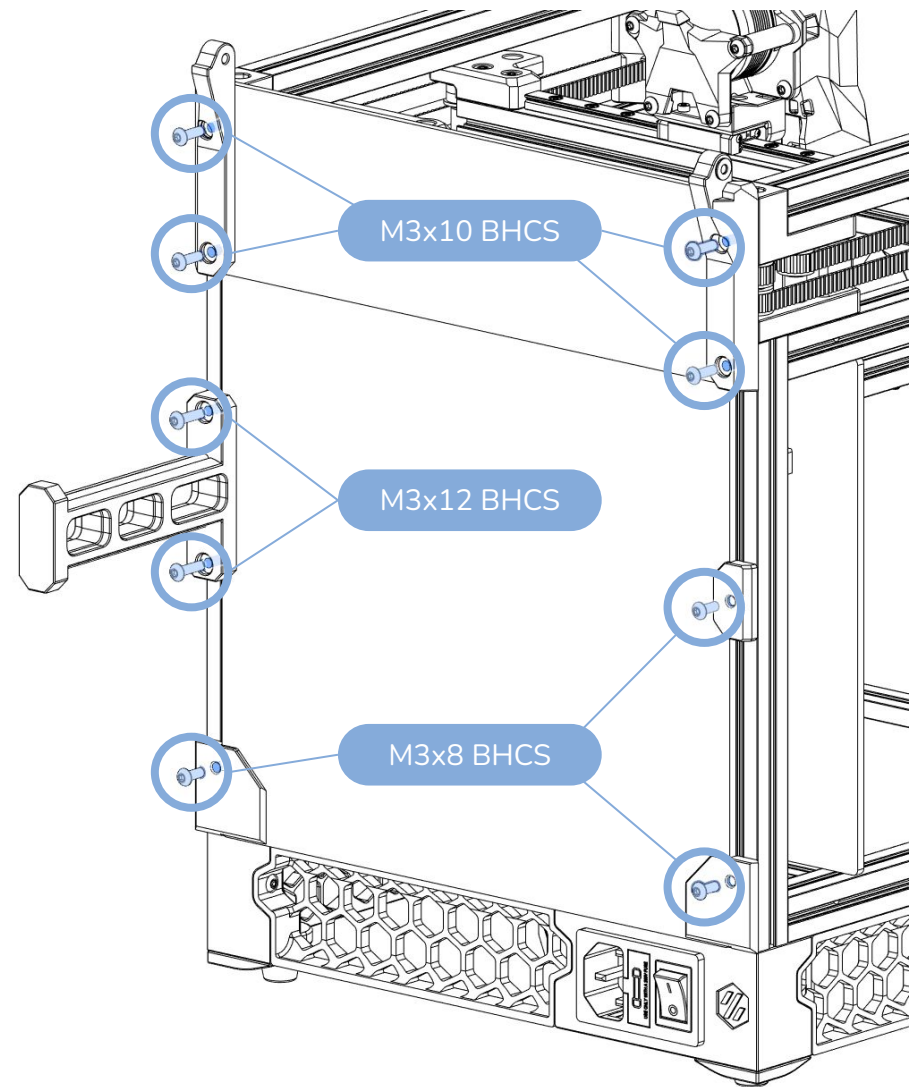
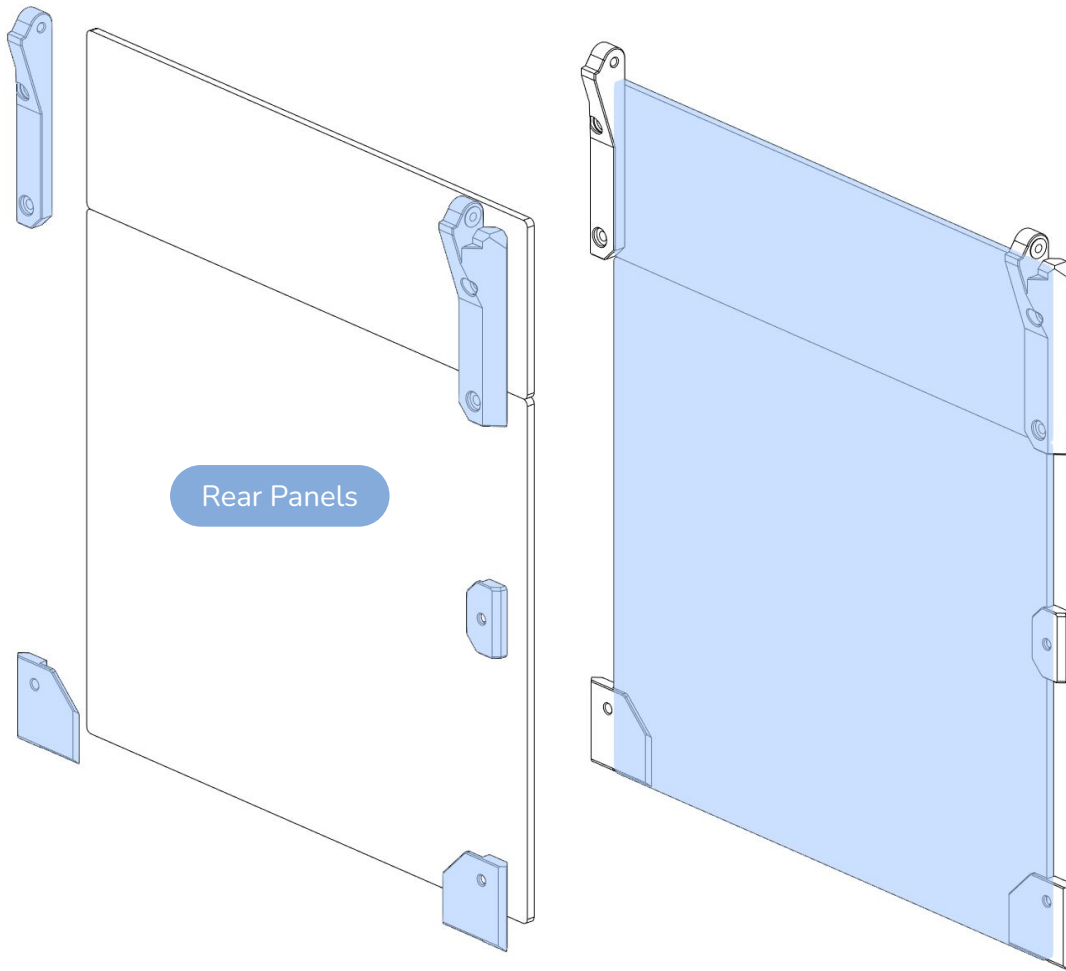

SPLIT REAR PANELS

Place the 3mm panels in place and secure with panel clips. VHB tape is not needed on panel clips. If you want to use VHB on panel clips you will need thicker clips with room for the 1mm thickness that the tape adds.

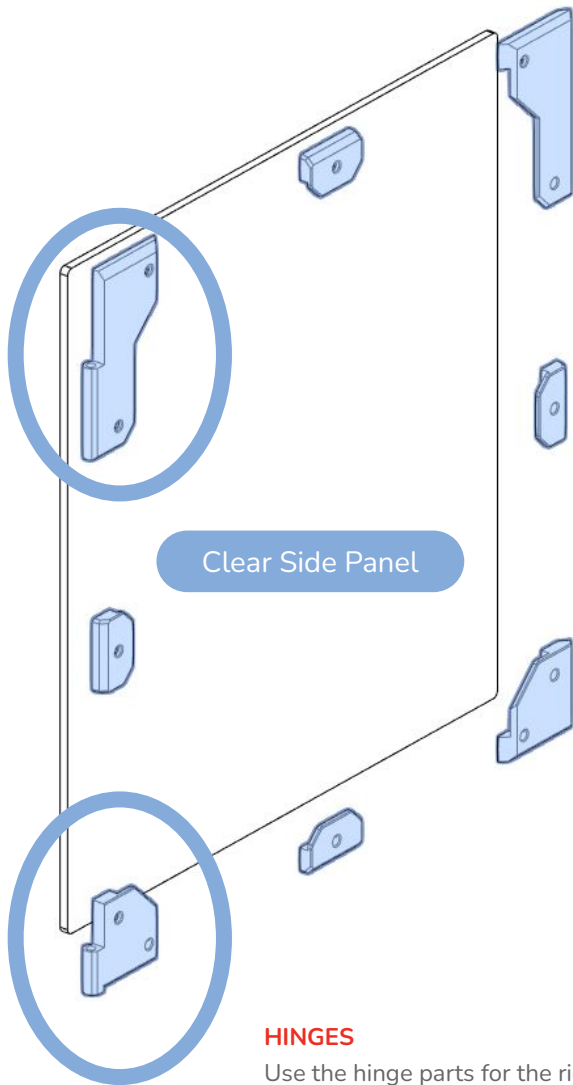

SIDE PANEL

Place the 3mm panel in place and secure with panel clips. VHB tape is not needed on panel clips.

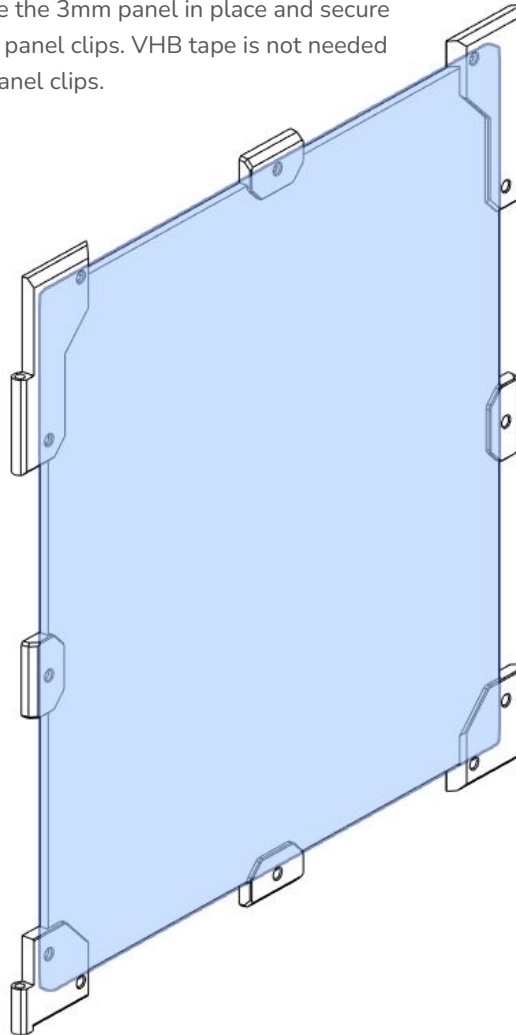

HINGES

Use the hinge parts for the right hand side panel. This is one of the two clear ones that is shorter than the front door.

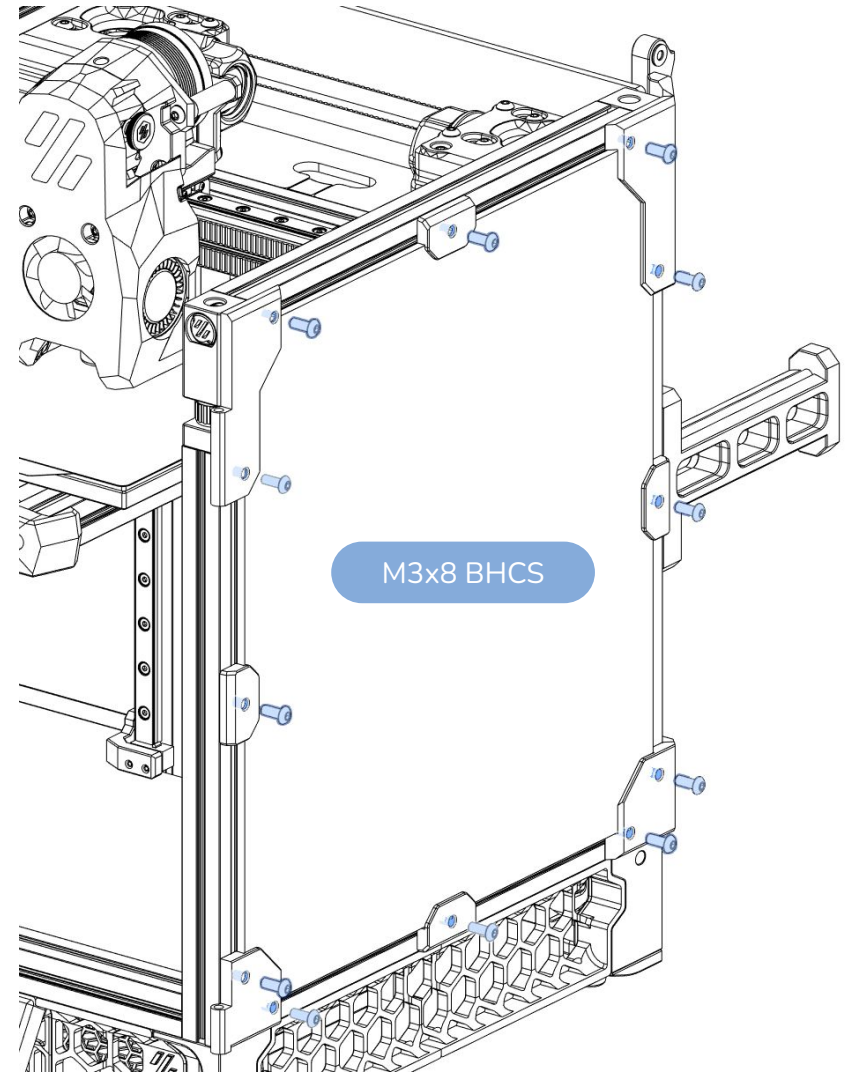

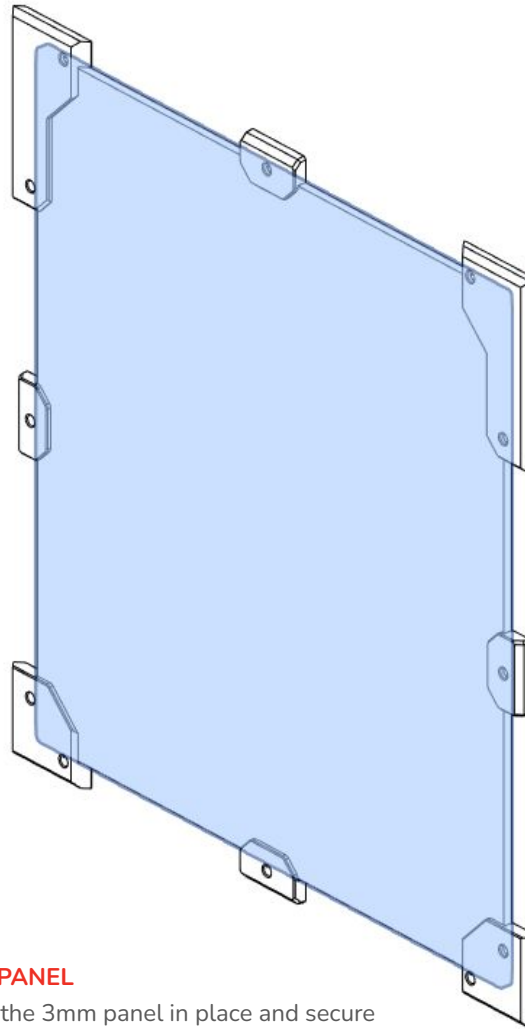
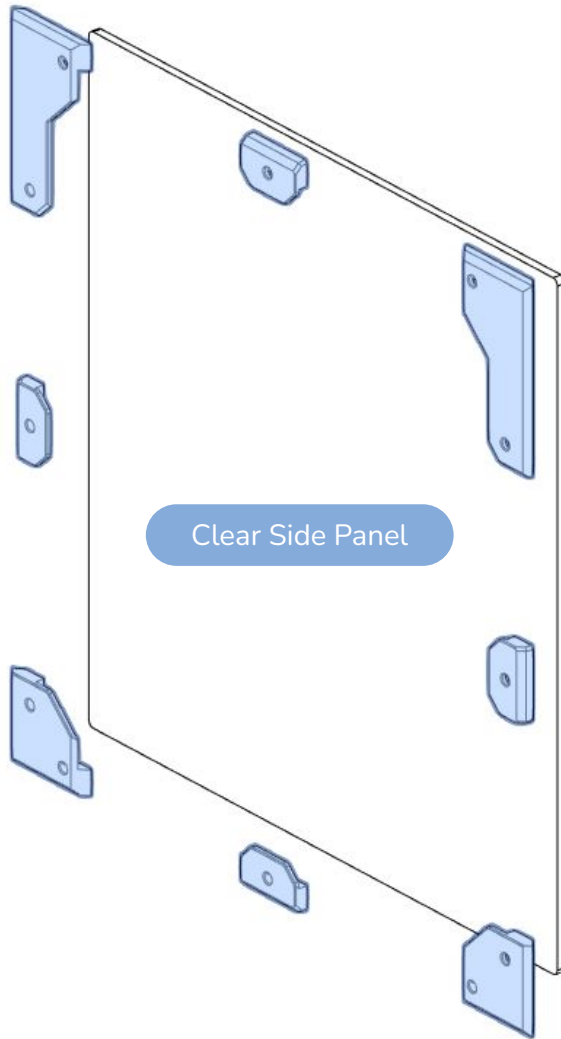

SIDE PANEL

Place the 3mm panel in place and secure with panel clips. VHB tape is not needed on panel clips.

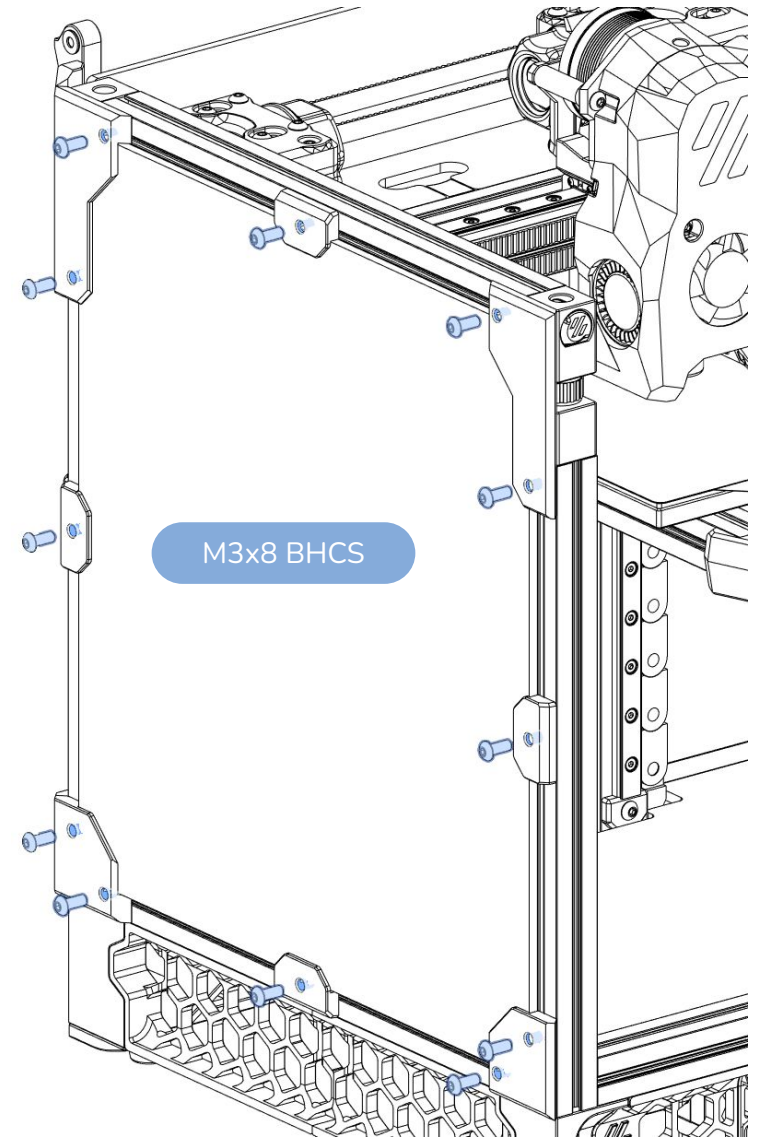

3x6 Magnet

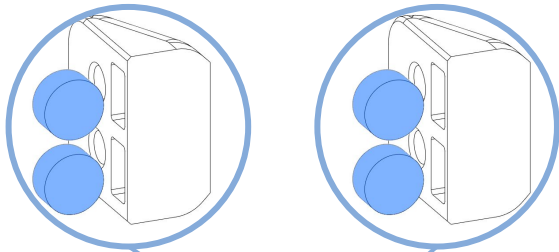

USE SUPERGLUE

You can use a drop of superglue to fix the magnets in place if needed.

MIND THE MAGNET POLARITY

To properly function, the magnets in the latch must attract the magnets in the handle.

Install all magnets in the latch with the same polarity and test the handle before gluing the magnets.

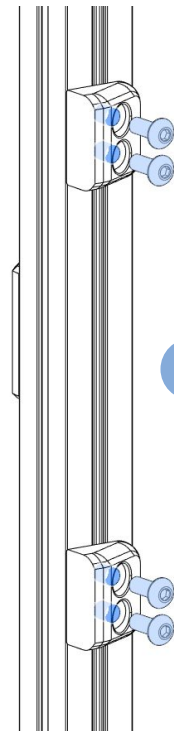
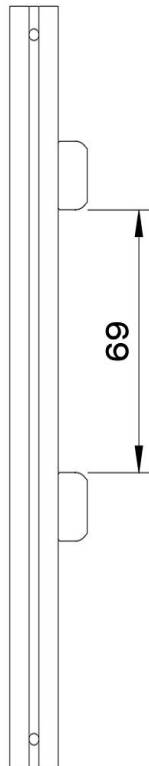

M3x8 BHCS

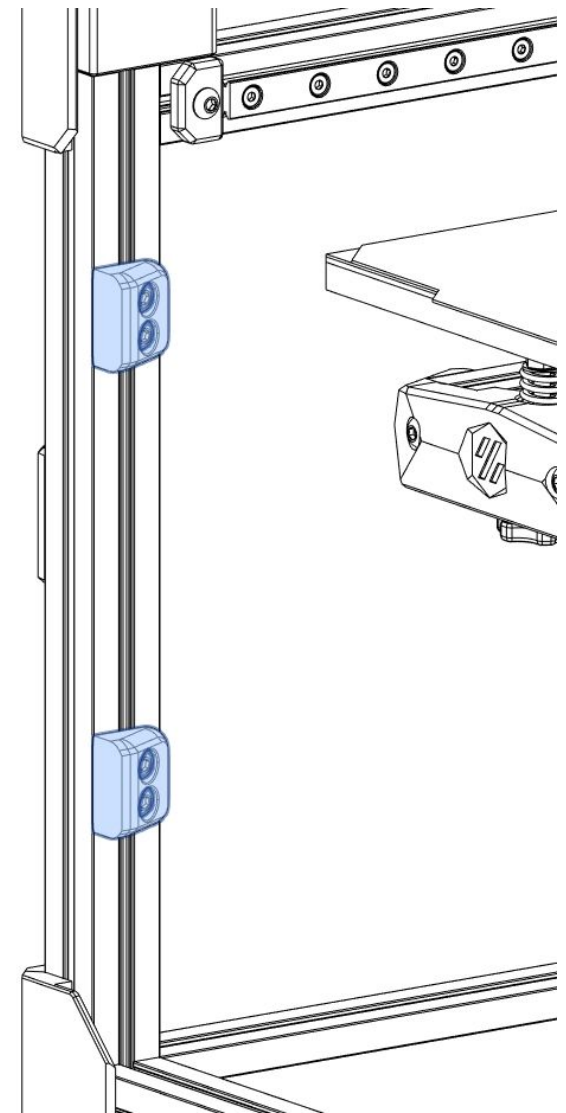

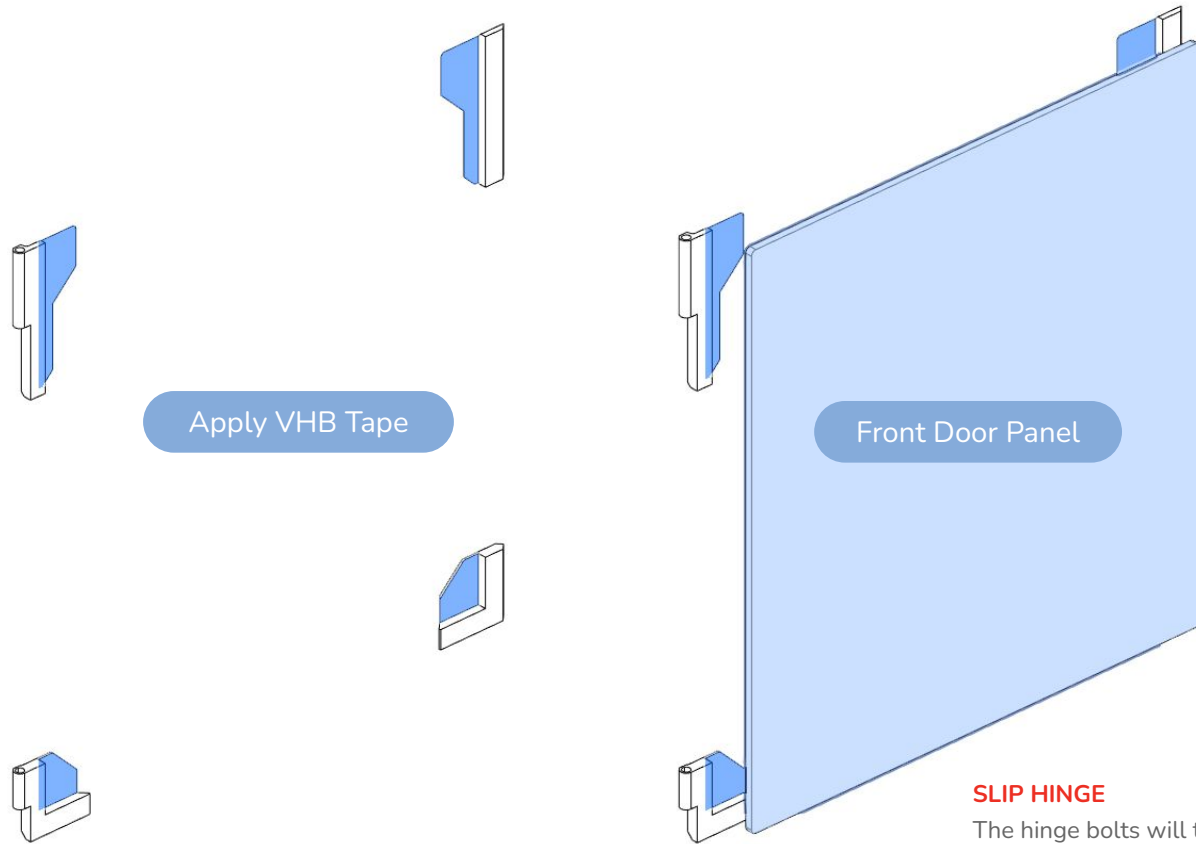

SLIP HINGE

The hinge bolts will thread into plastic on the lower hinge pieces. You should be able to remove the door by sliding it up off of the bolts.

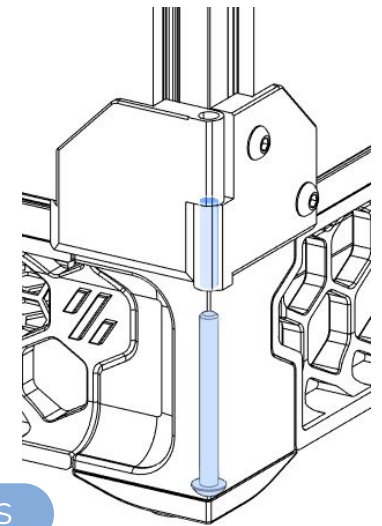
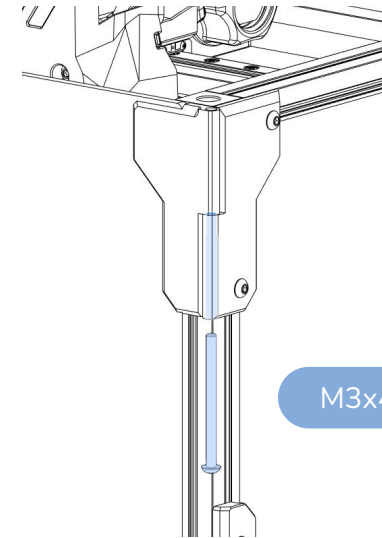



MIND THE MAGNET POLARITY

To properly function, the magnets in the latch must attract the magnets in the handle.

Install all magnets in the latch with the same polarity and test the handle before glueing the magnets.

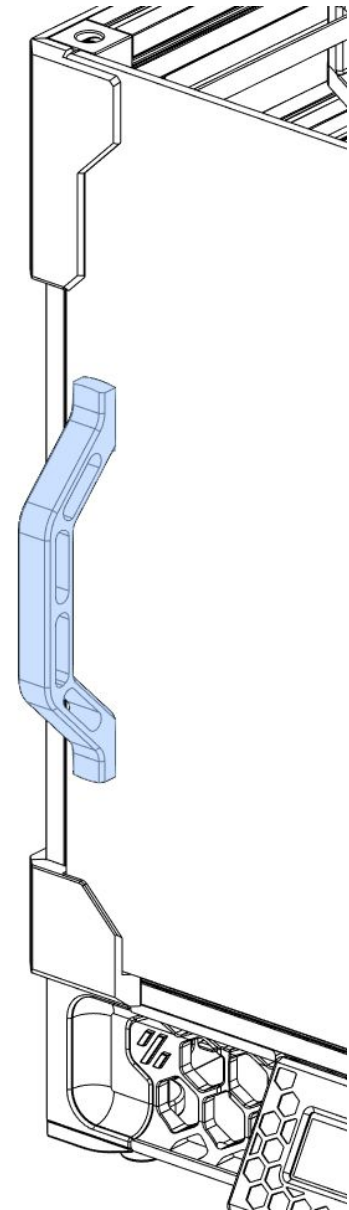
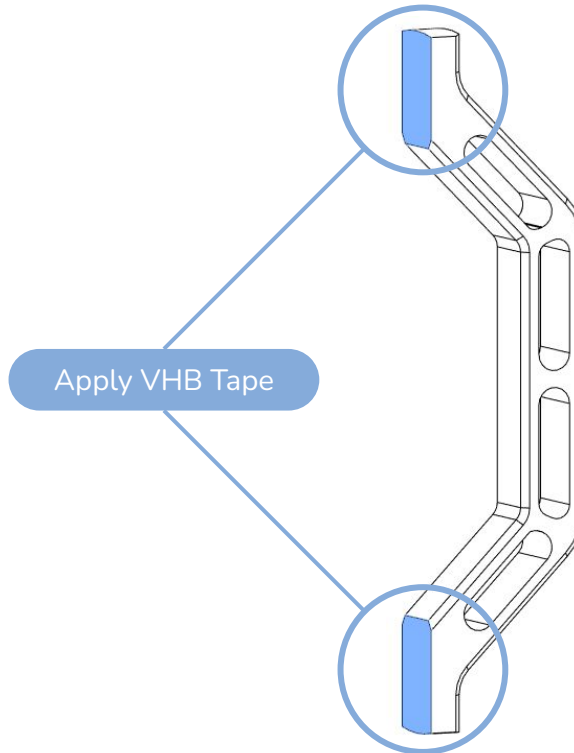
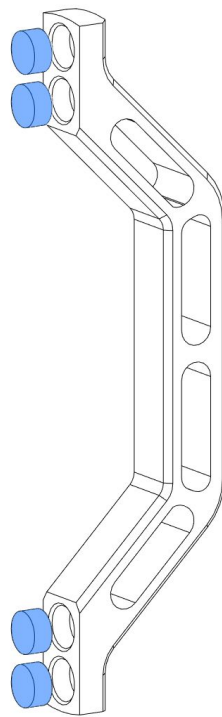





A BOX OF SCRAPS!

You should have 8 extrusions left at this point.

"B EXTRUSION"

Qty 4

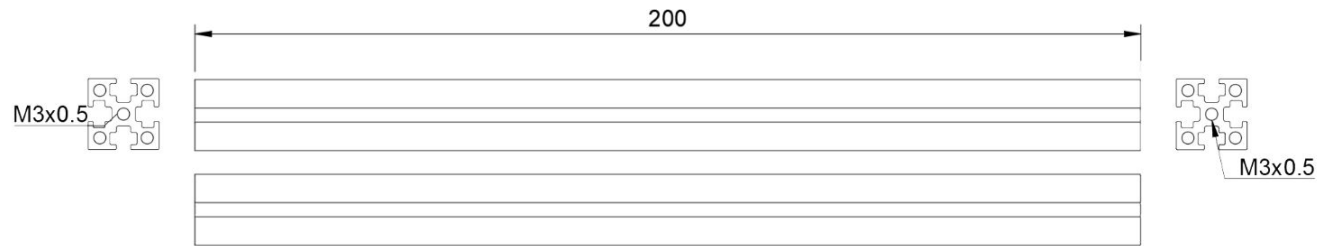

"J EXTRUSION"

Qty 4

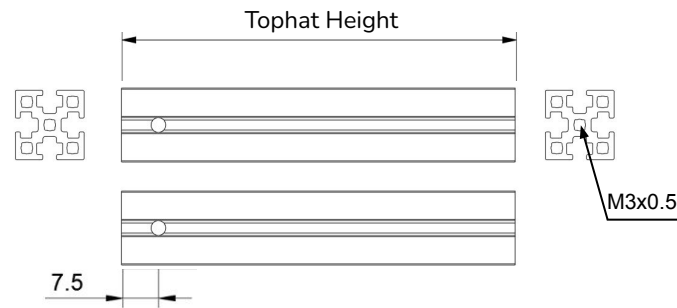

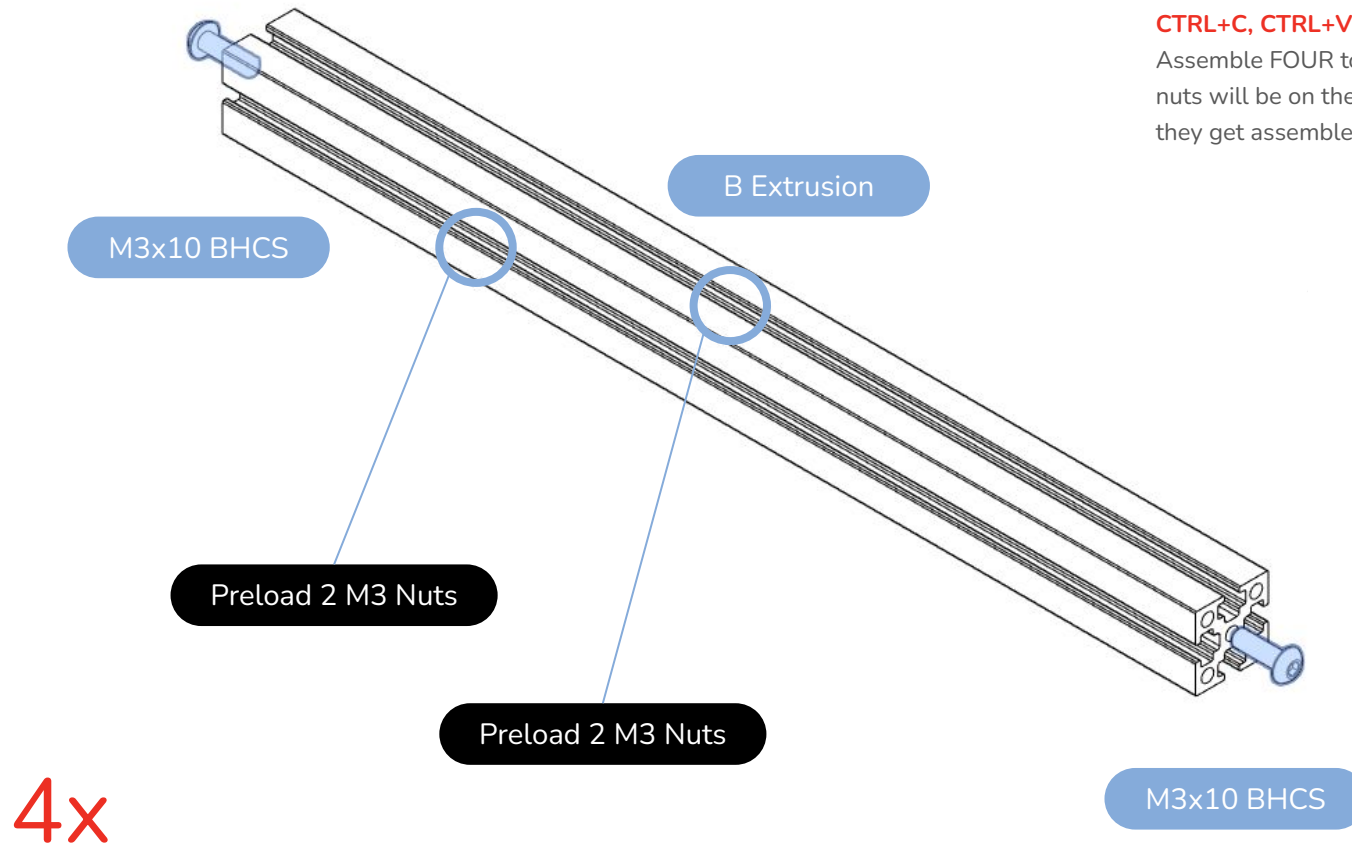

CTRL+C, CTRL+V

Assemble FOUR total of this component. The preloaded nuts will be on the top side and the sides facing out when they get assembled.

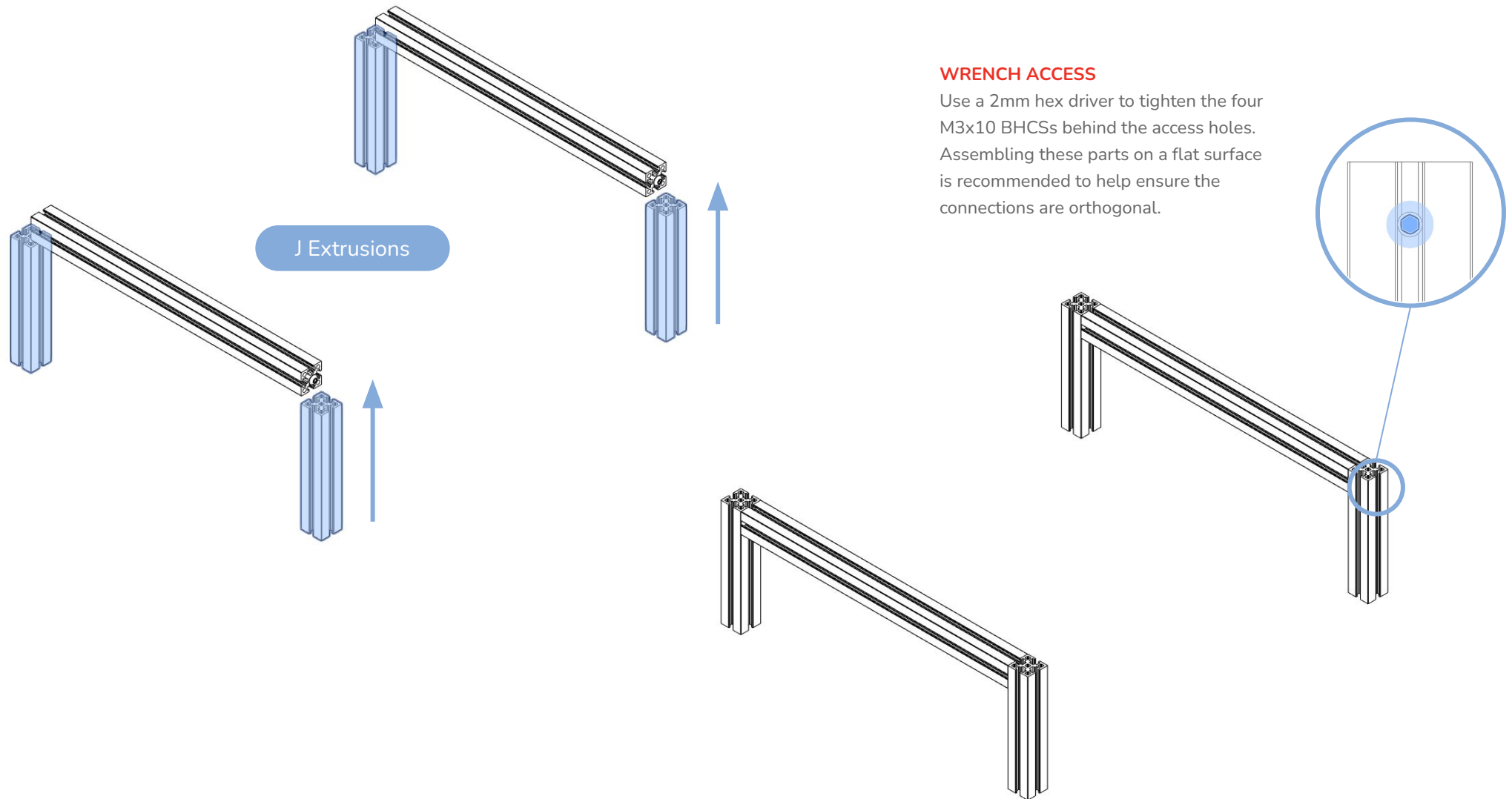

WRENCH ACCESS

Use a 2mm hex driver to tighten the four M3x10 BHCSs behind the access holes. Assembling these parts on a flat surface is recommended to help ensure the connections are orthogonal.

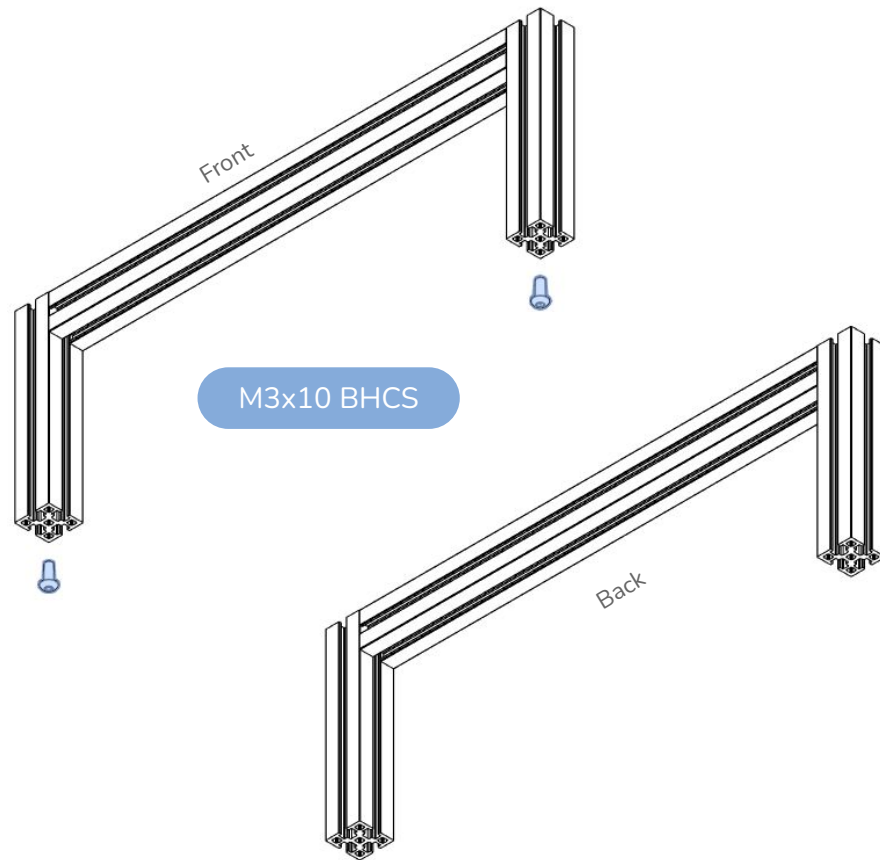

FRONT/REAR FRAME

The front of the tophat will have the two M3x10mm BHCS in the bottom of the "J Extrusions" for locking to the printer frame.

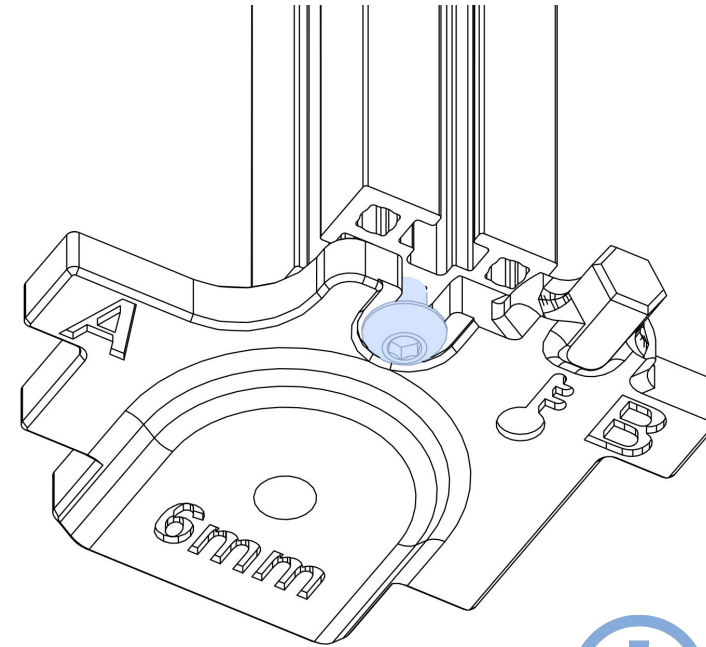

CAM LOCK FUNCTION

In order for the hinged tophat to lock correctly, these two screws need to be fixed at **5mm**. Use thread locker to keep them in place.

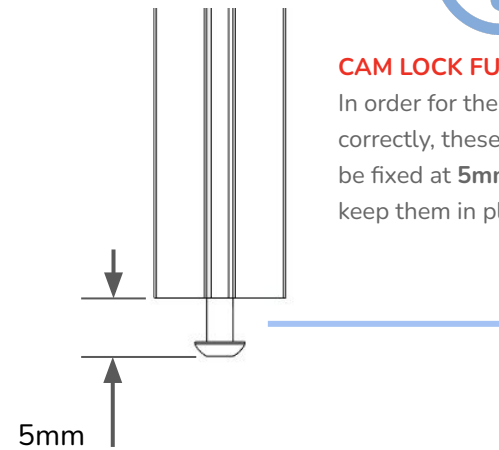

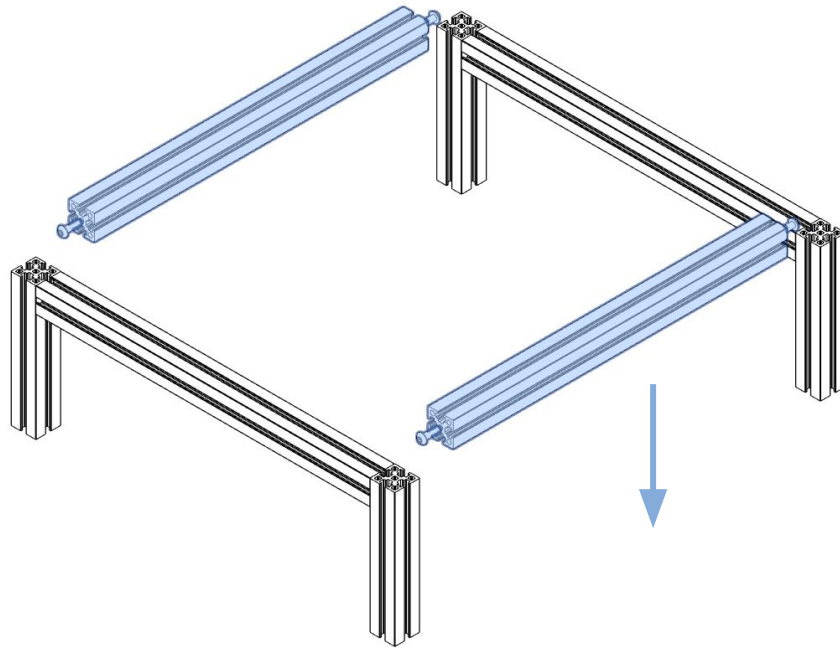

WRENCH ACCESS

Use a 2mm hex drive to tighten the four M3x10 screws behind the access holes to complete the tophat frame. Using a flat surface to ensure orthogonal connections is recommended.

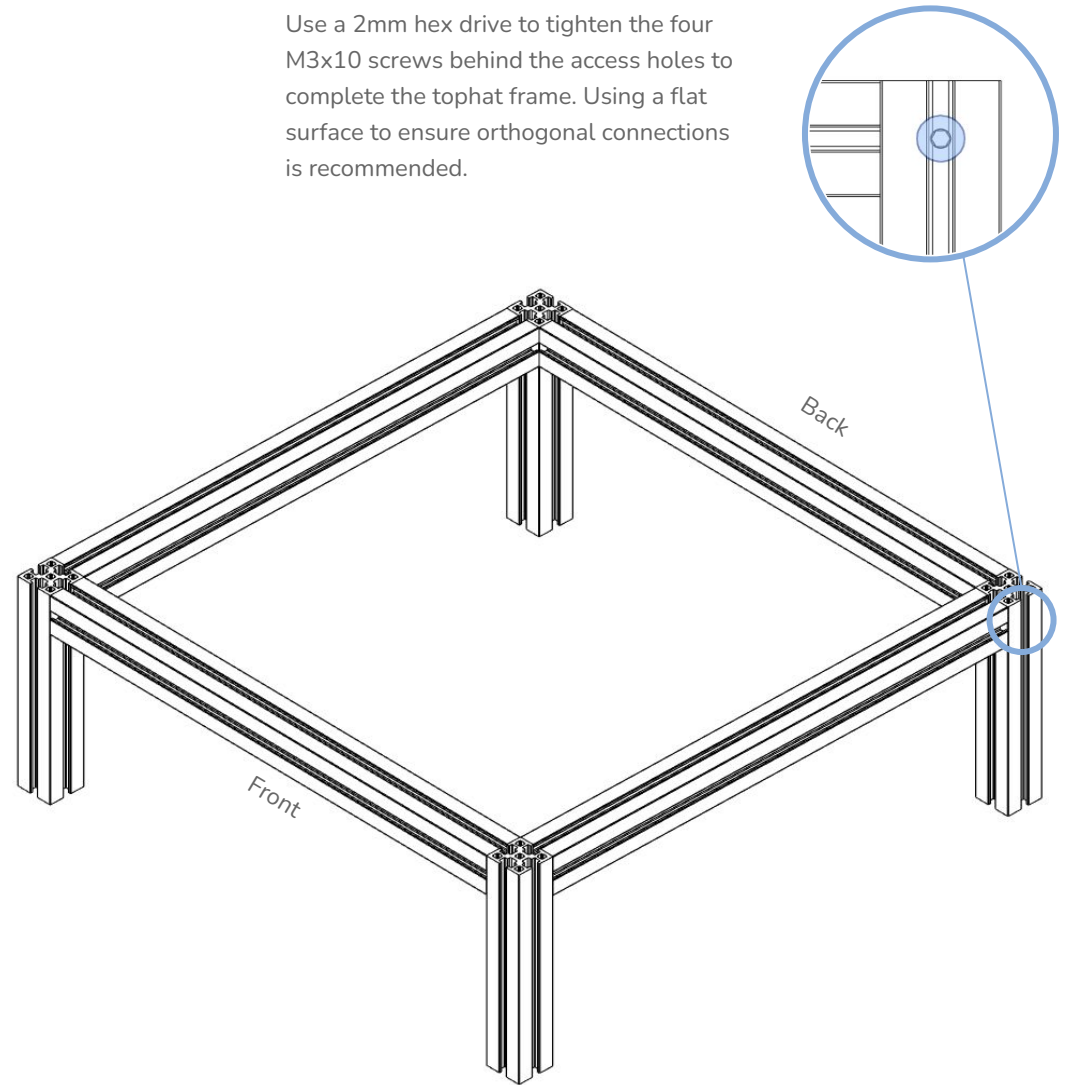

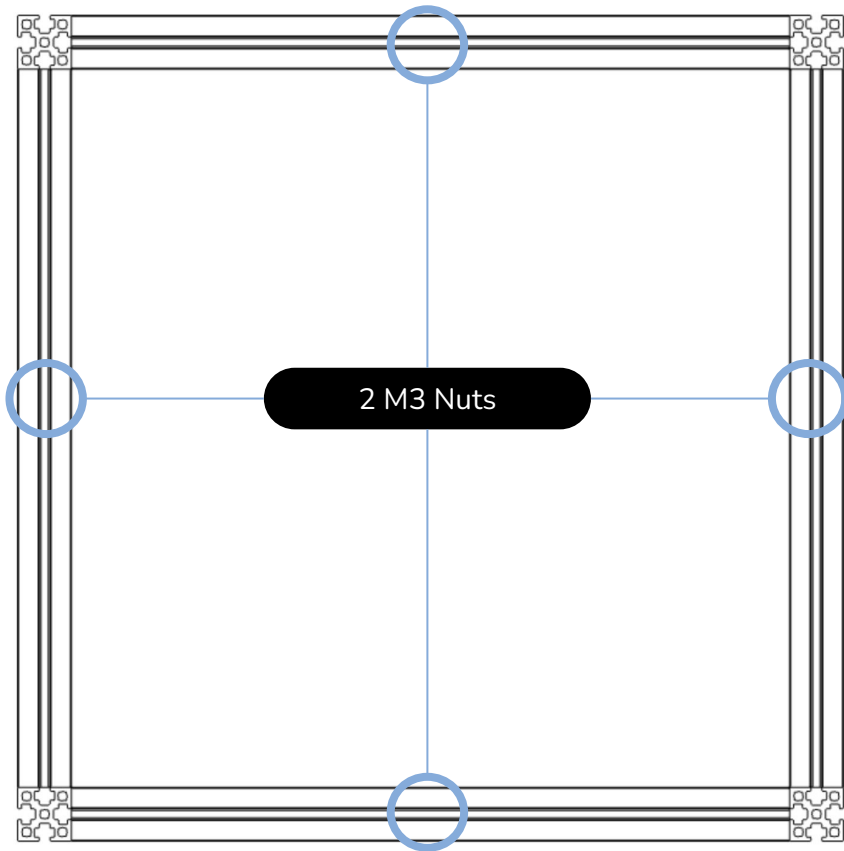

CHECK YOUR WORK

Verify you have preloaded the appropriate M3 Nuts prior to moving to the next step.

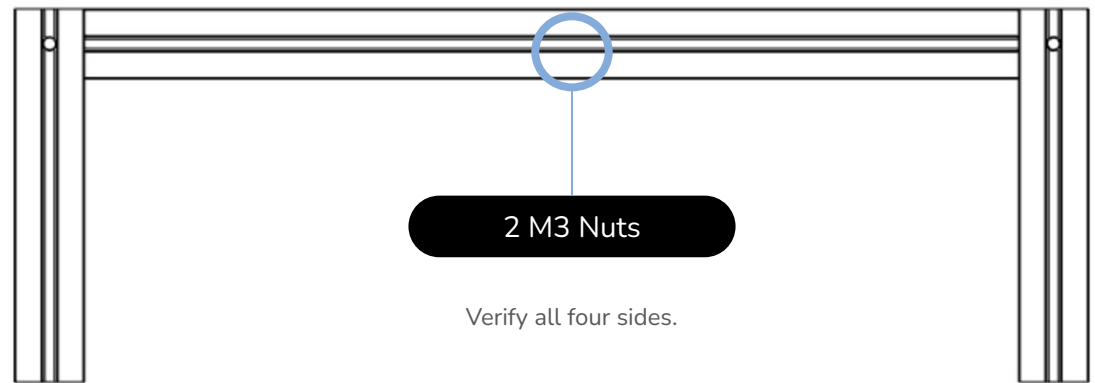

EXTRUSION TOPHAT

WWW.VORONDESIGN.COM

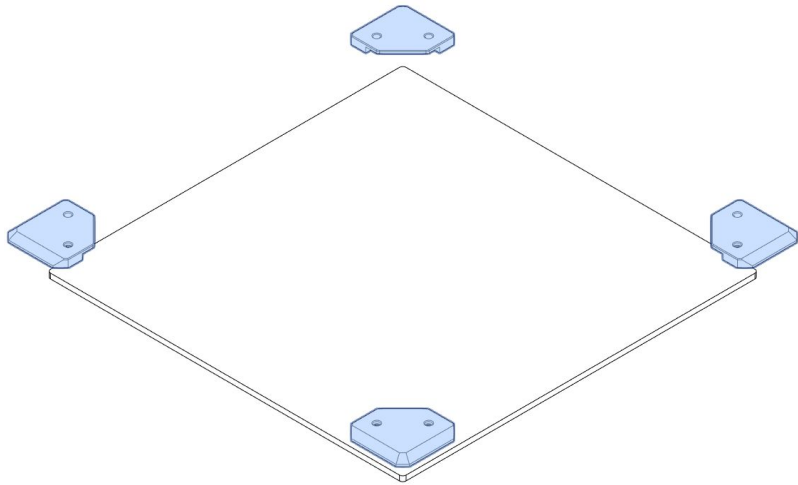
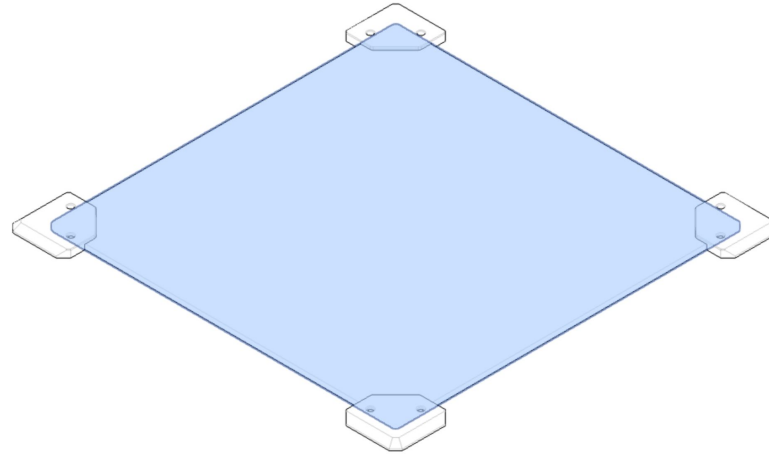

TOP PANEL

Place the 3mm acrylic top panel in place and secure with panel clips. VHB tape is not needed on panel clips.

M3x8 BHCS

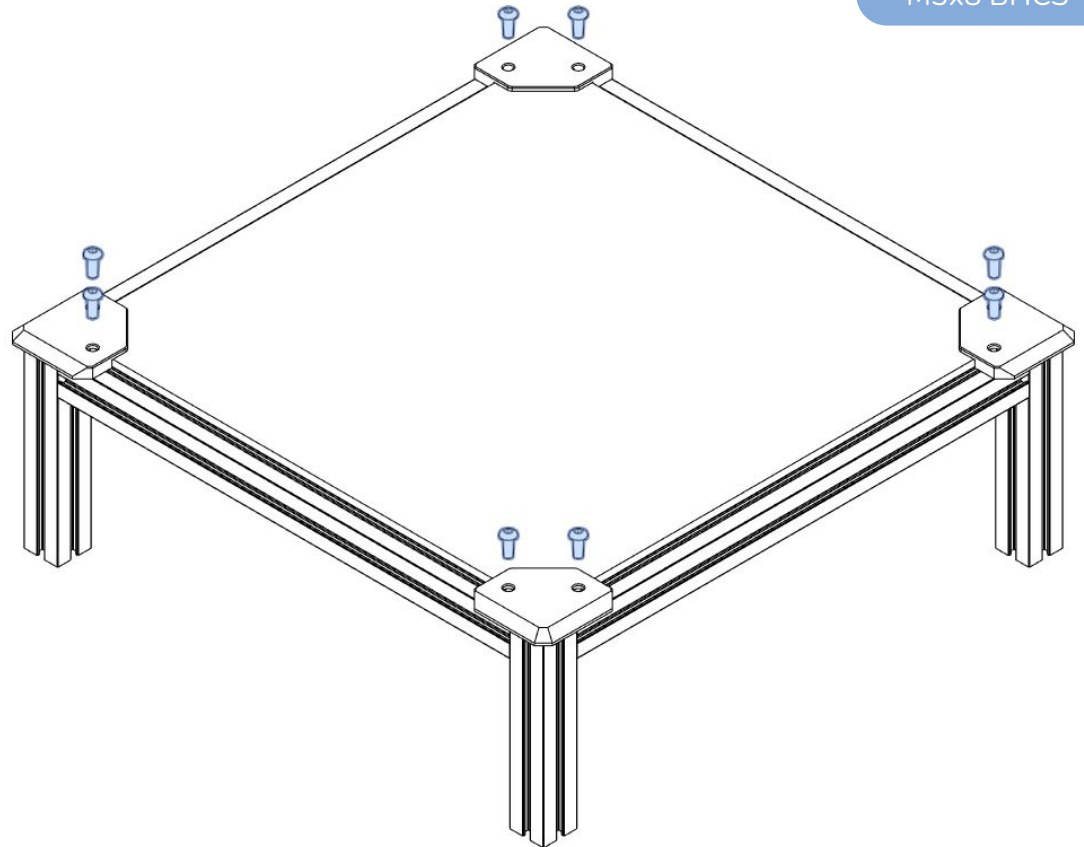

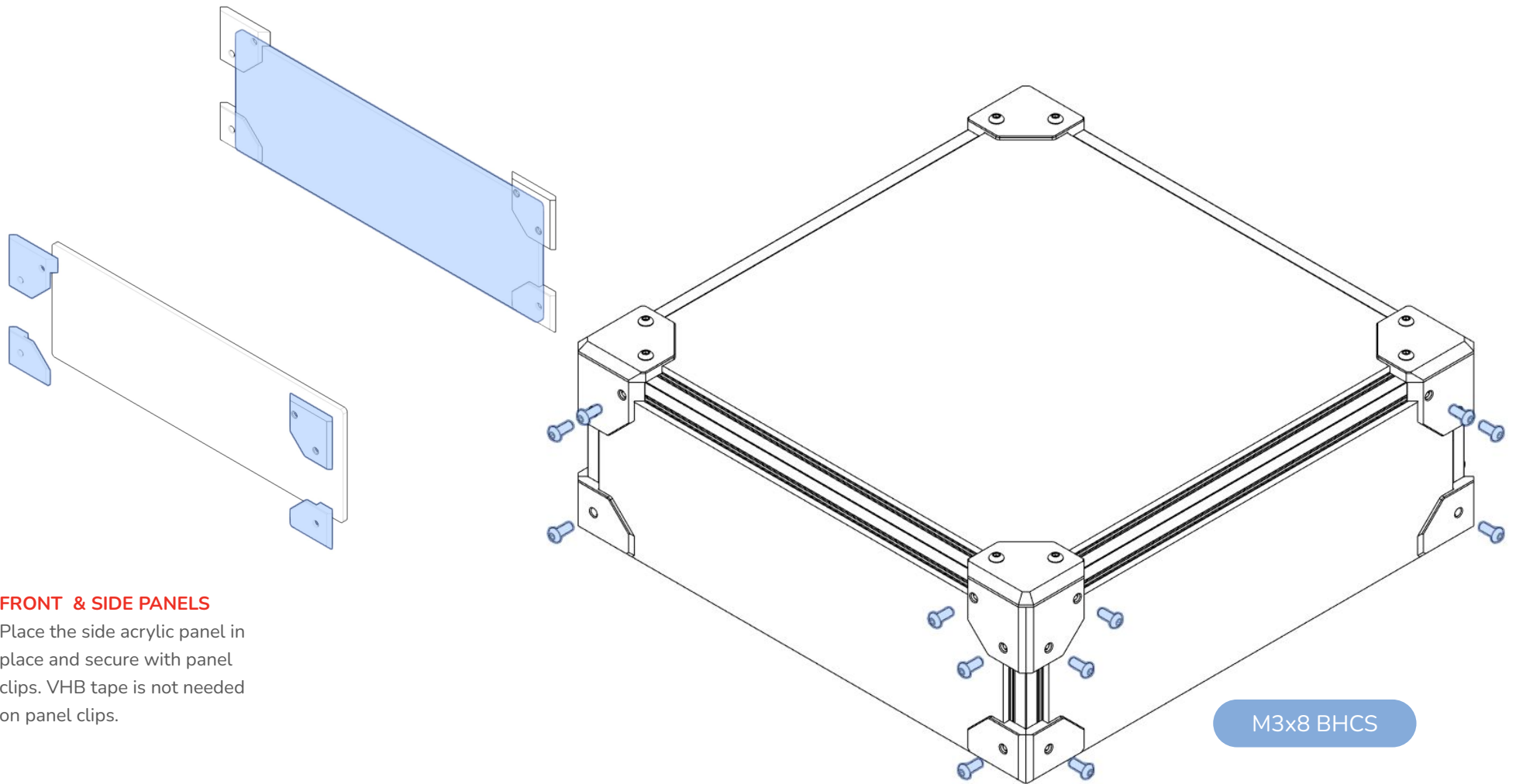

FRONT & SIDE PANELS

Place the side acrylic panel in place and secure with panel clips. VHB tape is not needed on panel clips.

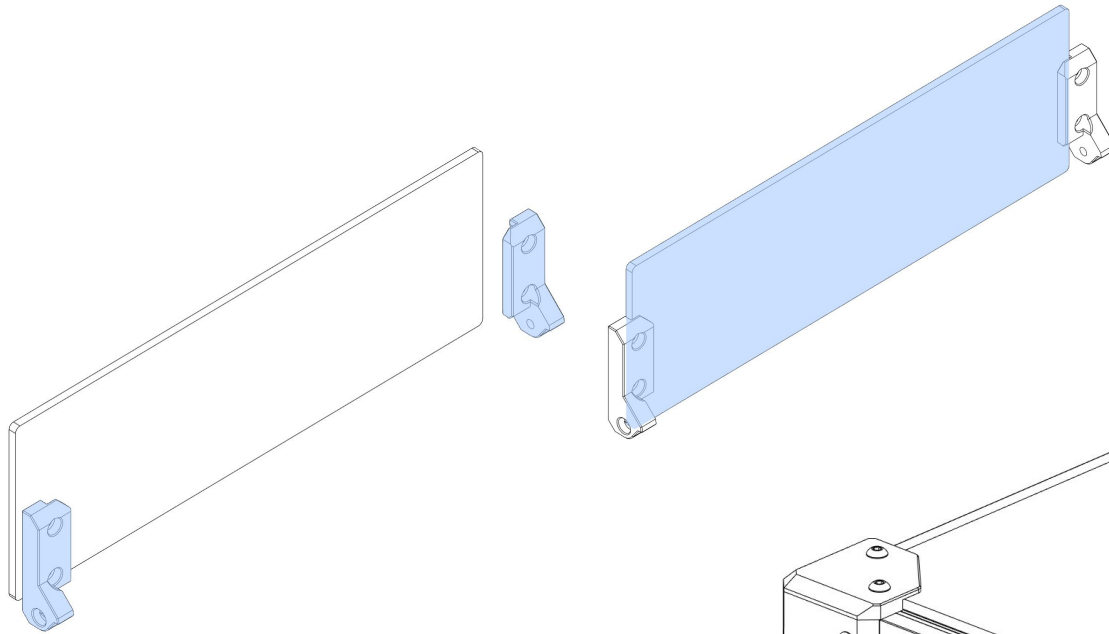

REAR PANEL

Place the rear acrylic panel in place and secure with panel clips. VHB tape is not needed on panel clips.

The rear panels needs to be opposite the side that has the screws protruding 5mm from the extrusions.

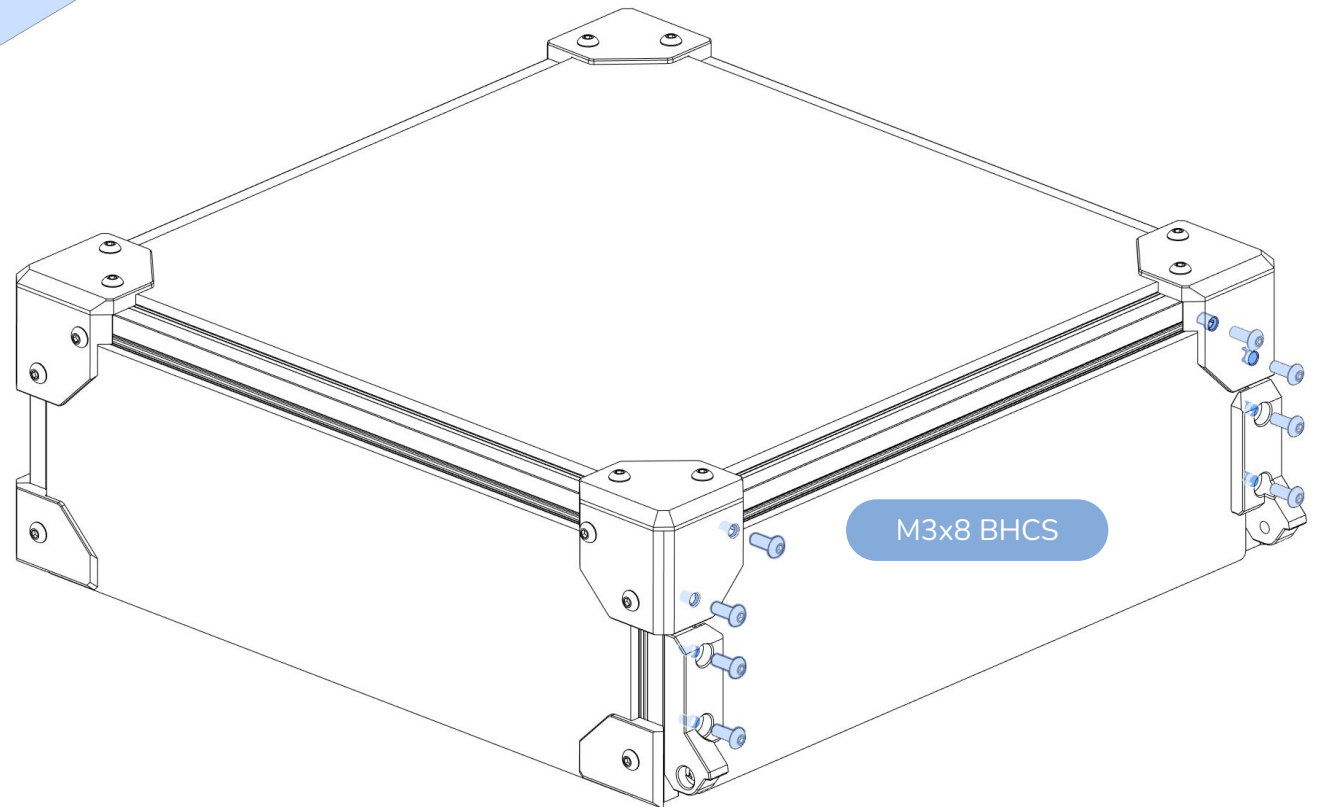

TOPHAT HINGES

The hinges can be loosely attached at this step. We will finalize their vertical position on the next page so that they align perfectly with the lower hinge pieces.

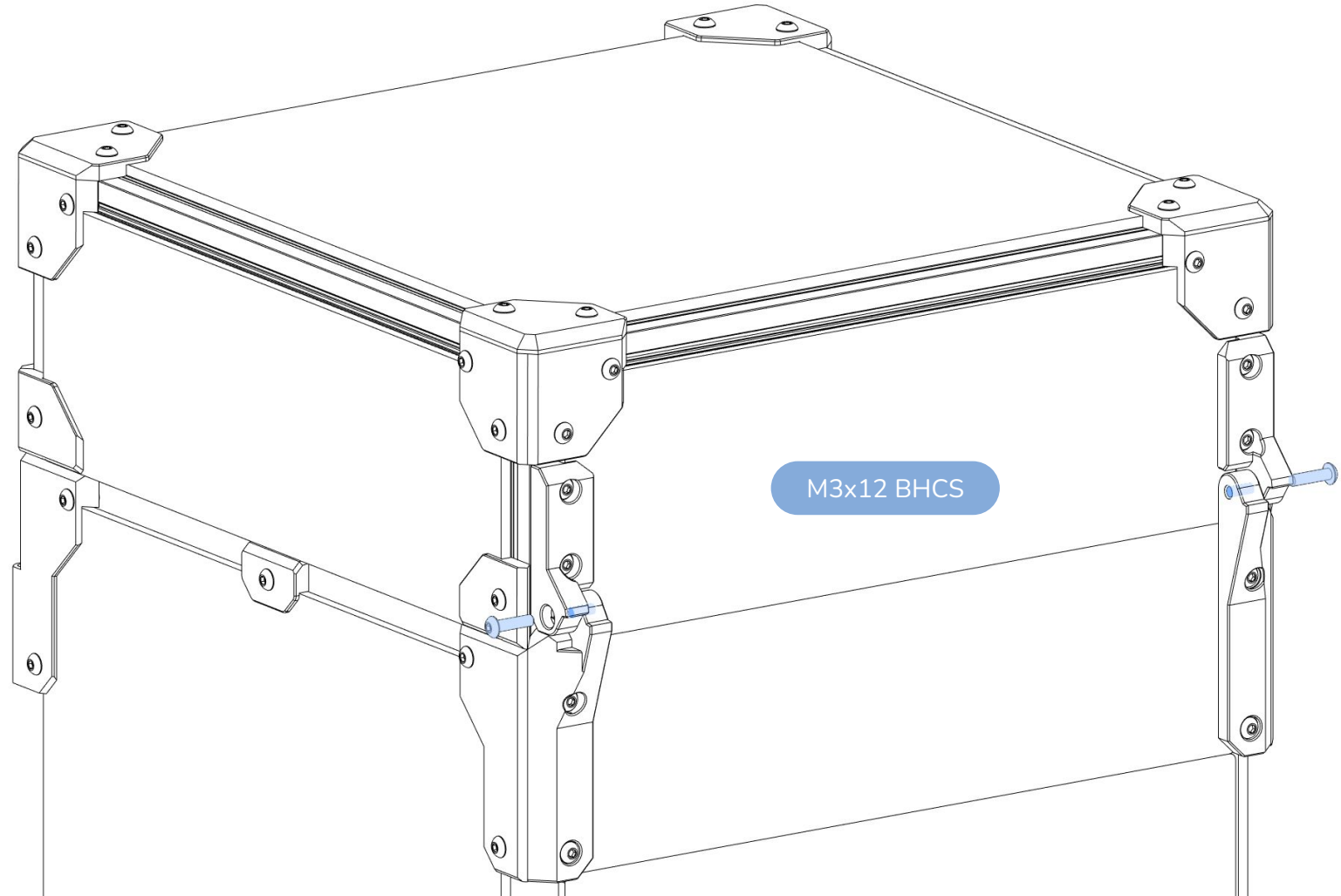

ATTACH TOPHAT

Attach Top Hinge to Bottom Hinge with M3x12 BHCS.

Carefully screw these bolts into the plastic part.

Be careful threading screws directly into plastic! If you over-tighten the screws, then you may strip out the plastic.

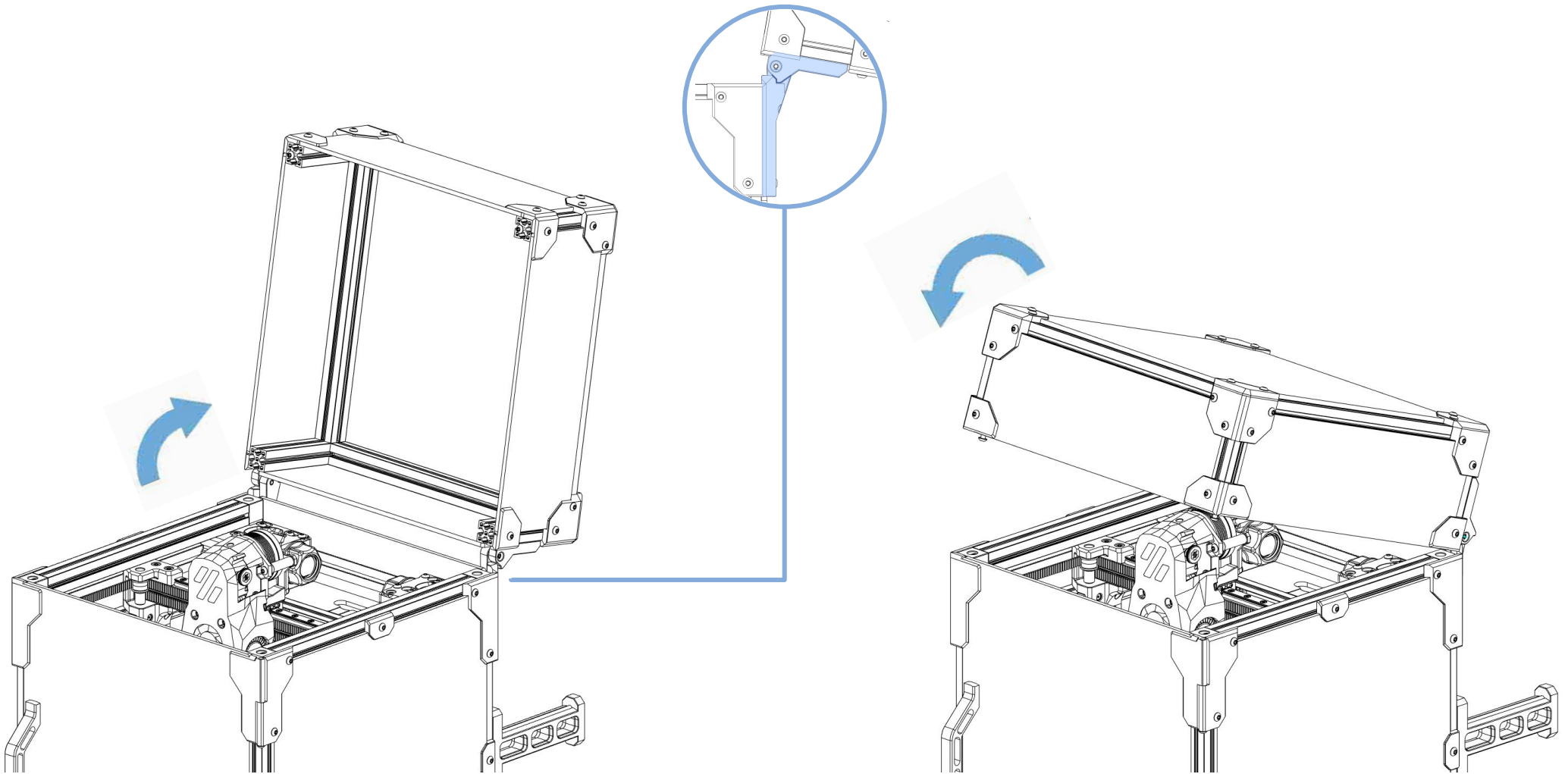

TOPHAT MOVEMENT

Check the range of the tophat to ensure it rotates freely and can open and close smoothly. Make sure the cam locks are in the open position so the M3 bolt heads can seat into the locks.

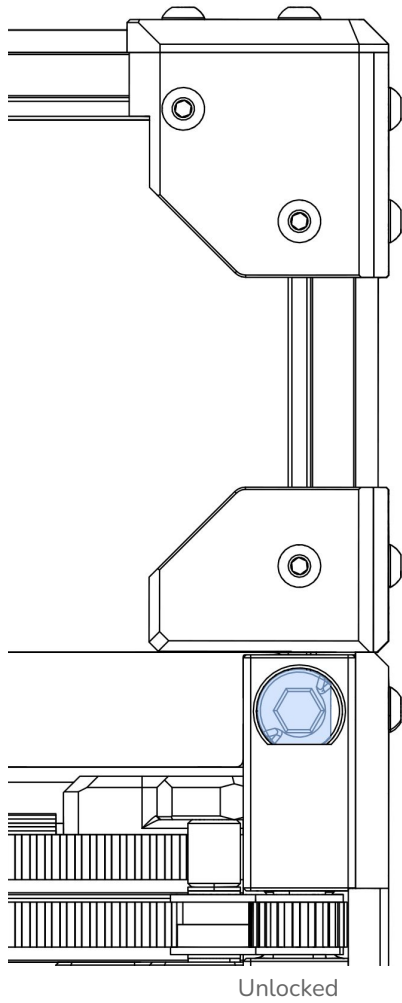

FORGOT YOUR KEYS?

We've added a handy feature to the pulley jig that works nicely as a cam lock key. A 5mm allen key works as well.

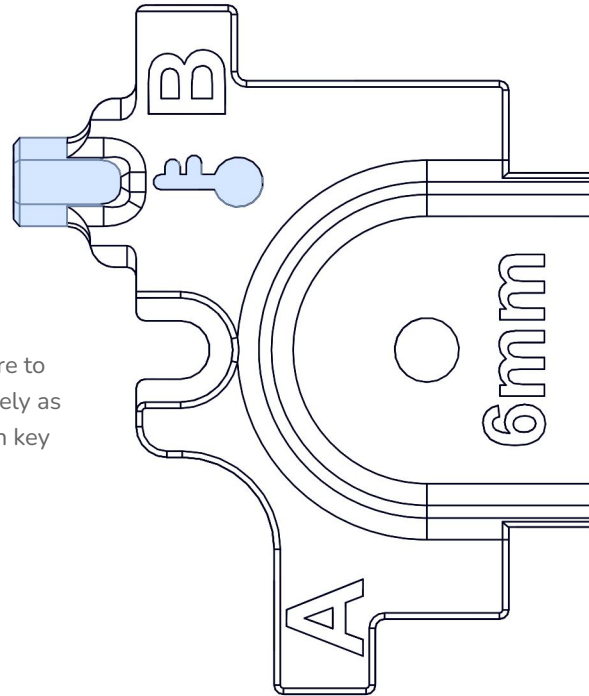

TOPHAT LOCKING

Rotating the cam locks 90 degrees clockwise will lock the tophat in place.

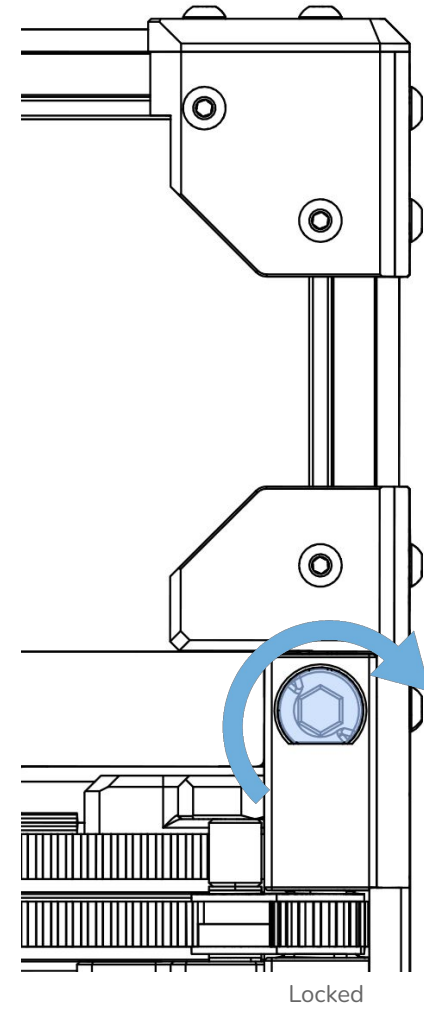

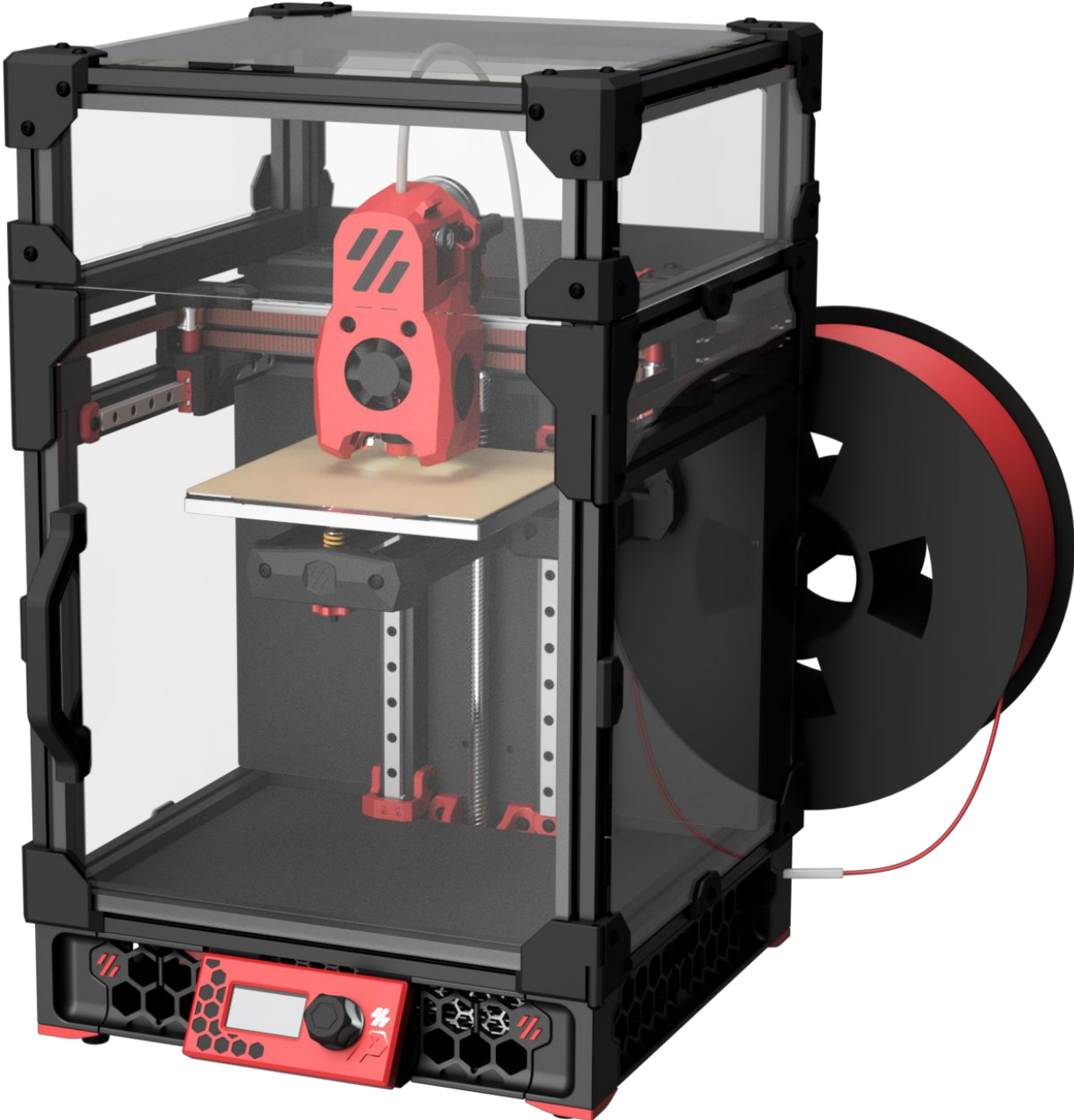

Audio Book Coming SOON™!

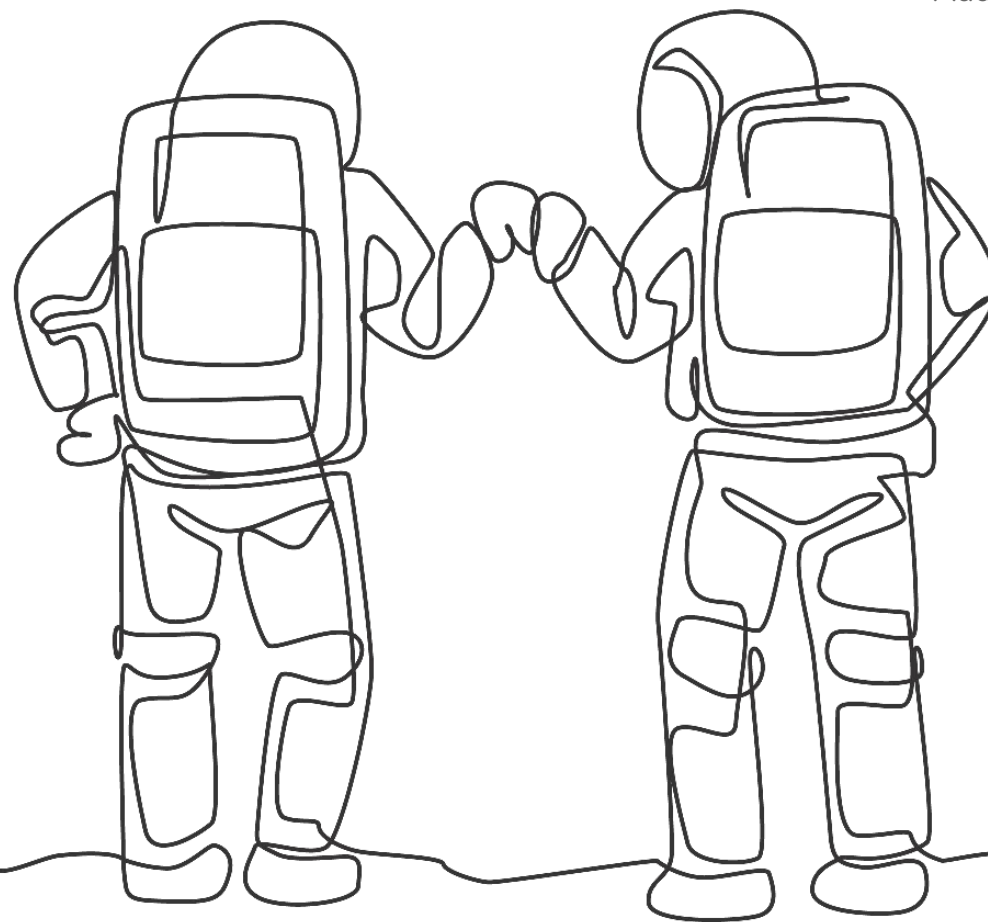

ASSEMBLY COMPLETE! NOW WHAT?

This manual is designed to be a reference manual for the build process of a Voron Zero printer. Additional details about the rest of the build and background on advanced topics can be found on our documentation page linked below. The software setup and other initial setup steps with your new printer can also be found on our documentation page. We recommend starting here: <https://voron.link/cjq72t9>.

HOW TO GET HELP

If you need assistance with your build, we're here to help. Head on over to our Discord group and post your questions. This is our primary medium to help VORON Users and we have a great community that can help you out if you get stuck.



<https://discord.gg/voron>



<https://forum.vorondesign.com>

REPORTING AN ISSUE

Should you find an issue in the documentation or have a suggestion for an improvement, please consider opening an issue on GitHub (<https://github.com/VoronDesign/Voron-0/issues>). When raising an issue please include the relevant page numbers and a short description; annotated screenshots are also very welcome. We periodically update the manual based on the feedback we get.



<https://github.com/VoronDesign>



<https://docs.vorondesign.com/>



Special Thanks to: Hartk, Maverick, Le0n, Kyleisah, Rhastlyn, and the rest of the Voron community.

-Nemgrea

WEBSITE
www.vorondesign.com

GITHUB
<https://github.com/VoronDesign>

DISCORD
<https://discord.gg/voron>





 VORON ZERO